

HAYRITE

BALE HANDLING SYSTEMS

- Stronger Construction
- Better Engineering
- Smoother, More Dependable Operation
- Wider Choice of Accessories
- Lower Cost

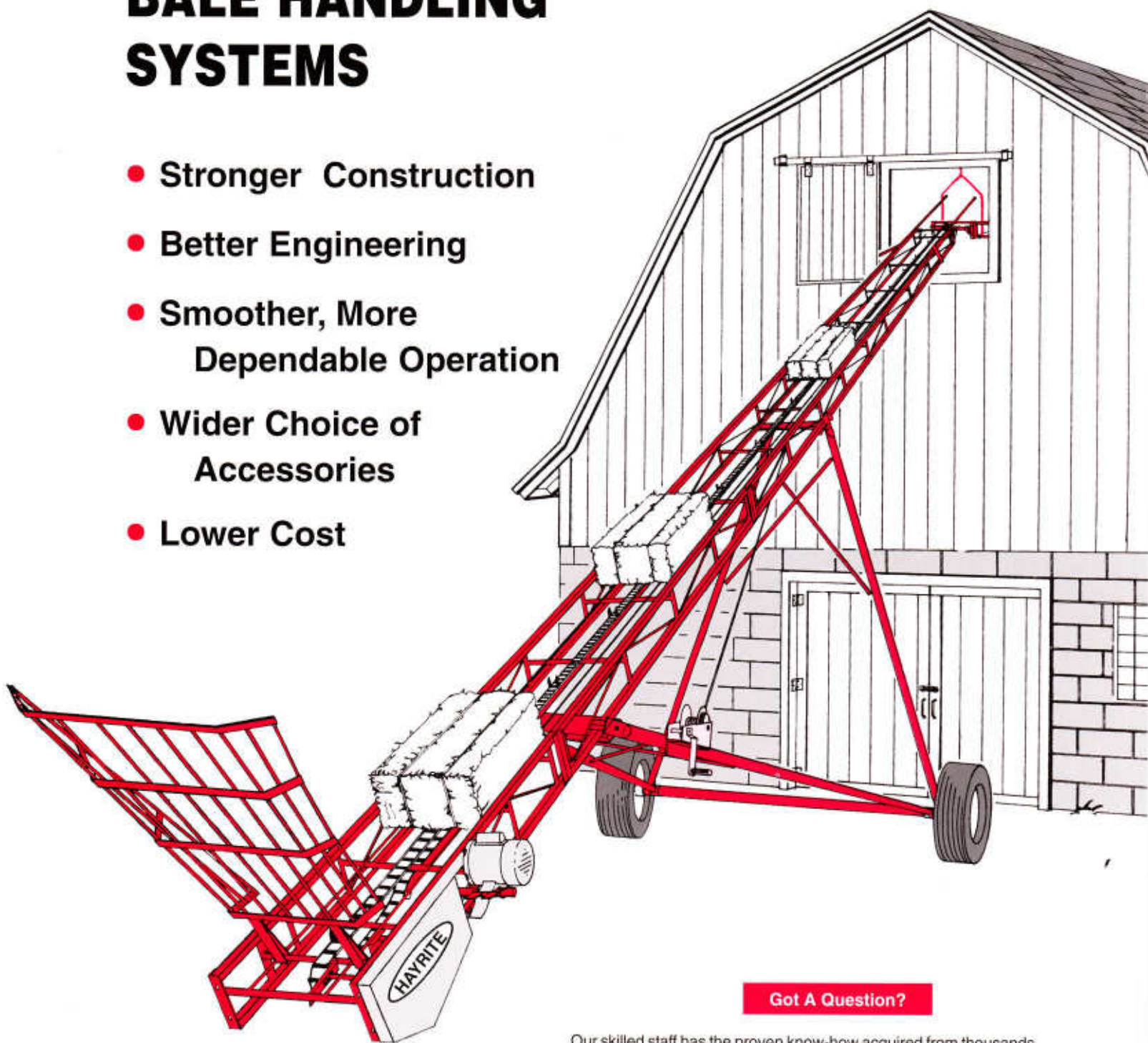

Got A Question?

Our skilled staff has the proven know-how acquired from thousands of barn installations. We can draw on our many years of experience to answer your technical questions. We'll help you select the most effective, most economical bale handling system.

Product illustrations are for illustrative purposes only. For your safety, please read the Owner's and Operator's Manual completely before using any equipment.

HAYRITE Foot for Foot, Pound for Pound...

Begin with the basic elevator... and custom make a bale handling system to fit your specific needs... all at a surprisingly low cost!

Basic elevator includes a drive unit, plus an end section with sprocket and chain tightener. Basic elevator can be easily lengthened by adding interchangeable long and short center extensions. A complete line of accessories are available to make storing bales a smooth, quick and simple one-man operation.

COMPONENT LENGTHS

Model Description	Basic Unit	Extensions
Extra Heavy-Duty	18'	12' or 6'
Standard	16'	8' or 4'

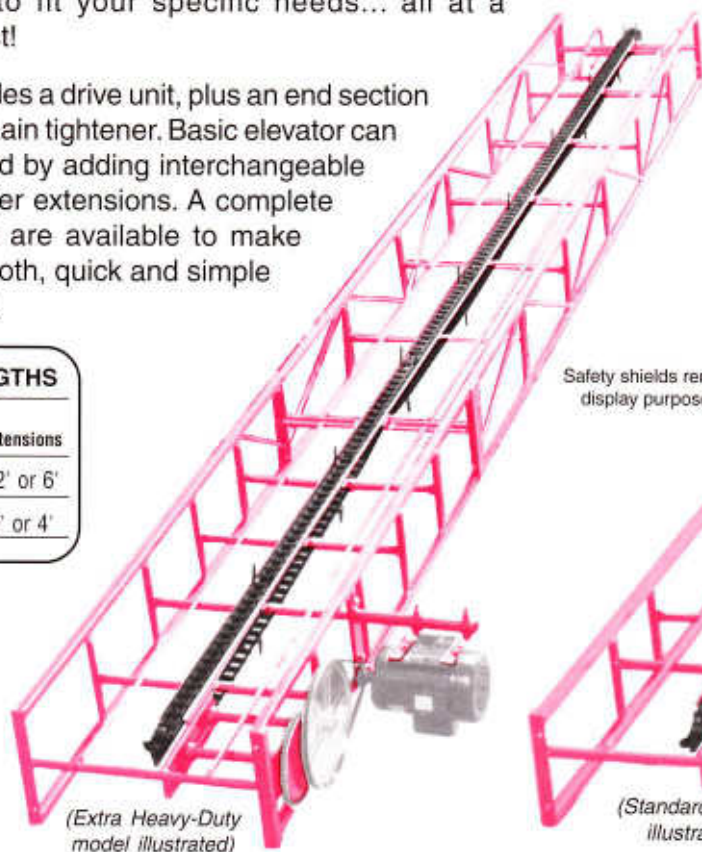

Safety shields removed for display purposes only.

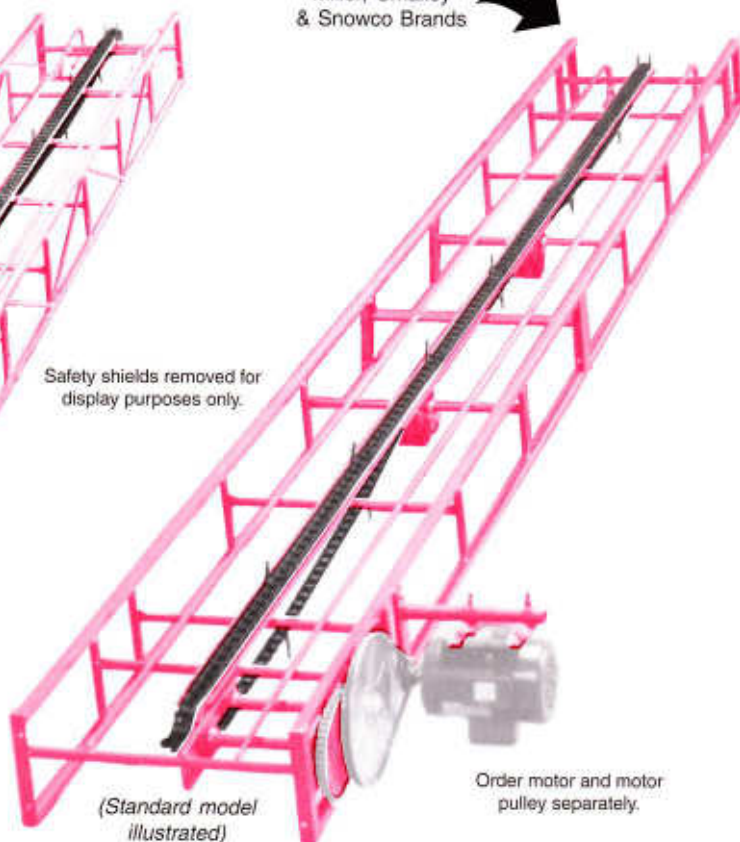

Bolts up to Miller, Smalley & Snowco Brands



Order motor and motor pulley separately.

Hayrite Gives You Stronger Construction — Better Engineering!

- **High-strength 1" square tubing** — 70% more flexural strength than comparable round tubing.
- **Heavier design** — use as inclined conveyor, mow conveyor or both
- **Thicker-walled 15 ga. steel construction.**
- 'Bridge truss' **side reinforcements along full length** of elevator prevent sagging, bowing, twisting, and bending. Inclined elevators are self-supporting up to 54'.
- **Higher side rails** allow bales to sit down deep in elevator (preventing irregular-shaped bales from tumbling out).
- Extra heavy-duty No. 62 conveyor chain equipped with **raised links every 24"** for more positive movement.
- Heavy-duty No. 55 conveyor chain equipped with **raised links every 24"** for more positive movement.
- **Bronze pillow block bearings** on drive unit — self aligning with **grease zerks.**
- Full 1" **solid head and jack shafts.**
- Permanently-lubricated, sealed **ball-bearing** idler sprockets.
- Greaseable, **bronze-bushing** idler sprockets.
- Stronger **No. 40 roller chain final drive.**
- All electrically wire-welded construction — **welds go all the way around seams** for added strength.
- Sturdy, **universal motor mount** for electric motors is **adjustable** for leveling, belt take-up and "stop and go" operation. Mount is quickly detachable for inside storage of motor (drive belt included).
- **Powder-coated red finish...** for longer life.

Model Description
Extra Heavy-Duty Standard

✓ ✓

✓ ✓

✓

✓

✓

✓

✓ ✓

✓ ✓

✓

✓ ✓

✓ ✓

✓ ✓

✓ ✓

✓ ✓

✓ ✓

✓ ✓

✓ ✓

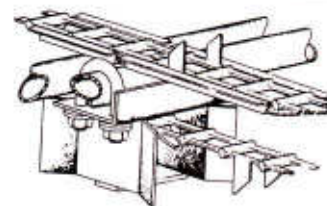

Exclusive Return-Chain Guide Design

Heavier, **more dependable** return-chain guides. **Specially-engineered** and field proven to eliminate mechanical headaches common with return guides on other brand elevators — prevents sagging, catching, twisting and stretching — increases chain life.



Special Conveyor-Chain Track — Stronger Connecting Joints

Conveyor-chain track has **exclusive double-formed-bend design** for extra rigidity. Prevents the sagging and bending common with other single-formed-bend tracks. **Heavier, angle-iron connecting joints (1 1/4"x1 1/4")** and hardened bolts prevent stretching — joints are quicker and easier to connect. Strongest structural design available.

More Strength, More Quality, More Value for Your Dollar!

Select from a wider choice of accessories for faster, easier and more efficient one-man bale handling.

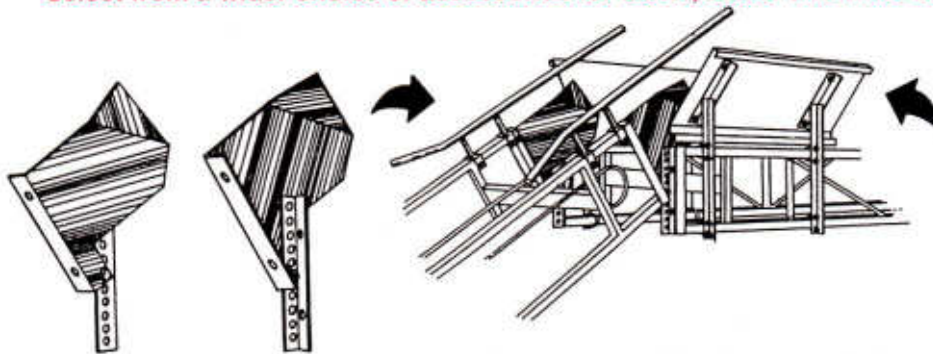

Connector plates: Connects incline elevator to horizontal mow conveyor. Prevents bales from turning and tumbling out when transferring.

Above drawing illustrates incline elevator assembled to horizontal conveyor, using Bale Guides (model HST-7A), Connector Plates (model HST-17A or 18A) and Bale Arrangers (model HST-16A).

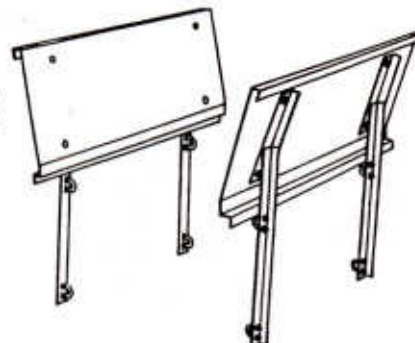

Bale arrangers: Directs irregular shaped bales into horizontal conveyor. Made of heavy galvanized steel.



Bale chute (grate-type, 6' length)

Hinges to elevator — tips back against wagon or truck for easy unloading. Long-taper design automatically lines up each bale to prevent them from tipping or turning while being conveyed up elevator. Grate-type construction permits loose material to fall through for smoother operation.

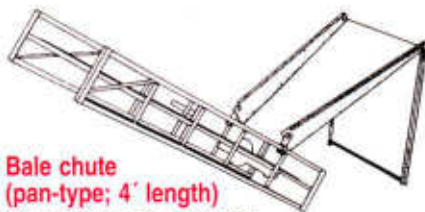

Bale chute (pan-type, 4' length)

Hinges to elevator — rests on its own stand or tips back against wagon or truck for easy unloading. Made of heavy, galvanized steel. Short-taper design automatically lines up each bale to prevent them from tipping or turning while being conveyed up elevator.

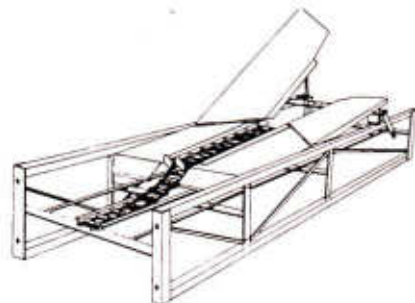

Bale kickoff Sturdy, tapered design provides for fast, smooth, accurate unloading to either right or left from any point along conveyor. Pull control rope (rope not included), from mow floor to change direction of unloading or to slide kickoff to any position along full length of conveyor. Bales cannot be conveyed over kickoff and onward toward end of conveyor.

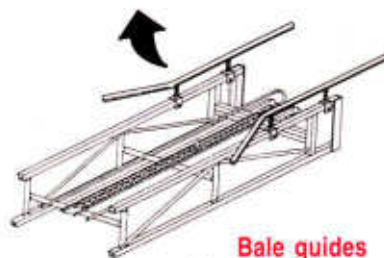

Bale guides

Keeps bale twine from catching and breaking when bales are discharging from a steeply inclined elevator. Prevents bales from tipping and turning and then tumbling out when transferring from an inclined elevator to mow conveyor. Pair of sturdy steel tubes clamp onto sides of inclined elevator on top end.



Bale rails

Rails increase height of elevator sides to prevent irregular-shaped bales from tumbling out. Rigid 12' long steel rails clamp onto sides of inclined elevator.

Mow hangers

Makes it simple and easy to install conveyor from hayrack, rafters, or roof. Sturdy tubular steel hangers are extra wide to prevent bales from snagging. Recommended at ends and every 12' of conveyor length for proper support.



(No. HST-40T Transport illustrated)

Transports Engineered for better balance and greater strength — now you can move your elevator with ease to exactly where you want it. Rugged, oversize 2" x 3" x 1/8" steel tubing transports are extra heavy for more strength. Wheels are set far apart for increased stability. Equipped with 15" four-bolt, ag-type wheel rims (less rubber tires) mounted on regreaseable, tapered roller bearings (max. speed — 20 mph). Transport can be quickly raised from towing position up to 45°. Sturdy, easy-to-operate hand winch features double-disc, automatic brake system for positive load control. Winch is zinc plated to resist rust.

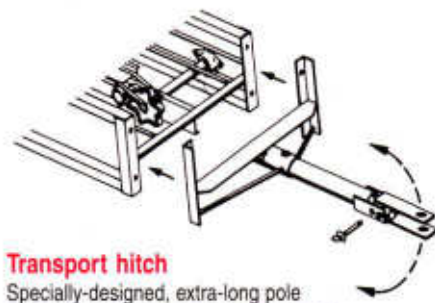

Transport hitch

Specially-designed, extra-long pole to prevent elevator from binding against tractor or truck bumper during short turns — pole unpins for easy removal. Pin can be removed from rigid clevis to permit swiveling — prevents tractor or truck hitch pin from binding when elevator is raised.

LAYOUT GUIDE

HAYRITE BALE HANDLING SYSTEMS

For each Reference No. ① below, refer to related Reference No. ② on layout illustrations below.

Reference No.	Component Description and (Model No.)
①	Transport Hitch (HST-10A or HST-15A)
②	Bale Chute (HST-5A or HST-12A)
③	Drive Unit and Electric Motor Location
④	Transport (HST-10T, HST-20T or HST-40T)

Reference No.	Component Description and (Model No.)
⑤	Bale Guides (HST-7A)
⑥	Connector Plates (HST-17A or HST-18A)
⑦	Bale Arrangers (HST-16A)
⑩	Mow Hanger Chain Kit (HST-2A)
⑪	Automatic Bale Kick-off (HST-1A or HST-13A)

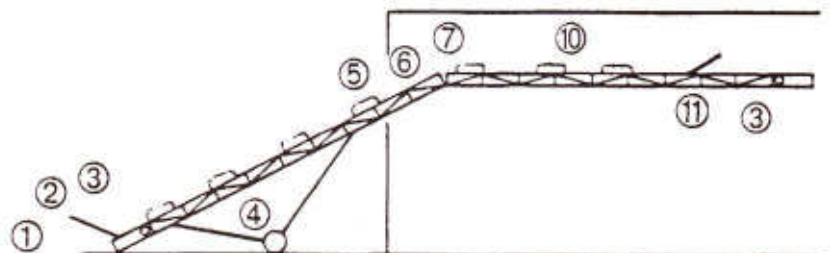
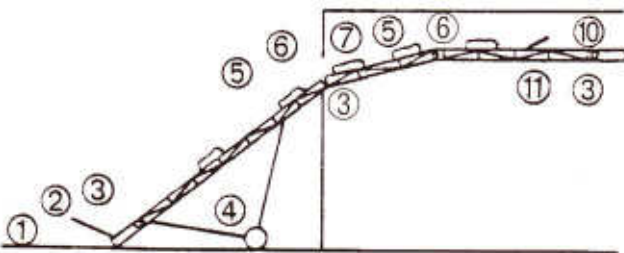
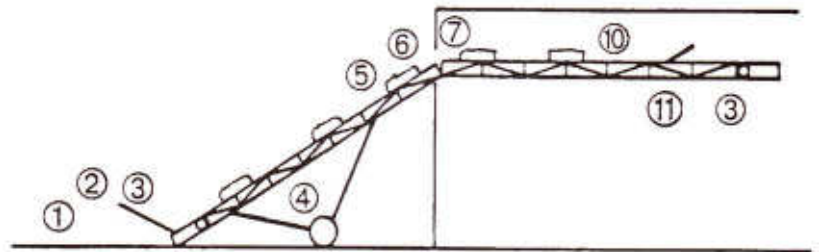
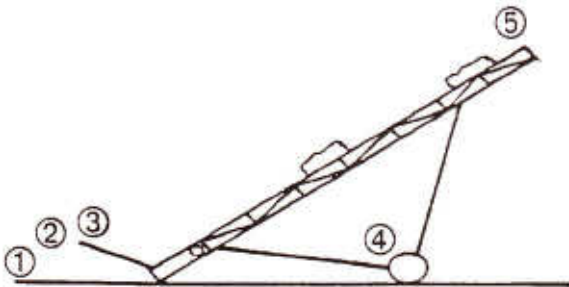

LAYOUT GUIDE

HAYRITE BALE HANDLING SYSTEMS

For each Reference No. # below, refer to related Reference No. # on layout illustrations below.

- | Reference No. | Component Description and (Model No.) |
|---------------|-----------------------------------------|
| ① | Transport Hitch (HST-10A or HST-15A) |
| ② | Bale Chute (HST-5A or HST-12A) |
| ③ | Drive Unit and Electric Motor Location |
| ④ | Transport (HST-10T, HST-20T or HST-40T) |

- | Reference No. | Component Description and (Model No.) |
|---------------|---------------------------------------------|
| ⑤ | Bale Guides (HST-7A) |
| ⑥ | Connector Plates (HST-17A or HST-18A) |
| ⑦ | Bale Arrangers (HST-16A) |
| ⑩ | Mow Hanger Chain Kit (HST-2A) |
| ⑪ | Automatic Bale Kick-off (HST-1A or HST-13A) |

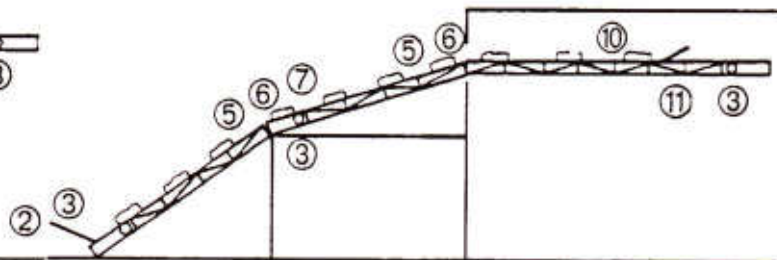
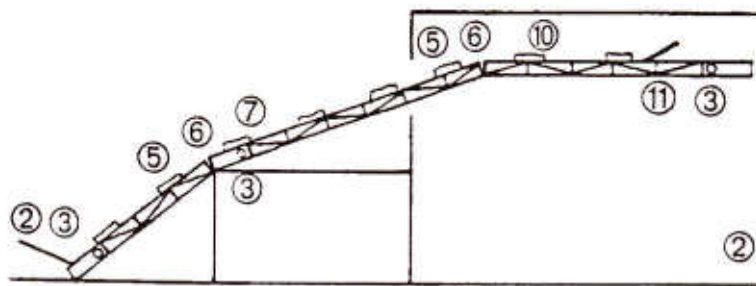
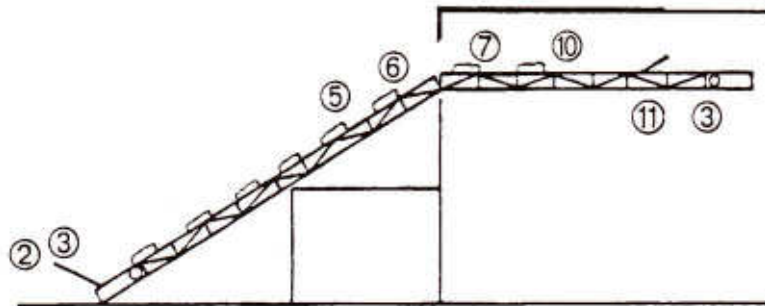
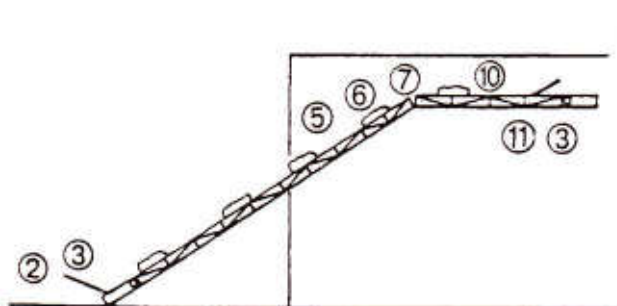

Operating Heights & General Dimensions

Safety Cable Removed for Display Purposes Only

TOWING ANGLE

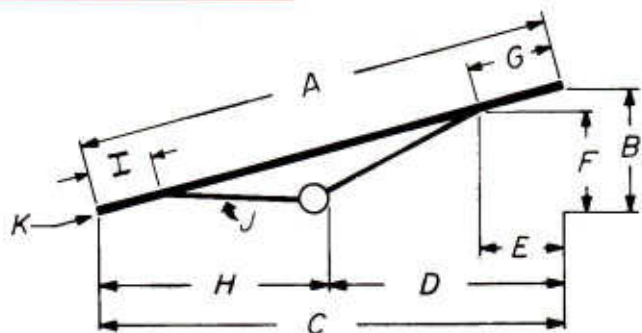

30° ANGLE

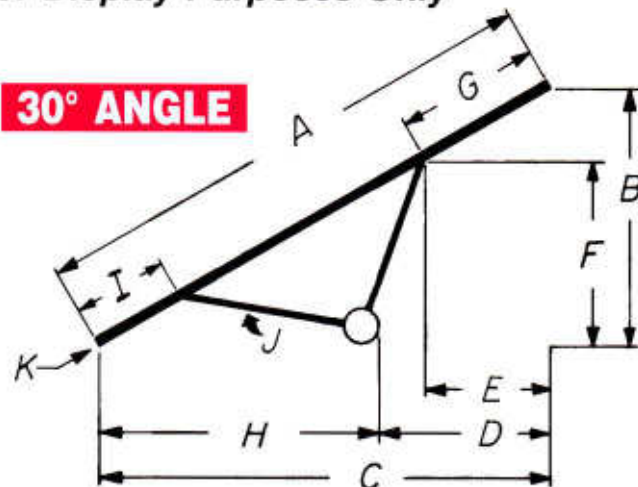

35° ANGLE

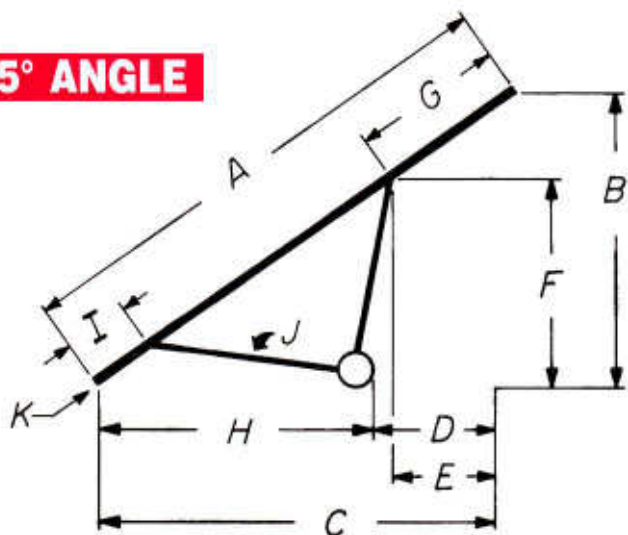

40° ANGLE

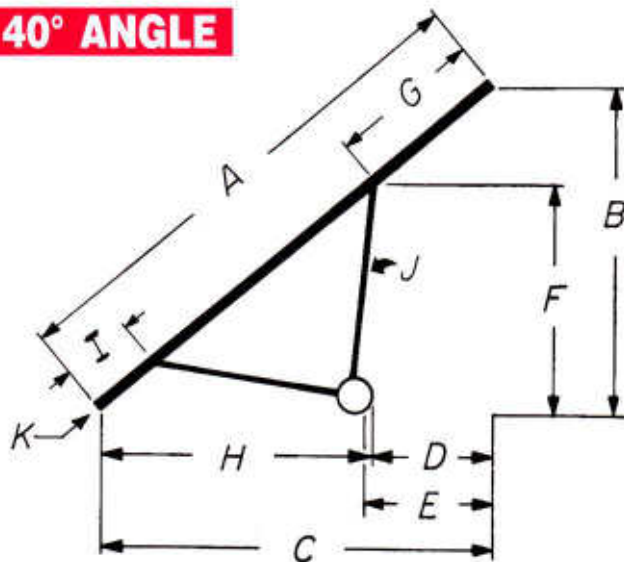

45° ANGLE

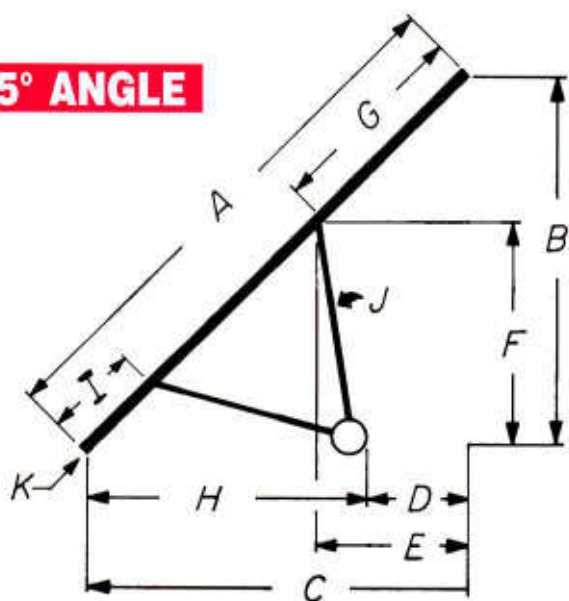

TRANSPORT AXLE WIDTH

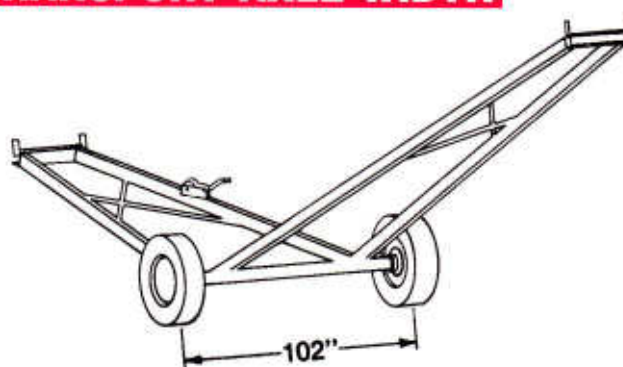

(From center of tire to center of tire - outside width will vary depending on tire width)

	Elevator Length	Discharge Height	Reach	Wheel to Wall	Eave Clearance	Free Clearance	Elevator Overhang	Wheel to Elevator End	Elevator End to Transport Mount	Leg	Weight at Hitch, including Motor & Bale Chute
	A	B	C	D	E	F	G	H	I	J	K
TOWING ANGLE — Model HST-10T Transport											
20°	7' 7"	18' 11"	6' 10"	0' 10"	6' 3"	1' 5"	12' 1"	2' 7"	9' 0"		161 lbs.
24°	9' 1"	22' 8"	10' 7"	4' 7"	6' 3"	5' 4"	12' 1"	2' 7"	9' 0"		124 lbs.
28°	10' 4"	26' 6"	14' 5"	8' 5"	6' 3"	9' 5"	12' 1"	2' 7"	9' 0"		81 lbs.
30°	10' 5"	28' 6"	15' 6"	9' 4"	6' 3"	10' 7"	13' 0"	3' 6"	9' 0"		70 lbs.
32°	10' 4"	30' 7"	16' 11"	10' 9"	6' 1"	11' 9"	13' 9"	4' 3"	9' 0"		71 lbs.
TOWING ANGLE — Model HST-20T Transport											
36°	10' 3"	34' 11"	16' 6"	2' 7"	8' 1"	4' 10"	18' 5"	2' 7"	15' 0"		140 lbs.
40°	10' 10"	38' 10"	19' 8"	6' 3"	8' 1"	8' 3"	19' 2"	3' 4"	15' 0"		116 lbs.
42°	11' 3"	40' 9"	21' 4"	8' 11"	7' 11"	9' 9"	19' 5"	3' 7"	15' 0"		97 lbs.
44°	11' 2"	42' 10"	22' 5"	9' 10"	7' 8"	11' 0"	20' 6"	4' 8"	15' 0"		98 lbs.
48°	11' 2"	47' 1"	24' 11"	12' 1"	6' 10"	13' 0"	22' 3"	6' 5"	15' 0"		85 lbs.
TOWING ANGLE — Model HST-40T Transport											
54°	11' 1"	53' 2"	26' 2"	8' 2"	7' 11"	9' 0"	27' 0"	6' 0"	20' 0"		135 lbs.
60°	11' 7"	59' 1"	31' 1"	13' 1"	8' 1"	14' 3"	28' 0"	7' 0"	20' 0"		81 lbs.
30° ANGLE — Model HST-10T Transport											
20°	10' 0"	17' 4"	5' 5"	2' 2"	8' 9"	2' 6"	11' 11"	2' 7"	9' 0"		184 lbs.
24°	12' 0"	20' 9"	8' 11"	5' 8"	8' 9"	6' 6"	11' 11"	2' 7"	9' 0"		158 lbs.
28°	14' 0"	24' 3"	12' 4"	9' 2"	8' 9"	10' 6"	11' 11"	2' 7"	9' 0"		120 lbs.
30°	15' 0"	26' 0"	13' 4"	10' 6"	8' 11"	12' 1"	12' 8"	3' 6"	9' 0"		115 lbs.
32°	16' 0"	27' 9"	14' 5"	11' 11"	9' 1"	13' 10"	13' 3"	4' 3"	9' 0"		112 lbs.
30° ANGLE — Model HST-20T Transport											
36°	18' 0"	31' 2"	13' 0"	6' 7"	14' 3"	7' 7"	18' 2"	2' 7"	15' 0"		205 lbs.
40°	20' 0"	34' 8"	15' 10"	9' 8"	14' 5"	11' 2"	18' 9"	3' 4"	15' 0"		178 lbs.
42°	21' 0"	36' 4"	17' 4"	11' 4"	14' 6"	13' 1"	19' 0"	3' 7"	15' 0"		170 lbs.
44°	22' 0"	38' 1"	18' 3"	12' 8"	14' 8"	14' 7"	19' 11"	4' 8"	15' 0"		167 lbs.
48°	24' 0"	41' 7"	20' 3"	15' 6"	15' 1"	17' 10"	21' 4"	6' 5"	15' 0"		160 lbs.
30° ANGLE — Model HST-40T Transport											
54°	27' 0"	46' 9"	20' 7"	12' 11"	19' 7"	14' 11"	26' 2"	6' 0"	20' 0"		225 lbs.
60°	30' 0"	52' 0"	25' 0"	17' 10"	19' 8"	20' 8"	27' 0"	7' 0"	20' 0"		190 lbs.
35° ANGLE — Model HST-10T Transport											
20°	11' 6"	16' 5"	4' 7"	3' 0"	9' 5"	3' 7"	11' 9"	2' 7"	9' 0"		199 lbs.
24°	13' 9"	19' 8"	7' 11"	6' 3"	9' 5"	7' 7"	11' 9"	2' 7"	9' 0"		180 lbs.
28°	16' 1"	22' 11"	11' 2"	9' 6"	9' 5"	11' 7"	11' 9"	2' 7"	9' 0"		141 lbs.
30°	17' 3"	24' 7"	12' 1"	10' 11"	9' 7"	13' 4"	12' 6"	3' 6"	9' 0"		137 lbs.
32°	18' 4"	26' 3"	13' 2"	12' 5"	9' 8"	15' 2"	13' 0"	4' 3"	9' 0"		132 lbs.
35° ANGLE — Model HST-20T Transport											
36°	20' 8"	29' 6"	11' 6"	7' 7"	15' 4"	9' 3"	18' 0"	2' 7"	15' 0"		240 lbs.
40°	22' 11"	32' 9"	14' 2"	10' 8"	15' 6"	13' 0"	18' 7"	3' 4"	15' 0"		215 lbs.
42°	24' 1"	34' 5"	15' 7"	12' 3"	15' 6"	14' 11"	18' 10"	3' 7"	15' 0"		208 lbs.
44°	25' 3"	36' 0"	16' 5"	13' 7"	15' 9"	16' 7"	19' 8"	4' 8"	15' 0"		200 lbs.
48°	27' 6"	39' 4"	18' 4"	16' 7"	15' 11"	20' 3"	20' 11"	6' 5"	15' 0"		188 lbs.
35° ANGLE — Model HST-40T Transport											
54°	31' 0"	44' 3"	18' 4"	14' 8"	20' 9"	17' 9"	25' 10"	6' 0"	20' 0"		272 lbs.
60°	34' 5"	49' 2"	22' 7"	19' 4"	20' 11"	23' 7"	26' 7"	7' 0"	20' 0"		230 lbs.
40° ANGLE — Model HST-10T Transport											
20°	12' 10"	15' 4"	3' 8"	3' 8"	9' 9"	4' 10"	11' 8"	2' 7"	9' 0"		216 lbs.
24°	15' 5"	18' 5"	6' 9"	6' 9"	9' 9"	8' 10"	11' 8"	2' 7"	9' 0"		200 lbs.
28°	18' 0"	21' 5"	9' 10"	9' 10"	9' 9"	12' 10"	11' 8"	2' 7"	9' 0"		162 lbs.
30°	19' 3"	23' 0"	10' 9"	11' 3"	9' 10"	14' 9"	12' 3"	3' 6"	9' 0"		160 lbs.
32°	20' 7"	24' 6"	11' 9"	13' 0"	10' 9"	16' 11"	12' 9"	4' 3"	9' 0"		154 lbs.
40° ANGLE — Model HST-20T Transport											
36°	23' 2"	27' 7"	9' 8"	8' 6"	16' 0"	11' 1"	17' 11"	2' 7"	15' 0"		261 lbs.
40°	25' 9"	30' 8"	12' 3"	11' 6"	16' 1"	15' 0"	18' 5"	3' 4"	15' 0"		248 lbs.
42°	27' 0"	32' 2"	13' 7"	13' 0"	16' 1"	17' 0"	18' 7"	3' 7"	15' 0"		240 lbs.
44°	28' 3"	33' 9"	14' 4"	14' 6"	16' 2"	18' 11"	19' 4"	4' 8"	15' 0"		235 lbs.
48°	30' 10"	36' 9"	16' 3"	17' 11"	17' 3"	23' 4"	20' 6"	6' 5"	15' 0"		226 lbs.
40° ANGLE — Model HST-40T Transport											
54°	34' 9"	41' 4"	15' 10"	16' 0"	21' 4"	20' 10"	25' 6"	6' 0"	20' 0"		312 lbs.
60°	38' 7"	46' 0"	19' 10"	20' 7"	21' 4"	26' 10"	26' 2"	7' 0"	20' 0"		270 lbs.
45° ANGLE — Model HST-10T Transport											
20°	14' 2"	14' 2"	2' 8"	4' 6"	11' 5"	6' 5"	11' 5"	2' 7"	9' 0"		239 lbs.
24°	17' 0"	17' 0"	5' 6"	7' 4"	11' 5"	10' 5"	11' 5"	2' 7"	9' 0"		228 lbs.
28°	19' 10"	19' 10"	8' 4"	10' 2"	11' 5"	14' 5"	11' 5"	2' 7"	9' 0"		197 lbs.
30°	21' 3"	21' 3"	9' 2"	11' 7"	12' 0"	16' 4"	12' 0"	3' 6"	9' 0"		181 lbs.
32°	22' 8"	22' 8"	10' 2"	13' 2"	12' 6"	18' 8"	12' 6"	4' 3"	9' 0"		173 lbs.
45° ANGLE — Model HST-20T Transport											
36°	25' 6"	25' 6"	7' 9"	9' 7"	17' 9"	13' 7"	17' 9"	2' 7"	15' 0"		300 lbs.
40°	28' 3"	28' 3"	10' 1"	12' 5"	18' 3"	17' 7"	18' 3"	3' 4"	15' 0"		287 lbs.
42°	29' 8"	29' 8"	11' 4"	13' 10"	18' 5"	19' 7"	18' 5"	3' 7"	15' 0"		280 lbs.
44°	31' 1"	31' 1"	12' 1"	15' 5"	19' 1"	21' 9"	19' 1"	4' 8"	15' 0"		277 lbs.
48°	33' 11"	33' 11"	13' 11"	18' 6"	20' 1"	26' 2"	20' 1"	6' 5"	15' 0"		270 lbs.
45° ANGLE — Model HST-40T Transport											
54°	38' 2"	38' 2"	13' 1"	17' 5"	25' 1"	25' 7"	25' 1"	6' 0"	20' 0"		352 lbs.
60°	42' 5"	42' 5"	16' 9"	21' 9"	25' 8"	30' 9"	25' 8"	7' 0"	20' 0"		323 lbs.

GOT A QUESTION?

Our skilled staff has the proven know-how acquired from thousands of barn installations. We can draw on our many years of experience to answer your technical questions. We'll help you select the most effective – most economical bale handling system.

HAYRITE

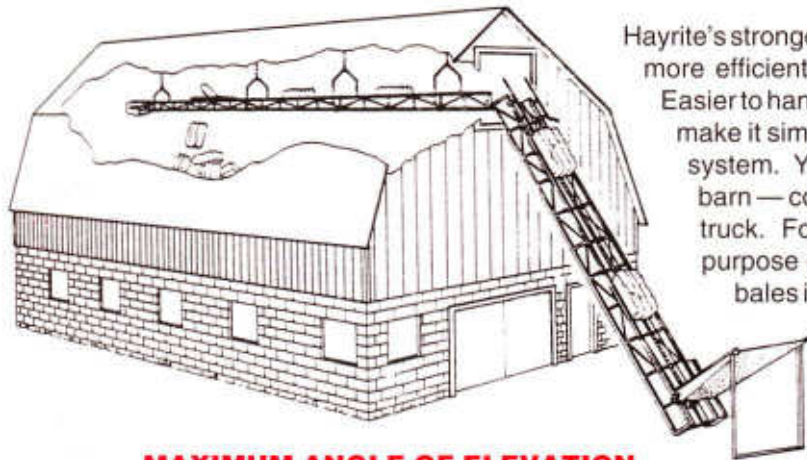

Hayrite's stronger construction and superior engineering gives you smoother, more efficient, trouble-free operation... all at a lower initial investment! Easier to handle, interchangeable sections and a fuller line of accessories make it simple to tailor-make a versatile, yet inexpensive bale handling system. You can elevate bales from your wagon or truck up into your barn — convey and stack bales in the mow — and load or unload your truck. For further savings, you can even use your existing general-purpose elevator with a Hayrite mow conveyor to convey and store bales in the mow. You won't find a better value than Hayrite for fast, easy, dependable, one-man bale handling.

MAXIMUM ANGLE OF ELEVATION FOR VARIOUS BALE LENGTHS

Bale Length	Maximum Elevation Angle
20"	30°
24"	35°
30"	40°
36"	45°

Horsepower Requirements

Bales should be "pulled toward" electric-motor drive end. However, if elevator is mounted on a transport, drive end must remain on ground and "push bales".

Horizontal Conveyor

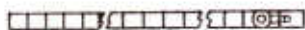

1/2 HP	16' – 28'
3/4 HP	30' – 44'
1 HP	48' – 60'
1-1/2 HP	64' – 90'
2 HP	96' – 120'

Incline Elevator



1/2 HP	16' – 24'
3/4 HP	28' – 40'
1 HP	42' – 44'
1-1/2 HP	48' – 60'

Use 2.8" O.D. Type A motor pulley on horizontal conveyor and incline elevator.
Use a motor rated between 1725 to 1800 RPM.

NOTE: The above chart is only a guide — the size, shape and weight of your bales; angle of elevator; and desired speed may affect your installation. Remember, bales are more effectively pulled than pushed. Less horsepower is required when pulled!

Because T. R. Metal Crafters engineers are constantly improving products, T. R. Metal Crafters reserves the right to change design and/or specifications without notice. The information on this document does not constitute a warranty by T. R. Metal Crafters, Inc.

T. R. Metal Crafters, Inc.

312 East Industrial Drive
PO Box 248
Loyal, Wisconsin 54446
Phone: 1-800-842-5349 or 715-255-8518
FAX: 715-255-9268

MEMBER



Copyright © 2007 by T. R. Metal Crafters, Inc. All rights reserved. This literature, or parts thereof (including charts, tables, and illustrations), may not be reproduced in any form without the prior written permission of the copyright owners.

ELEVATOR LENGTH GUIDE

REACH			ELEVATION		
Elevator Length	Reach	Elevation	Elevator Length	Reach	Elevation
30° Angle			35° Angle		
16'	13' 9"	8' 0"	16'	13' 0"	9' 0"
18'	15' 6"	9' 0"	18'	14' 9"	10' 3"
20'	17' 3"	10' 0"	20'	16' 6"	11' 6"
24'	20' 9"	12' 0"	24'	19' 9"	13' 9"
28'	24' 3"	14' 0"	28'	23' 0"	16' 0"
30'	26' 0"	15' 0"	30'	24' 6"	17' 3"
32'	27' 9"	16' 0"	32'	26' 3"	18' 3"
36'	31' 3"	18' 0"	36'	29' 6"	20' 9"
40'	34' 9"	20' 0"	40'	32' 9"	23' 0"
42'	36' 3"	21' 0"	42'	34' 6"	24' 0"
44'	38' 0"	22' 0"	44'	36' 0"	25' 3"
48'	41' 6"	24' 0"	48'	39' 3"	27' 6"
52'	45' 0"	26' 0"	52'	42' 6"	29' 9"
54'	46' 9"	27' 0"	54'	44' 3"	31' 0"
56'	48' 6"	28' 0"	56'	45' 9"	32' 0"
60'	52' 0"	30' 0"	60'	49' 3"	34' 6"
40° Angle			45° Angle		
16'	12' 3"	10' 3"	16'	11' 3"	11' 3"
18'	13' 9"	11' 6"	18'	12' 9"	12' 9"
20'	15' 3"	12' 9"	20'	14' 3"	14' 3"
24'	18' 6"	15' 6"	24'	17' 0"	17' 0"
28'	21' 6"	18' 0"	28'	19' 9"	19' 9"
30'	23' 0"	19' 3"	30'	21' 3"	21' 3"
32'	24' 6"	20' 6"	32'	22' 9"	22' 9"
36'	27' 6"	23' 3"	36'	25' 6"	25' 6"
40'	30' 9"	25' 9"	40'	28' 3"	28' 3"
42'	32' 3"	27' 0"	42'	29' 9"	29' 9"
44'	33' 9"	28' 3"	44'	31' 0"	31' 0"
48'	36' 9"	30' 9"	48'	34' 0"	34' 0"
52'	39' 9"	33' 6"	52'	36' 9"	36' 9"
54'	41' 3"	34' 9"	54'	38' 3"	38' 3"
56'	43' 0"	36' 0"	56'	39' 6"	39' 6"
60'	46' 0"	38' 6"	60'	42' 6"	42' 6"