

# U.S. Wholegoods Price List

January 4, 2024  
All prices in USD

**Farmco Distributing Inc**  
**13619 S. DeWitt Rd**  
**Lansing MI 48906**  
**517-669-8391**



*\*MKX<sup>2</sup> 13-94 shown*



# Table of Contents

---

<b>12</b>	MK80 Series
<b>24</b>	MKX <sup>2</sup> Series
<b>35</b>	WRX Series
<b>42</b>	STX2 Series
<b>48</b>	UTX Series
<b>53</b>	WR & W Series
<b>59</b>	Utility Augers
<b>64</b>	Transfer Augers
<b>69</b>	Auger Tools
<b>70</b>	Optional Equipment

# FARM READY

## READY TO WORK WHEN YOU ARE!

From our manufacturing floor to your farm, AGI Westfield augers with the Farm Ready package are ready to work the moment they leave our facility. Our Farm Ready package can be added to any bundle so your auger is ready to work.



### MKX<sup>2</sup>10

Part #	List Price	Farm Ready	Package Net Price
01-MKX21063CBR	\$ 33,897.00	+ 1063FR	\$ 450.00
01-MKX21073CBR	\$ 35,450.00	+ 1073FR	\$ 500.00
01-MKX21083CBR	\$ 38,630.00	+ 1083FR	\$ 650.00

### FREIGHT & HANDLING

Horace, ND

Boone, IA

Decatur, IL

Grand Island, NE



Only available through the stock points listed above  
Does not include any fuel surcharges that may apply

### MKX<sup>2</sup>13

Part #	List Price	Farm Ready	Package Net Price
01-MKX21364CBR	\$ 46,399.00	+ 1364FR	\$ 550.00
01-MKX21374CBR	\$ 48,794.00	+ 1374FR	\$ 550.00
01-MKX21384CBR	\$ 52,769.00	+ 1384FR	\$ 950.00
01-MKX21394CBR	\$ 58,225.00	+ 1394FR	\$ 1,100.00
01-MKX213114CBR	\$ 72,126.00	+ 13114FR	\$ 1,350.00

Auger can be substituted with any CB option

### FREIGHT & HANDLING

Horace, ND

Boone, IA

Decatur, IL

Grand Island, NE



Only available through the stock points listed above  
Does not include any fuel surcharges that may apply

### MKX<sup>2</sup>16

Part #	List Price	Farm Ready	Package Net Price
01-MKX21685	\$ 92,912.00	+ 1685FR	\$ 1,550.00
01-MKX216105	\$ 108,896.00	+ 16105FR	\$ 2,100.00
01-MKX216125	\$ 121,738.00	+ 16125FR	\$ 2,450.00

### FREIGHT & HANDLING

Horace, ND

Boone, IA

Decatur, IL

Grand Island, NE



Only available through the stock points listed above  
Does not include any fuel surcharges that may apply

### FARM READY PACKAGES INCLUDE

Setup, Assembly, Farm Ready PDI check

ALL PRICES IN CAD

# FARM READY

## READY TO WORK WHEN YOU ARE!

From our manufacturing floor to your farm, AGI Westfield augers with the Farm Ready package are ready to work the moment they leave our facility. Our Farm Ready package can be added to any bundle so your auger is ready to work.



STX <sup>2</sup>			
Part #	List Price	Farm Ready	Package Net Price
01-STX20836SPHCBU	\$ 23,384.00	+ 0836FR (20 HP Kohler)	\$ 3,600.00
01-STX20841SPHCBU	\$ 24,474.00	+ 0841FR (20 HP Kohler)	\$ 3,650.00
01-STX20846SPHCBU	\$ 25,612.00	+ 0846FR (26.5 HP EFI Kohler)	\$ 4,300.00
01-STX20851SPHCBU	\$ 25,762.00	+ 0851FR (26.5 HP EFI Kohler)	\$ 4,350.00
01-STX21036SPHCBU	\$ 25,538.00	+ 1036FR (40 HP EFI Vanguard)	\$ 6,250.00
01-STX21041SPHCBU	\$ 26,154.00	+ 1041FR (40 HP EFI Vanguard)	\$ 6,300.00
01-STX21046SPHCBU	\$ 28,914.00	+ 1046FR (40 HP EFI Vanguard)	\$ 6,350.00
01-STX21051SPHCBU	\$ 30,202.00	+ 1051FR (40 HP EFI Vanguard)	\$ 6,400.00

Refer to price pages for SPHCB components.

### FREIGHT & HANDLING

Horace, ND

Boone, IA

Decatur, IL

Grand Island, NE



Only available through the stock points listed above  
Does not include any fuel surcharges that may apply

### FARM READY PACKAGES INCLUDE

Setup, Assembly, Farm Ready PDI check, Motor and Battery

ALL PRICES IN CAD



# MK 80 Swingaway Augers





It's not an  
ordinary auger...  
It's a Westfield.

## MK 80 Features

- Available in 51', 61' and 71' lengths
- Up to 3,900 bph
- A-frame design for maximum stability
- Trussing provides maximum support with full bin reach
- Choice of mechanical or hydraulic swing auger drives
- Equipped with heavy-duty constant velocity (CV) PTO shaft to eliminate vibrations for smoother running and less stress on the drive train
- Wear Edge™ flighting at critical grain transfer points (hopper, swing and removable boot flight) to improve auger performance and durability
- Spring loaded safety discharge door on intake hopper guards against main auger overloading
- Removable boot flight with Wear Edge™ to improve performance and durability of lower flighting



### Safety Discharge

Spring loaded safety discharge door on the intake hopper guards against main overloading.



### Trussing

Heavy-duty cable trussing provides maximum support with full bin reach.



### Single Cylinder Hydraulic Lift

Proven cylinder lift provides smooth, fast operation with minimal hydraulic requirements. Combined with the A-frame undercarriage, Westfield's design allows you to position your auger at the bin with ease.



### CV-PTO Shaft

Assures smooth operation with vibration-free running, longer wear and constant high capacity grain flow.

# MK80



## Hopper Lift Arm

Can be quickly changed from the left or right hand side of the auger to give the operator the convenience of unloading on both sides.



## Track & Lift Assist

Continuous 11 GA track is welded to the tube for increased stability and structural support. The multi-roller track shoe reduces the pressure needed to raise the auger and provides a lower transport position.

## Undercarriage & Wheels

Heavy-duty A-frame provides support and stability and comes with 15" transport wheels with 4-bolt cast iron hubs.





# Hopper Options



## Standard Hopper

Quickly switches to right or left hand operation. A vertical transport position provides for quick, easy clean-out.

- 5" rubber extension – holds more grain while reducing spillage
- Convenient boot clean-out and service access doors

## Add These Optional Features

### Flex Spouts

Directs grain flow – reduces spillage. Available in regular or no-snag designs.



### Corn Screen

Up to 4' long. Available on all models. Factory installed on the swing hopper tube.

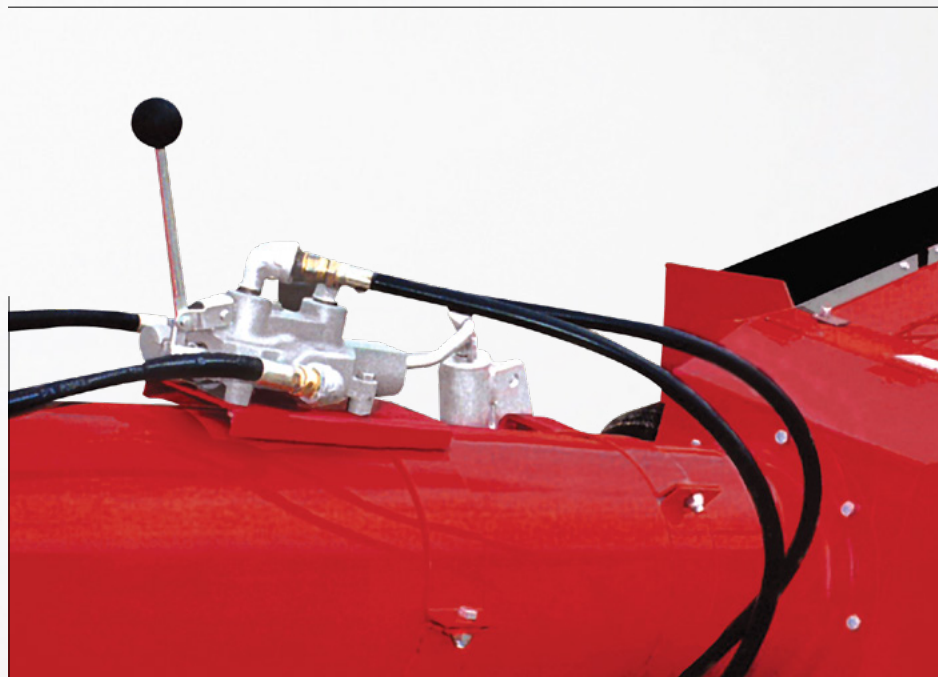

### Right Angle Drive

Assists operation in limited space situations. Allows a full arc on opposite side of tractor.



### Reverser Kit

Ability to reverse all flights. Allows for quick and easy clean-out.

## Upgrade to the **Hydraulic Power Swing**

- Easy installation
- Top wind jack to adjust wheel traction
- Two wheel drive design
- Hydraulic drive moves swing hopper
- Convenient tube mounted control valve
- Complete with hydraulic hoses

# MK80

AUGER SPECIFICATIONS			
	MK80-51	MK80-61	MK80-71
TUBING GAUGE	14 GA Welded Steel		
MAIN FLIGHTING	10 GA Stretched & Welded		
WEAR EDGE™ (REINFORCED FLIGHT)	10 GA Ribbon Welded Wear Edge™ on Critical Grain Transfer Points including the Intake Hopper Flighting, Initial Incline Flighting & Boot Flighting		
FLIGHTING SHAFT	1.66" x 11 GA Tubing		
PSI REQUIRED TO RAISE AUGER	850 PSI	950 PSI	1200 PSI
PTO LINE DRIVE	14 Series with $\frac{5}{16}$ " Shear Bolt		
HP REQUIRED	40	45	50
TUBE TRUSSING	$\frac{5}{16}$ " Aircraft Type Galvanized Cable		
TRACK	High Yield 11 GA Roll Formed		
TRACK SHOE	Double 2 $\frac{3}{4}$ " Rollers		
UNDERCARRIAGE	3" x 11 GA Frame		
AXLE	2 $\frac{1}{2}$ " x 2 $\frac{1}{2}$ " x $\frac{1}{8}$ " Wall Square Tubing		
HUBS & WHEELS	4 Bolt Agricultural Type Hubs - 15" Wheels		
WHEEL TREAD	106"	112"	118"
HYDRAULIC LIFT	One 4" Cylinder with $\frac{5}{16}$ " Aircraft Cable		
TRANSPORT HEIGHT	12' 10"	13' 6"	14' 6"
TIRES REQUIRED	15" Agricultural Tires		
*STANDARD HOPPER HEIGHT	10 $\frac{1}{2}$ "		
APPROXIMATE HYDRAULIC FLUID REQUIRED TO RAISE AUGER	6.2 Litres	7.5 Litres	9.0 Litres

\*Hopper height is to top of metal portion (add 4" for the rubber extension).

Note: Capacities may vary according to the commodity and moisture content. Specifications and design are subject to change without notice.

DISCLAIMER: This auger was proudly designed to handle dry, free-flowing grains up to a maximum of 65 lb/bu (52 lb/cf). Any usage of this auger outside of this is not authorized by AGI.

HEIGHT, REACH & WHEEL SPECIFICATIONS

	A	B	C	D	E	F	G	H	I	J
	Height Lowered	Height Halfway	Height Raised	Reach Lowered	Reach Halfway	Reach Raised	Height at Liftarms	Height at Wheels	Reach to Liftarms	Reach to Wheels
MK80-51	10' 10"	23' 7"	34' 8"	23' 9"	22'	19' 6"	14' 10"	19'	18' 5"	19' 6"
MK80-61	11' 5"	27'	40' 6"	28' 10"	27'	23' 3"	17'	22' 4"	22' 6"	23' 3"
MK80-71	12' 6"	32' 8"	46' 6"	33' 7"	30' 9"	27' 2"	20' 7"	25' 10"	25' 9"	26' 10"

Heights measured from bottom of auger spout to ground.

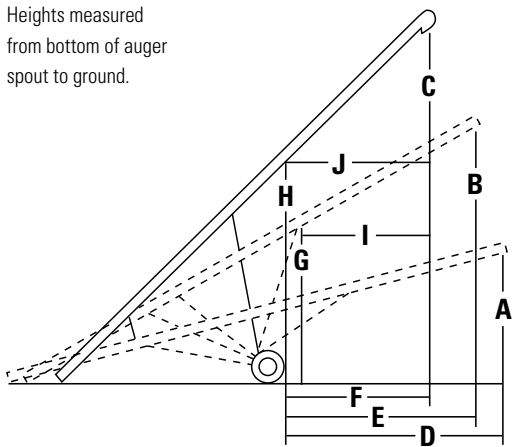



Part Number	Description	Weight (lbs)	List Price	Freight
<b>MK 8 x 51 AUGER</b>				
01-MK0851G	Auger with Mechanical Drive Standard Hopper	1870	\$17,284	\$1,728
01-MK0851GS	Auger with Mechanical Drive Standard Hopper and	1870	\$17,925	\$1,793
01-MK0851H	Auger with Hydraulic Drive Standard Hopper	1835	\$17,610	\$1,761
01-MK0851HS	Auger with Hydraulic Drive Standard Hopper and	1835	\$18,251	\$1,825

<b>MK 8 x 61 AUGER</b>				
01-MK0861G	Auger with Mechanical Drive Standard Hopper	2110	\$18,670	\$1,867
01-MK0861GS	Auger with Mechanical Drive Standard Hopper and	2110	\$19,310	\$1,931
01-MK0861H	Auger with Hydraulic Drive Standard Hopper	2075	\$18,974	\$1,897
01-MK0861HS	Auger with Hydraulic Drive Standard Hopper and	2075	\$19,614	\$1,961

<b>MK 8 x 71 AUGER</b>				
01-MK0871G	Auger with Mechanical Drive Standard Hopper	2330	\$20,589	\$2,000
01-MK0871GS	Auger with Mechanical Drive Standard Hopper and	2330	\$21,229	\$2,000
01-MK0871H	Auger with Hydraulic Drive Standard Hopper	2295	\$21,525	\$2,000
01-MK0871HS	Auger with Hydraulic Drive Standard Hopper and	2295	\$22,166	\$2,000

<b>OPTIONS</b>				
05-A147	8" Corn Screen	20	\$715	\$72
05-A160	MK80/100 Standard Hopper Tarp	6	\$389	\$39
05-A164	Poly Bucket Flex Spout, 36" - 5 section, Fits 8/10"	14	\$274	\$27
05-A199	MK80 Right Angle Drive	125	\$3,637	\$364
	*Credit for 1063/73 Complete PTO Return	29	\$687	\$69

**AGI  WESTFIELD**

**SWINGAWAY AUGERS**

*MKX<sup>2</sup>*

# GRAIN MOVING SOLUTIONS

Since 1951, AGI Westfield augers have led the auger industry by improving the efficiency and bottom line of producers. AGI Westfield grain augers are manufactured with quality materials, components and features to provide value and performance.

## KEY UPDATES

### New open discharge spout

- More efficient flow, leading to a reduction in hp requirements and plugging

### Durable boot

- Separate abrasion resistant (AR) boot flighting with removable shafts provides a longer lifespan and makes servicing easier (13" and 16")
- Tapered lower bearing increases lifespan (13")
- Hanger bearing to help support the boot flight reducing operation noise (13" and 16")
- Easier inspections and servicing with dual side boot clean-out doors (13")
- Updated PTO holder for easier in-transport hook up (13")
- Updated hose holder (13")

### Responsive steerable axles

- Easy maneuvering around tight bin yards and corners
- Optional on 13" and standard on 16"

### Additional updates

- 30' tubes and flighting lessens connections and reduces noise
- Transition neck flight support provides better alignment and improves lifespan (13" and 16")
- Optional downspout
- Improved right angle drive to increase gearbox stability (13")
- Right angle drive compatible with speed reducer allows for 90-degree tractor positioning while reducing speeds from 1000 rpm to 540 rpm operating speed



**2** YEAR WARRANTY



# MKX<sup>2</sup> 10

UP TO 6,000 BPH  
53' - 83' LENGTHS

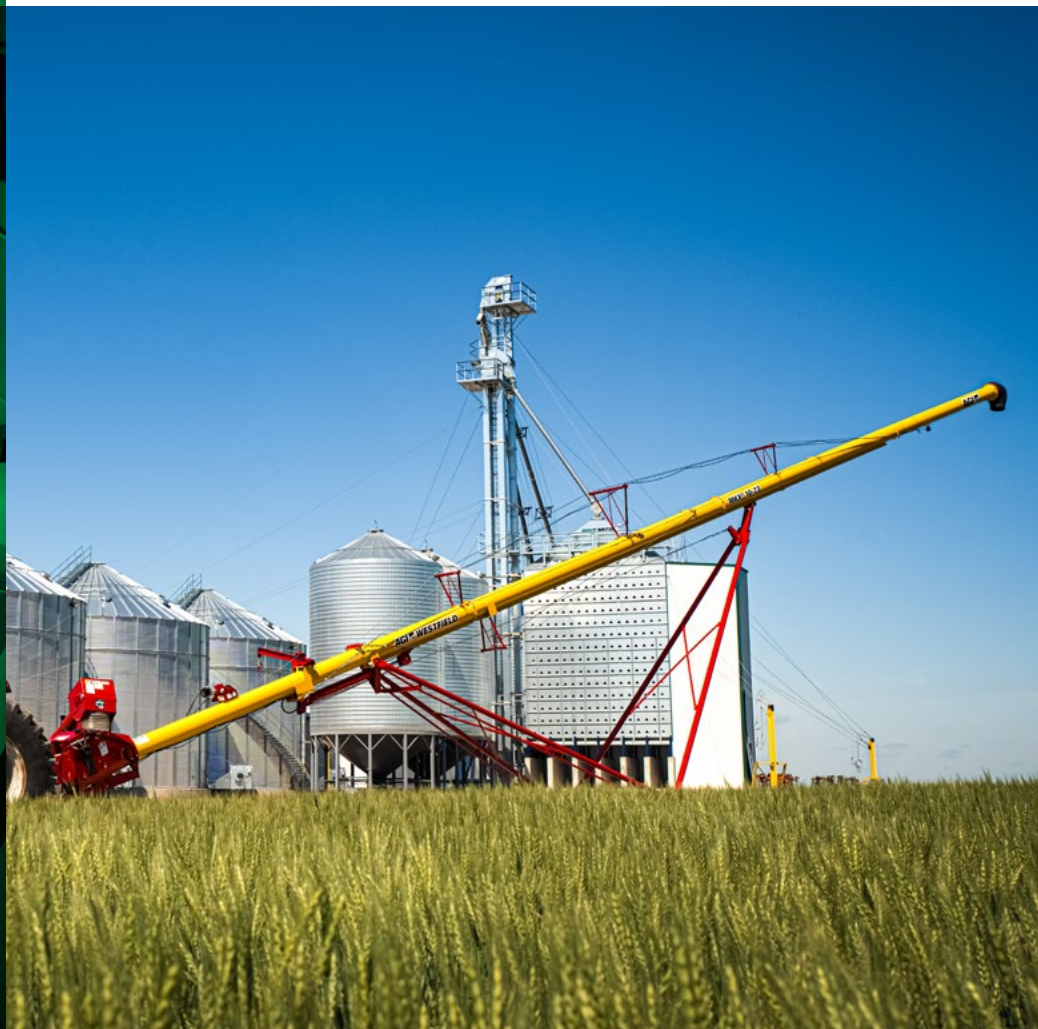

## KEY FEATURES

- New open discharge spout decreases horsepower requirements
- Aircraft cable trussing
- Stable A-frame support (53'-83')
- Wide standing axles

## OPTIONS

- Hydraulic hopper winch
- Electric and hydraulic power swing
- Reverser kit
- Corn screen
- Poly flex spout
- Right angle drive
- LED work lights





## Find the right auger

	MKX <sup>2</sup> 10-53	MKX <sup>2</sup> 10-63	MKX <sup>2</sup> 10-73	MKX <sup>2</sup> 10-83
TUBE GAUGE	12 ga			
TUBE CONNECTORS	Heavy-duty 3/16" (0.5 cm) angle flange			
MAIN FLIGHTING	9" (22.9 cm) OD x 7 ga stretched and welded with Wear Edge Technology™ on critical points			
WEAR EDGE TECHNOLOGY™ (REINFORCED FLIGHT)	1/4" (0.6 cm) plus 10 ga ribbon weld = 5/16" (0.8 cm) Wear Edge Technology™ on critical grain transfer points			
FLIGHTING SHAFT	High strength 2" (5.1 cm) OD x 11 ga tubing square flight connection			
UPPER BEARING	2" (5.1 cm) taper roller bearing assembly			
LOWER BEARING	1 1/2" (3.8 cm) pillow block greaseable ball bearing			
TUBE TRUSSING	5/16" (0.8 cm) aircraft type galvanized steel cable			3/8" (1 cm) aircraft type galvanized steel cable
HYDRAULIC LIFT	Single 4" (10.2 cm) cylinder with 5/16" (0.8 cm) aircraft cable			One 4 1/2" (11.4 cm) cylinder with 3/8" (1 cm) aircraft cable
UNDERCARRIAGE	3" (7.6 cm) x 11 ga A-frame		3.5" (9 cm) x 11 ga HSS tubing	4" (10.2 cm) x 10 ga HSS tubing
AXLE	2 1/2" (6.4 cm) x 2 1/2" (6.4 cm) x 1/8" (0.3 cm) wall square tubing			3 1/2" (8.9 cm) x 3 1/2" (8.9 cm) x 3/16" (0.5 cm) wall square tubing
HUB	4-bolt agricultural type			Heavy-duty 6-bolt iron hubs
TIRES	15" (38.1 cm)			16" (40.6 cm)
PTO SHAFT	14E constant velocity with 5/16" (8 mm) shear bolt			35E constant velocity with 5/16" (8 mm) shear bolt
PARKING JACK	2000 lbs (907.2 kg) side wind			
SPROCKET & CHAIN	Hardened tooth sprocket with #60 chain			
LOW PROFILE HOPPER DIMENSIONS	60" (152.4 cm) length x 40" (101.6 cm) width x 10" (25.4 cm) height with flat free tires			
PSI REQUIRED TO RAISE AUGER	1000 psi (68.9 bar)	1200 psi (82.7 bar)	1400 psi (96.5 bar)	1800 psi (124.1 bar)
HP REQUIRED (WITH DRY WHEAT)	45-50 hp	50-60 hp	55-65 hp	65-75 hp
WHEEL TREAD	106" (2.7 m)	112" (2.8 m)	118" (3 m)	112" - 144" (2.8 m - 3.7 m)
TRANSPORT HEIGHT (18" HITCH)	12' 6" (3.8 m)	13' 6" (4.1 m)	14' 8" (4.5 m)	13' (4 m)

## SPECIFICATIONS

	A	B	C	D	E	F	G	H	I	J
<b>MKX<sup>2</sup></b>	HEIGHT LOWERED	HEIGHT HALFWAY	HEIGHT RAISED	REACH LOWERED	REACH HALFWAY	REACH RAISED	HEIGHT AT LIFTARMS	HEIGHT AT WHEELS	REACH TO LIFTARMS	REACH TO WHEELS
<b>1036</b>	9'-8" (2.95 m)	16'-7" (5.1 m)	21'-10" (6.7 m)	17'-9" (5.4 m)	17'-11" (5.5 m)	18'-6" (5.6 m)	9'-9" (3 m)	10'-6" (3.2 m)	17'-5" (5.3 m)	19'-9" (6 m)
<b>1053</b>	10'-8" (3.3 m)	24'-6" (7.5 m)	36'-7" (11.2 m)	27'-1" (8.3 m)	25'-1" (7.6 m)	22'-5" (6.8 m)	14'-10" (4.5 m)	16'-10" (5.1 m)	21'-11" (6.7 m)	24'-7" (7.5 m)
<b>1063</b>	11'-7" (3.5 m)	26'-3" (8 m)	41'-6" (12.6 m)	32'-3" (9.8 m)	30'-6" (9.3 m)	26'-9" (8.2 m)	16'-5" (5 m)	19'-2" (5.8 m)	24'-9" (7.5 m)	29'-4" (8.9 m)
<b>1073</b>	12'-10" (3.9 m)	29'-8" (9 m)	48'-4" (14.7 m)	36'-10" (11.2 m)	34'-8" (10.6 m)	29'-7" (9 m)	19' (5.8 m)	22'-2" (6.8 m)	27'-4" (8.3 m)	33'-6" (10.2 m)
<b>1083</b>	11'-3" (3.4 m)	34'-5" (10.5 m)	55' (16.8 m)	43'-9" (13.3 m)	40'-4" (12.3 m)	33'-3" (10.1 m)	21'-7" (6.6 m)	25' (7.6 m)	31'-6" (9.6 m)	37'-9" (11.5 m)

Heights measured from bottom of auger spout to ground.

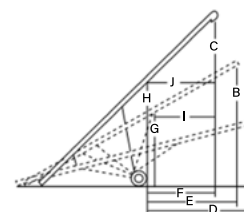

# MKX<sup>2</sup> 13

UP TO 11,000 BPH  
64' - 114' LENGTHS

## KEY FEATURES

- New open discharge spout decreases horsepower requirements
- Aircraft cable trussing
- Stable A-frame support (64'-114')
- Wide standing axles
- Rigid steel trussing (84' and up)

## OPTIONS

- Steerable axles
- Hydraulic hopper winch
- Electric and hydraulic power swing
- X-Tend hopper
- X-Over hopper
- Poly flex spout
- Speed reducer-reverser
- Reverser kit
- Corn screen
- Right angle drive
- Transport lights
- LED work lights



See new  
axles  
in action



## Find the right auger

	MKX <sup>2</sup> 13-64	MKX <sup>2</sup> 13-74	MKX <sup>2</sup> 13-84	MKX <sup>2</sup> 13-94	MKX <sup>2</sup> 13-114
TUBE GAUGE	12 ga				
TUBE CONNECTORS	Heavy-duty ¼" (0.6 cm) angle flange				
MAIN FLIGHTING	11 ¾" (29.8 cm) OD x ¼" (0.6 cm) stretched and welded with Wear Edge Technology™ on critical points				
WEAR EDGE TECHNOLOGY™ (REINFORCED FLIGHT)	¼" (0.6 cm) plus 10 ga ribbon weld = ⅝" (0.8 cm) Wear Edge Technology™ on critical grain transfer points				
AR BOOT FLIGHT	¼" (0.6 cm)				
FLIGHTING SHAFT	High strength 3" (7.6 cm) OD x 11 ga tubing square flight connection				
UPPER BEARING	2" (5.1 cm) taper roller bearing assembly				
GREASELESS HANGER BEARING FOR BOOT (NEW)	1 ⅞" (4.9 cm) ID, triple seal				
LOWER BEARING	Custom 2" (5.1 cm) taper roller bearing assembly				
TUBE TRUSSING	⅜" (1 cm) aircraft type galvanized steel cable		Combination 2 ½" (6.4 cm) x 11 ga steel tubing & ⅜" (1 cm) galvanized cable		
HYDRAULIC LIFT	Dual 4" (10.2 cm) single acting cylinders with ⅝" (0.8 cm) aircraft cable		Dual 4 ½" (11.4 cm) cylinders with ⅜" (1 cm) aircraft cable		
UNDERCARRIAGE	4" (10.2 cm) x 11 ga A-frame		3" (7.6 cm) x 6" (15.2 cm) HSS tubing	4" (10.2 cm) x 8" (20.3 cm) HSS tubing	
AXLE	3" (7.6 cm) x 3" (7.6 cm) square tubing		3 ½" (8.9 cm) x 3 ½" (8.9 cm) square tubing		
HUB	6-bolt agricultural type				
TIRES	16' (40.6 cm) TRF				
PTO SHAFT	35E constant velocity with ⅜" (1 cm) shear bolt		55E constant velocity with 2-bolt shear		
PARKING JACK	5000 lbs (2268 kg) side wind				
SPROCKET & CHAIN	Hardened tooth sprocket with HD #80 chain				
LOW PROFILE HOPPER DIMENSIONS	60" (152.4 cm) length x 40" (101.6 cm) width x 10" (25.4 cm) height with flat free tires				
PSI REQUIRED TO RAISE AUGER	1600 psi (110.3 bar)		1800 psi (124.1 bar)	2000 psi (137.9 bar)	2100 psi (144.8 bar)
HP REQUIRED (WITH DRY WHEAT)	85-100 hp	110-125 hp	115-155 hp	125-165 hp	140-185 hp
WHEEL TREAD	124" (315 cm)	130" (330.2 cm)	146" - 182" (370.8 cm - 462.3 cm)		
TRANSPORT HEIGHT (18" HITCH)	12' 8" (3.9 m)	14' 3" (4.3 m)	13' (4 m)	13' 3" (4 m)	14' 5" (4.4 m)

## SPECIFICATIONS

	A	B	C	D	E	F	G	H	I	J
MKX <sup>2</sup>	HEIGHT LOWERED	HEIGHT HALFWAY	HEIGHT RAISED	REACH LOWERED	REACH HALFWAY	REACH RAISED	HEIGHT AT LIFTARMS	HEIGHT AT WHEELS	REACH TO LIFTARMS	REACH TO WHEELS
<b>1364</b>	10'-2" (3.1 m)	26' (7.9 m)	40'-3" (12.3 m)	31'-1" (9.5 m)	29'-11" (9.1 m)	27'-8" (8.4 m)	15'-10" (4.8 m)	17'-8" (5.4 m)	26'-7" (8.1 m)	31'-11" (9.7 m)
<b>1374</b>	11'-11" (3.6 m)	29'-8" (9 m)	45'-7" (13.9 m)	35'-7" (10.8 m)	34' (10.4 m)	31'-2" (9.5 m)	18'-6" (5.6 m)	20'-7" (6.3 m)	29' (8.8 m)	35'-11" (10.9 m)
<b>1384</b>	10'-6" (3.2 m)	36'-3" (11 m)	59'-5" (18.1 m)	44'-10" (13.7 m)	40'-9" (12.4 m)	31'-5" (9.6 m)	23'-4" (7.1 m)	27'-11" (8.5 m)	29'-11" (9.1 m)	35' (10.7 m)
<b>1394</b>	10'-6" (3.2 m)	37'-3" (11.4 m)	60'-3" (18.4 m)	45'-8" (13.9 m)	42'-11" (13 m)	37'-1" (11.3 m)	24'-10" (7.6 m)	29'-9" (9.1 m)	31'-9" (9.7 m)	39'-10" (12.1 m)
<b>13114</b>	12' (3.7 m)	41'-2" (12.5 m)	68'-11" (21 m)	56'-1" (17.1 m)	53'-4" (16.6 m)	46'-2" (14.1 m)	27'-6" (8.4 m)	33'-11" (10.3 m)	38'-3" (11.7 m)	47'-1" (14.4 m)

Heights measured from bottom of auger spout to ground.

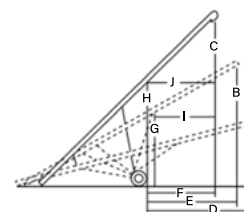

# MKX<sup>2</sup> 16

UP TO 23,000 BPH  
85' - 125' LENGTHS



See new  
axles  
in action

## KEY FEATURES

- New open discharge spout
- Rigid steel trussing
- Stable A-frame support
- Standard steerable axles

## OPTIONS

- X-Tend hopper
- Poly flex spout



## Find the right auger

	MKX <sup>2</sup> 16-85	MKX <sup>2</sup> 16-105	MKX <sup>2</sup> 16-125
TUBE GAUGE	10 ga		
TUBE CONNECTORS	¼" (0.6 cm) angle flange		
MAIN FLIGHTING	15" (38.1 cm) x ¼" (0.6 cm) stretched & welded		
WEAR EDGE TECHNOLOGY™ (REINFORCED FLIGHT)	¼" (0.6 cm) main flighting with Wear Edge Technology™ on critical grain transfer points		
AR BOOT FLIGHT	¼" (0.6 cm)		
FLIGHTING SHAFT	3.5" (8.9 cm) x 11 ga tubing; square flight connector		
GREASELESS HANGER BEARING FOR BOOT (NEW)	2 ⅜" (6 cm) ID, triple seal		
UPPER BEARING	2" (5.1 cm) taper roller bearing assembly		
SPEED REDUCER GEARBOX	Enclosed, cast casing, 1000 rpm reducing gearbox (540 rpm) with reversing capability		
TUBE TRUSSING	3.5" (8.9 cm) x 11 ga tubing; ½" (1.3 cm) cable stays		
HYDRAULIC LIFT	2" (5.1cm) x 4 ½" (11.4 cm) cylinder with ⅜" (1 cm) cable	2" (5.1cm) x 6 ½" (16.5 cm) bore cylinders; ½" (1.3 cm) aircraft cable	
UNDERCARRIAGE	4" (10.2cm) x 8" (20.3cm) HSS tubing		
AXLE	4" (10.2 cm) x 4" (10.2 cm) x ⅜" (0.5cm) tubing; 4" (10.2 cm) x 4" (10.2 cm) x ¼" (0.6 cm) on extensions		
HUB	8-bolt agricultural type		
TIRES	22.5" (57.2 cm) agricultural tires		
PTO SHAFT	50E double CV with 2-bolt shear		
PARKING JACK	12,000 lbs (5443.1 kg)		
LOW PROFILE HOPPER DIMENSIONS	68" (172.7 cm) length x 46 ½" (121.9 cm) width x 11" (27.9 cm) height with flat free tires		
PSI REQUIRED TO RAISE AUGER	1800 psi (124.1 bar)	1700 psi (117.2 bar)	2000 psi (137.9 bar)
HP REQUIRED (WITH DRY WHEAT)	150 - 175 hp	170 - 200 hp	195 - 225 hp
WHEEL TREAD	148" - 182" (375.9 - 462.3 cm)		
TRANSPORT HEIGHT (18" HITCH)	15' 6" (4.7 m)	15' 6" (4.7 m)	17' 6" (5.3 m)

## SPECIFICATIONS

	A	B	C	D	E	F	G	H	I	J
<b>MKX<sup>2</sup></b>	HEIGHT LOWERED	HEIGHT HALFWAY	HEIGHT RAISED	REACH LOWERED	REACH HALFWAY	REACH RAISED	HEIGHT AT LIFTARMS	HEIGHT AT WHEELS	REACH TO LIFTARMS	REACH TO WHEELS
<b>1685</b>	12'-7" (3.8 m)	33'-4" (10.1 m)	47'-3" (14.4 m)	46' (14 m)	43'-4" (13.2 m)	39'-10" (12.1 m)	23'-8" (7.2 m)	28'-7" (8.7 m)	26'-4" (8 m)	31'-9" (9.7 m)
<b>16105</b>	12' (3.7 m)	42'-11" (13.1 m)	77'-5" (23.6 m)	54'-10" (16.7 m)	51'-3" (15.6 m)	40'-7" (12.4 m)	30'-2" (9.2 m)	36'-5" (11.1 m)	32'-1" (9.8 m)	42'-8" (13 m)
<b>16125</b>	14'-3" (4.3 m)	48'-6" (14.8 m)	87'-10" (26.8 m)	68'-8" (20.9 m)	63'-8" (19.4 m)	48'-9" (14.9 m)	31'-6" (9.6 m)	37'-1" (11.3 m)	44'-4" (13.5 m)	56'-9" (17.3 m)

Heights measured from bottom of auger spout to ground.

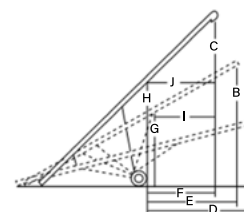

# HOPPER

## OPTIONS



See X-Over  
in action

### **X-TEND**

13" // 16"

#### KEY FEATURES

- Retracts and moves side-to-side
- Low profile hopper with dual flighting
- Hydraulic controls

### **X-OVER**

13"

#### KEY FEATURES

- Drive over belt-driven hopper
- Reinforced drive over deck and ramps
- Mechanical drive hopper (NEW)

### **POWER SWING**

10" // 13" // 16"

#### KEY FEATURES

- 12V remote electric or hydraulic drive





See X-Tend  
in action





Part Number	Description	Weight (lbs)	List Price	Back Freight
-------------	-------------	--------------	------------	--------------

### MKX<sup>2</sup> 10 x 36 AUGER

01-MKX21036G	Auger with Standard Hopper	2217	\$17,510	1,751
01-MKX21036	Auger with Low Profile Hopper	2397	\$19,261	1,926

### MKX<sup>2</sup> 10 x 53 AUGER

01-MKX21053G	Auger with Standard Hopper	2862	\$23,774	2,000
01-MKX21053	Auger with Low Profile Hopper	3042	\$24,818	2,000
01-MKX21053CBH	Complete Bundle with Hydraulic Power Swing	3421	\$31,004	2,000
01-MKX21053CB	Complete Bundle with Electric Power Swing	3401	\$33,096	2,000
01-MKX21053CBHR	Complete Bundle with Hydraulic Power Swing and Reverser	3442	\$32,070	2,000
01-MKX21053CBR	Complete Bundle with Electric Power Swing and Reverser	3422	\$34,162	2,000

**Complete Bundle Includes: Low Profile Hopper, Hydraulic Hopper Winch, Work Light Kit**

### MKX<sup>2</sup> 10 x 63 AUGER

01-MKX21063G	Auger with Standard Hopper	3151	\$24,494	2,000
01-MKX21063GS	Auger with Standard Hopper and Corn Screen	3161	\$25,203	2,000
01-MKX21063	Auger with Low Profile Hopper	3331	\$25,570	2,000
01-MKX21063S	Auger with Low Profile Hopper and Corn Screen	3341	\$26,278	2,000
01-MKX21063CBH	Complete Bundle with Hydraulic Power Swing	3710	\$31,756	2,000
01-MKX21063CB	Complete Bundle with Electric Power Swing	3690	\$33,848	2,000
01-MKX21063CBHR	Complete Bundle with Hydraulic Power Swing and Reverser	3731	\$32,822	2,000
01-MKX21063CBR	Complete Bundle with Electric Power Swing and Reverser	3711	\$34,914	2,000

**Complete Bundle Includes: Low Profile Hopper, Hydraulic Hopper Winch, Work Light Kit**

### MKX<sup>2</sup> 10 x 73 AUGER

01-MKX21073G	Auger with Standard Hopper	3519	\$26,102	2,000
01-MKX21073GS	Auger with Standard Hopper and Corn Screen	3529	\$26,811	2,000
01-MKX21073	Auger with Low Profile Hopper	3699	\$27,169	2,000
01-MKX21073S	Auger with Low Profile Hopper and Corn Screen	3709	\$27,878	2,000
01-MKX21073CBH	Complete Bundle with Hydraulic Power Swing	4080	\$33,356	2,000
01-MKX21073CB	Complete Bundle with Electric Power Swing	4060	\$35,447	2,000
01-MKX21073CBHR	Complete Bundle with Hydraulic Power Swing and Reverser	4101	\$34,422	2,000
01-MKX21073CBR	Complete Bundle with Electric Power Swing and Reverser	4081	\$36,514	2,000

**Complete Bundle Includes: Low Profile Hopper, Hydraulic Hopper Winch, Work Light Kit**

### MKX<sup>2</sup> 10 x 83 AUGER

01-MKX21083G	Auger with Standard Hopper	4196	\$29,634	2,000
01-MKX21083GS	Auger with Standard Hopper and Corn Screen	4206	\$30,343	2,000
01-MKX21083	Auger with Low Profile Hopper	4376	\$30,445	2,000
01-MKX21083S	Auger with Low Profile Hopper and Corn Screen	4386	\$31,153	2,000
01-MKX21083CBH	Complete Bundle with Hydraulic Power Swing	4758	\$36,631	2,000
01-MKX21083CB	Complete Bundle with Electric Power Swing	4738	\$38,723	2,000
01-MKX21083CBHR	Complete Bundle with Hydraulic Power Swing and Reverser	4778	\$37,697	2,000
01-MKX21083CBR	Complete Bundle with Electric Power Swing and Reverser	4758	\$39,789	2,000

**Complete Bundle Includes: Low Profile Hopper, Hydraulic Hopper Winch, Work Light Kit**

### OPTIONS

05-A148	10" Corn Screen	27	\$791	79
05-A164	Poly Bucket Flex Spout, 36" - 5 section, Fits 8/10" Augers	14	\$274	27
05-A184	MKX/X100/MKX/X130 Low Profile Hopper Tarp	9	\$486	49
05-A269	MKX100 Remote Electric PowerSwing (2016 and older)	230	\$5,741	574
05-A270	MKX100 PowerSwing Hydraulic (2016 and older)	221	\$3,439	344





Part Number	Description	Weight (lbs)	List Price	Back Freight
05-A271	Additional Remote Control	1	\$432	\$43
05-A282	No Snag Flex Spout, 3 section, Fits 10" Augers	8	\$357	\$36
05-A292	MKX/X100 G Reverser Kit	43	\$1,190	\$119
05-A293	MKX/X100 Right Angle Drive	133	\$3,677	\$368
05-A296	MKX/X100 Hydraulic Hopper Lift Kit	76	\$2,521	\$252
05-A331	Hopper Weight for Lift Cable	15	\$156	\$16
05-A348	1063 Work Light Kit (works for MKX2 1053)	21	\$907	\$91
05-A350	1073 Work Light Kit	17	\$907	\$91
05-A352	1083 Work Light Kit	18	\$907	\$91
05-A362	10" Hydraulic Landing Gear Power Swing	310	\$4,054	\$405
05-A363	10" Remote Electric Landing Gear Power Swing	290	\$6,389	\$639
05-A448	MKX/X10 Spout Head-Hose Ring Replacement	17	\$304	\$30
05-A515	MKX2/X2/HX2 10" Parts Kit		\$334	\$33
05-A524	10" Standard Hopper Assembly	214	\$2,830	\$283
05-A525	MKX2 10" Low-Profile Hopper Assembly	389	\$3,880	\$388

### MKX<sup>2</sup> 10"

14-X100	*Credit for 1063/73 Complete PTO Return	29	\$687	
14-X103	*Credit for 1083 Complete PTO Return	72	\$1,206	

### MKX<sup>2</sup> 13 x 64 AUGER

01-MKX21364	Auger with Low Profile Hopper	4807	\$38,526	\$2,000
01-MKX21364CBH	Complete Bundle with Hydraulic Power Swing	5205	\$44,212	\$2,000
01-MKX21364CB	Complete Bundle with Electric Power Swing	5195	\$46,322	\$2,000
01-MKX21364CBHR	Complete Bundle with Hydraulic Power Swing and	5242	\$45,681	\$2,000
01-MKX21364CBR	Complete Bundle with Electric Power Swing and	5232	\$47,791	\$2,000
01-MKX21364CBRR	Complete Bundle with Electric Power Swing and	5232	\$52,484	\$2,000

**Complete Bundle Includes: Low Profile Reducer/Reverser Bundles Include 21 Spline CV-PTO (05-A219) Hopper, Hydraulic Hopper Winch, and Work Light Kit**

### MKX<sup>2</sup> 13 x 74 AUGER

01-MKX21374	Auger with Low Profile Hopper	5225	\$40,993	\$2,000
01-MKX21374S	Auger with Low Profile Hopper and Corn Screen	5235	\$42,030	\$2,000
01-MKX21374L	Basic Auger with 15' Swing Tube	5451	\$42,688	\$2,000
01-MKX21374CBH	Complete Bundle with Hydraulic Power Swing	5625	\$46,679	\$2,000
01-MKX21374CB	Complete Bundle with Electric Power Swing	5615	\$48,789	\$2,000
01-MKX21374CBHR	Complete Bundle with Hydraulic Power Swing and	5661	\$48,147	\$2,000
01-MKX21374CBR	Complete Bundle with Electric Power Swing and	5651	\$50,258	\$2,000
01-MKX21374CBRR	Complete Bundle with Electric Power Swing and	5652	\$54,951	\$2,000
01-MKX21374CBHL	Complete Bundle with 15' Hydraulic Power Swing Tube	5855	\$48,374	\$2,000
01-MKX21374CBL	Complete Bundle with 15' Electric Power Swing Tube	5845	\$50,484	\$2,000
01-MKX21374CBHRL	Complete Bundle with 15' Hydraulic Power Swing Tube	5891	\$49,843	\$2,000
01-MKX21374CBRL	Complete Bundle with 15' Electric Power Swing Tube	5881	\$51,953	\$2,000

**Complete Bundle Includes: Low Profile Hopper, Hydraulic Hopper Winch, and Work Light Kit Reducer/Reverser Bundles Include 21 Spline CV-PTO (05-A219)**

### MKX<sup>2</sup> 13 x 84 AUGER

01-MKX21384	Auger with Low Profile Hopper	7176	\$44,608	\$2,000
01-MKX21384S	Auger with Low Profile Hopper and Corn Screen	7187	\$45,645	\$2,000
01-MKX21384L	Basic Auger with 15' Swing Tube	7412	\$46,518	\$2,000
01-MKX21384CBH	Complete Bundle with Hydraulic Power Swing	7612	\$50,773	\$2,000
01-MKX21384CB	Complete Bundle with Electric Power Swing	7602	\$52,883	\$2,000
01-MKX21384CBHR	Complete Bundle with Hydraulic Power Swing and	7652	\$52,242	\$2,000
01-MKX21384CBR	Complete Bundle with Electric Power Swing and	7642	\$54,352	\$2,000
01-MKX21384CBRR	Complete Bundle with Electric Power Swing and	7637	\$59,143	\$2,000



Part Number	Description	Weight (lbs)	List Price	Back Freight
01-MKX21384CBHL	Complete Bundle with 15' Hydraulic Power Swing	7858	52,682	\$2,000
01-MKX21384CBL	Complete Bundle with 15' Electric Power Swing Tube	7848	54,793	\$2,000
01-MKX21384CBHRL	Complete Bundle with 15' Hydraulic Power Swing	7893	54,151	\$2,000
01-MKX21384CBRL	Complete Bundle with 15' Electric Power Swing Tube	7883	56,262	\$2,000
01-MKX21384XTEND	Auger with X-Tend Hopper	8085	67,763	\$2,000
01-MKX21384XTENDRR	Auger with X-Tend Hopper and Reducer/Reverser	8171	74,022	\$2,000

**Complete Bundle Includes: Low Profile Hopper, Hydraulic Hopper Winch, Transport and Work Light Kit**

**Reducer/Reverser Bundles Include 21 Spline CV-PTO (05-A246)**

### MKX<sup>2</sup> 13 x 94 AUGER

01-MKX21394	Auger with Low Profile Hopper	7977	50,215	\$2,000
01-MKX21394S	Auger with Low Profile Hopper and Corn Screen	7988	51,252	\$2,000
01-MKX21394L	Basic Auger with 15' Swing Tube	8212	52,151	\$2,000
01-MKX21394CBH	Complete Bundle with Hydraulic Power Swing	8420	56,393	\$2,000
01-MKX21394CB	Complete Bundle with Electric Power Swing	8410	58,503	\$2,000
01-MKX21394CBHR	Complete Bundle with Hydraulic Power Swing and	8456	57,861	\$2,000
01-MKX21394CBR	Complete Bundle with Electric Power Swing and	8446	59,972	\$2,000
01-MKX21394CBRR	Complete Bundle with Electric Power Swing and	8442	64,762	\$2,000
01-MKX21394CBHL	Complete Bundle with 15' Hydraulic Power Swing	8660	58,329	\$2,000
01-MKX21394CBL	Complete Bundle with 15' Electric Power Swing Tube	8650	60,439	\$2,000
01-MKX21394CBHRL	Complete Bundle with 15' Hydraulic Power Swing	8696	59,798	\$2,000
01-MKX21394CBRL	Complete Bundle with 15' Electric Power Swing Tube	8686	61,908	\$2,000
01-MKX21394XTEND	Auger with X-Tend Hopper	8884	74,234	\$2,000
01-MKX21394XTENDRR	Auger with X-Tend Hopper and Reducer/Reverser	8971	80,493	\$2,000
01-MKX21394XOVER	Auger with X-Over Hopper	9586	74,234	\$2,000

**Complete Bundle Includes: Low Profile Hopper, Hydraulic Hopper Winch, Transport and Work Light Kit**

**Reducer/Reverser Bundles Include 21 Spline CV-PTO (05-A246)**

### MKX<sup>2</sup> 13 x 114 AUGER

01-MKX213114	Auger with Low Profile Hopper	9015	64,533	\$2,000
01-MKX213114S	Auger with Low Profile Hopper and Corn Screen	9026	65,570	\$2,000
01-MKX213114L	Basic Auger with 15' Swing Tube	9251	66,538	\$2,000
01-MKX213114CBH	Complete Bundle with Hydraulic Power Swing	9462	70,711	\$2,000
01-MKX213114CB	Complete Bundle with Electric Power Swing	9452	72,821	\$2,000
01-MKX213114CBHR	Complete Bundle with Hydraulic Power Swing and	9498	72,179	\$2,000
01-MKX213114CBR	Complete Bundle with Electric Power Swing and	9488	74,290	\$2,000
01-MKX213114CBRR	Complete Bundle with Electric Power Swing and	9484	79,080	\$2,000
01-MKX213114CBHL	Complete Bundle with 15' Hydraulic Power Swing	9702	72,716	\$2,000
01-MKX213114CBL	Complete Bundle with 15' Electric Power Swing Tube	9692	74,826	\$2,000
01-MKX213114CBHRL	Complete Bundle with 15' Hydraulic Power Swing	8242	74,185	\$2,000
01-MKX213114CBRL	Complete Bundle with 15' Electric Power Swing Tube	8232	76,295	\$2,000
01-MKX213114XTEND	Auger with X-Tend Hopper	9922	87,685	\$2,000
01-MKX213114XTENDRR	Auger with X-Tend Hopper and Reducer/Reverser	10013	93,944	\$2,000
01-MKX213114XOVER	Auger with X-Over Hopper	10625	87,685	\$2,000

**Complete Bundle Includes: Low Profile Hopper, Hydraulic Hopper Winch, Transport and Work Light Kit**

**Reducer/Reverser Bundles Include 21 Spline CV-PTO (05-A246)**

### OPTIONS

05-A175	Poly Bucket Spout, 49" - 5 section, Fits 13" Augers	21	490	\$49
05-A184	MKX/X100/MKX/X130 Low Profile Hopper Tarp	9	486	\$49
05-A185	13" Corn Screen	33	1,158	\$116
05-A219	CV-PTO 1/2 Shaft For MKX/X13-64/74 Models (21	30	1,372	\$137
05-A220	CV-PTO 1/2 Shaft For MKX/X13-64/74 Models (20	30	1,524	\$152
05-A246	CV-PTO 1/2 Shaft For MKX/X13-84/94/114 Models (21	30	1,590	\$159



Part Number	Description	Weight (lbs)	List Price	Back Freight
05-A247	CV-PTO 1/2 Shaft For MKX13-84/94/114 Models (20	33	\$1,699	\$170
05-A262	MKX 1000 RPM Reducer/Reverser	311	\$6,381	\$638
05-A263	MKX/X130 Reverser Kit	49	\$1,640	\$164
05-A266	MKX/X130 Hydraulic Hopper Lift Kit	75	\$2,521	\$252
05-A271	Additional Remote Control	1	\$432	\$43
05-A283	No Snag Flex Spout, 3 section, Fits 13" Augers	19	\$573	\$57
05-A331	Hopper Weight for Lift Cable	15	\$156	\$16
05-A333	13" Hydraulic Landing Gear Power Swing	320	\$4,070	\$407
05-A334	13" Remote Electric Landing Gear Power Swing	310	\$6,426	\$643
05-A349	1364 Work Light Kit	25	\$907	\$91
05-A351	1374 Work Light Kit	17	\$907	\$91
05-A353	1384 Transport and Work Lights Bundle	61	\$1,442	\$144
05-A355	1394 Transport and Work Lights Bundle	62	\$1,457	\$146
05-A357	13114 Transport and Work Lights Bundle	35	\$1,457	\$146
05-A383	X-Tend Swing Assembly	1740	\$34,490	\$3,449
05-A449	MKX/X13 Spout Head-Hose Ring Replacement	22	\$409	\$41
05-A509RD	MKX2 13-94 Auger Steer Kit *NEW*	427	\$4,714	\$471
05-A510RD	MKX2 13-114 Auger Steer Kit *NEW*	431	\$4,714	\$471
05-A511RD	MKX21384/94/114 Auger Stabilizer *NEW*	275	*call for price	
05-A513RD	MKX2 13" Right Angle Drive 540RPM *NEW*		\$7,007	\$701
05-A514RD	MKX2 13" Right Angle Drive works with Speed Reducer		\$7,133	\$713
05-A516	MKX2/X2/HX2 13" Parts Kit		\$427	\$43
05-A526	MKX2 13" Low-Profile Hopper Assembly	472	\$4,107	\$411

### MKX<sup>2</sup> 13"

14-X101	*Credit for 1364/74 Complete PTO Return	44	\$1,526	
14-X104	*Credit for 1364/74 Tractor Half PTO Return	22	\$760	
14-X108	*Credit for 1384/94/114 Complete PTO Return	72	\$2,834	
14-X109	*Credit for 1384/94/114 Tractor Half PTO Return	28	\$890	
14-X123	*Credit for 13" X-Tend Conversion		\$5,199	

### MKX<sup>2</sup> 16 x 85 AUGER

01-MKX21685	Complete Auger	12579	\$95,699	\$2,000
01-MKX21685XTEND	Auger with X-Tend Hopper	12832	\$115,841	\$2,000

**All 16" augers come as a complete bundles and include: AUGER STEER, pow- erswing, speed reducing gearbox with 20 spline PTO shaft, hydraulic hopper winch, transport and work light bundle**

### MKX<sup>2</sup> 16 x 105

01-MKX216105	Complete Auger	15588	\$112,163	\$2,000
01-MKX216105XTEND	Auger with X-Tend Hopper	15841	\$132,252	\$2,000

**All 16" augers come as a complete bundles and include: AUGER STEER, pow- erswing, speed reducing gearbox with 20 spline PTO shaft, hydraulic hopper winch, transport and work light bundle**

### MKX<sup>2</sup> 16 x 125

01-MKX216125	Complete Auger	17098	\$125,390	\$2,000
01-MKX216125XTEND	Auger with X-Tend Hopper	17352	\$145,045	\$2,000

**All 16" augers come as a complete bundles and include: AUGER STEER, pow- erswing, speed reducing gearbox with 20 spline PTO shaft, hydraulic hopper winch, transport and work light bundle**

### OPTIONS

05-A280	16" Poly Bucket Spout	34	\$703	\$70
05-A281	MKX160 21 Spline Tractor Half PTO	51	\$2,455	\$246
05-A284	No Snag Flex Spout, 3 section, Fits 16" Augers	26	\$737	\$74
05-A305	MKX160 Low Profile Hopper Tarp		\$524	\$52



Part Number	Description	Weight (lbs)	List Price	Back Freight
05-A354	1685 Transport and Work Lights Bundle	30	\$1,435	\$144
05-A356	16105 Transport and Work Lights Bundle	64	\$1,457	\$146
05-A358	16125 Transport and Work Lights Bundle	30	\$1,504	\$150
05-A450	MKX/X16 Spout Head-Hose Ring Replacement	47	\$469	\$47
05-A517	MKX2/X2/HX2 16" Parts Kit		\$247	\$25
05-A518	MKX2 16" Right Angle Drive *NEW*		*call for price	
<b>MKX<sup>2</sup> 16" RETURN/CREDIT</b>				
14-X120	*Credit for 20 Spline Tractor Half PTO Return		\$1,754	

WRX  
TRUCK AUGER



## DRIVE OPTIONS



### MD

#### Motor Drive

The engine mounts crosswise for easy starting from the side of the auger. The motor mount is self-leveling at all auger positions keeping the motor at the correct working angle. The double belt drive with adjustable tension provides better traction and can be easily replaced.



### EMD

#### Electric Motor Drive

The motor mounts firmly to the gearbox and auger tube, keeping it in place and preventing damage. To provide the best possible traction, our models up to 41' have been retrofitted with a double belt drive, while our models of 46' or greater feature a triple belt drive.



### PTO-SD

#### PTO Shaft Drive

The gearbox is connected directly to the driveshaft and offers the convenience and flexibility of using it for left or right hand drive. The PTO-SD comes with a non-separable 60" PTO driveline that extends to 80" and includes a driveline transport saddle to make moving the unit easier.



### Hydraulic Drive

#### Hydraulic Drive

The hydraulic drive auger option uses the tractor's hydraulics to run and has clips to hold hydraulic hoses during use and transport. This drive option provides a smooth, trouble-free operation.

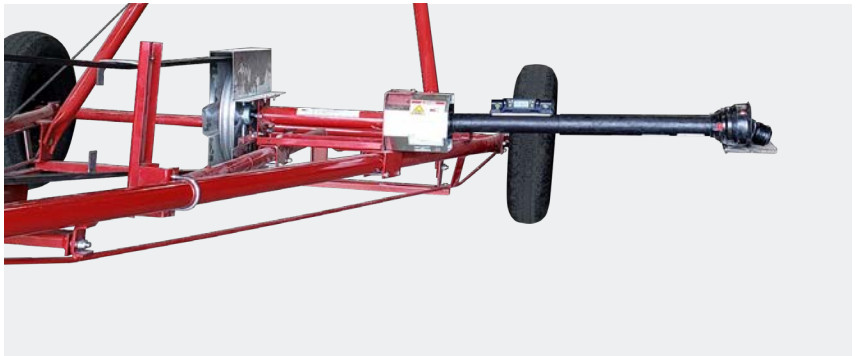

### PTO-BD

#### PTO Belt Drive

The belt drive runs from the gearbox to the jackshaft near the auger wheels - keeping the auger intake away from the tractor, allowing for more working room and longer bin reach. The drive can be positioned to left or right-hand drive and the non-separable 48" PTO can be extended to 68" and is guided by an anti-belt-whip. A driveline saddle holds the drive in place while in transport.

## FEATURES



### Winch

Complete with an automatic brake, the hand winch is sized and geared to match each specific auger - giving you the power to raise and lower your auger manually.

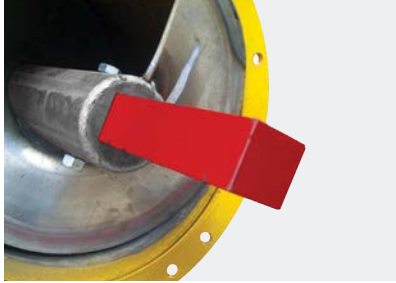

### Flighting

The WRX Series uses one-bolt flight connections to ensure the flighting maintains proper alignment for smooth operation. The 8" models feature a round flighting connection and the 10" models use a square connection.



### Solid Tube Drive Guard

This completely enclosed driveline offers a cleaner look and better protection from the elements. This helps keep your driveline intact for longer, preventing costly repairs. Wood Bearings can still be replaced with split bearings.

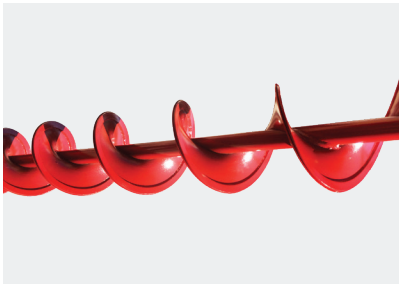

### Wear Edge Technology™

Wear Edge Technology™ extends the life of your flighting, providing an extra layer of steel welded to critical wear points. As a result, flighting lasts longer and needs to be replaced less often – saving you time and money.



### Gearbox

Our gearboxes have forged steel gears with tapered roller bearings running in oil for years of dependable service.



### Undercarriage

Undercarriages of heavy steel tubing are designed for each specific auger length for better balance and stability. Upper lift arms sit back from the axle and quickly tuck away for excellent bin eave clearance. Wide axles provide added stability. High-speed wheels with cast iron hubs and tapered roller bearings come standard.

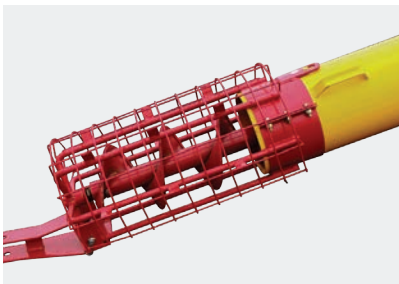

### Intake

The shielded auger intake has a long, one-pin, quick-remove clevis that is easily replaced. Intake flight has welded Wear Edge Technology™ for long life with special low pitch for proven added capacity. Greaseable bushing centers flight reducing vibration and wear.



### Lubricated Upper Drive

Heavy-duty hardened steel sprockets and high-speed roller chain are sized to match auger length and diameter. Lubricated upper drive extends the life of sprockets and drive chain.

**OPTIONS**

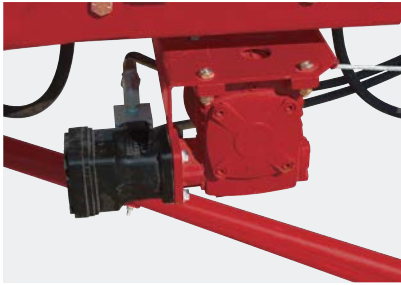

**Hydraulic Winch**

This high capacity hydraulic winch comes complete with an automatic brake and allows you to raise and lower the auger with ease.

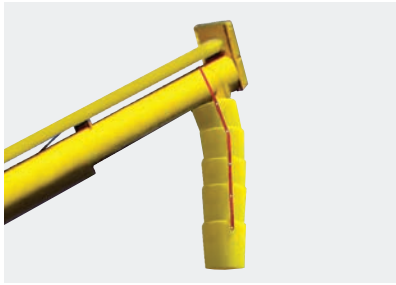

**Flex Spout**

With five bucket sections, the flex spout directs grain flow and reduces spillage, so nothing is wasted. Available in polyethylene.

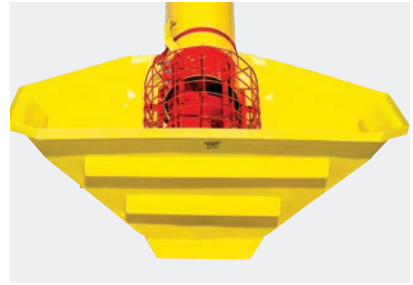

**Poly Hoppers**

Corrosion resistant and lightweight poly hoppers allow for easy grain transfer with minimal spillage, providing a durable and flexible option.



Bin Hopper Dimensions:  
36" Long x 36" Wide

**Steel Intake Hoppers**

The self-leveling steel intake hopper has a tapered transition neck to direct grain from the hopper into the auger, removable access plate for easy cleanout, a tow hitch and stabilizer bar. Optional wheel kit available.



**Wheel Kit**

The Wheel Kit helps move the auger into position easily and works best when using a steel intake hopper.



**Enclosed Collapsible Hopper**

The new enclosed collapsible hopper is a cost effective option that delivers ease of use and maximized efficiency. The hopper mounts over your existing intake cage and releases with the removal of two hitch pins. A removable access door makes for easy cleanout. Comes complete with tow hitch.

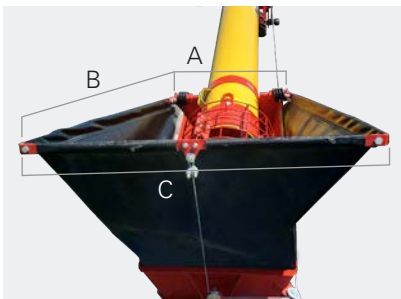

**Enclosed Collapsible Hopper Specifications**

	8"	10"
<b>A</b>	16"	18.5"
<b>B</b>	36.5"	36.5"
<b>C</b>	33"	35.5"

	8"	10"
<b>COLLAPSED HEIGHT</b>	8"	9.5"
<b>TOTAL HEIGHT</b>	26.5"	27.5"



**HEIGHT | REACH | WHEEL | SPECIFICATIONS**

	A	B	C	D	E	F	G	H	I	
	HEIGHT LOWERED	HEIGHT HALFWAY	HEIGHT RAISED	REACH LOWERED	REACH HALFWAY	REACH RAISED	HEIGHT AT LIFTARMS	HEIGHT AT WHEELS	REACH TO LIFTARMS	WHEEL TREAD
31'	8' 1"	14' 9"	20' 9"	12' 7"	11' 4"	9' 4"	8' 9"	12' 5"	9' 7"	70"
31' MD	8' 1"	11' 10"	15' 6"	12' 7"	12' 0"	11' 5"	7' 8"	9' 3"	9' 3"	70"
36'	9' 8"	17' 9"	24' 7"	15' 9"	13' 2"	10' 1"	10' 8"	15' 6"	9' 7"	88"
36' MD	9' 8"	15' 1"	18' 2"	15' 9"	14' 2"	13' 0"	9' 9"	9' 9"	10' 8"	88"
36' BD	10' 11"	17' 8"	24' 6"	14' 8"	13' 1"	10' 9"	11' 1"	15' 3"	10' 5"	88"
41'	10' 4"	20' 3"	29' 1"	17' 9"	15' 11"	12' 9"	11' 6"	16' 4"	12' 9"	88"
41' MD	10' 4"	15' 0"	20' 3"	17' 9"	17' 2"	15' 11"	9' 9"	11' 9"	13' 1"	88"
41' BD	11' 7"	20' 6"	28' 5"	17' 0"	15' 5"	12' 7"	11' 9"	16' 5"	12' 7"	88"
46'	10' 5"	20' 10"	31' 3"	19' 5"	16' 0"	11' 1"	13' 9"	19' 0"	9' 3"	106"
46' BD	11' 5"	22' 6"	31' 5"	17' 9"	15' 10"	12' 8"	14' 5"	19' 9"	11' 8"	106"
51'	10' 5"	24' 8"	35' 0"	22' 1"	19' 7"	16' 5"	14' 3"	19' 0"	18' 0"	106"
51' BD	11' 11"	24' 8"	35' 6"	21' 7"	19' 7"	15' 10"	14' 6"	20' 4"	15' 0"	106"
56'	11' 5"	25' 1"	37' 5"	26' 5"	22' 7"	17' 2"	15' 6"	22' 2"	13' 8"	112"
61'	11' 0"	27' 9"	40' 1"	26' 6"	22' 6"	18' 7"	16' 7"	22' 8"	20' 10"	112"
71'	12' 4"	30' 10"	46' 5"	31' 3"	28' 2"	22' 9"	19' 1"	26' 10"	24' 6"	118"
76'	10' 10"	29' 1"	45' 5"	33' 9"	31' 7"	27' 10"	18' 3"	24' 9"	26' 2"	118"

**HORSEPOWER REQUIREMENTS**

	8"				10"			
	GAS HP	PTO HP	EMD HP	HYD	GAS HP	PTO HP	EMD HP	HYD
31	16	15	5	22 GPM @ 2200 PSI	18 - 20	30	7.5 - 10	22 GPM @ 2200 PSI
36	16 - 18	15	5 - 7.5	22 GPM @ 2200 PSI	22 - 25	35	10 - 15	22 GPM @ 2200 PSI
41	18 - 20	20	5 - 7.5	22 GPM @ 2200 PSI	22 - 25	40	10 - 15	22 GPM @ 2200 PSI
46	—	25	7.5	—	—	—	—	—
51	—	25	10 - 15	—	—	45	15 - 20	—
56	—	30	15	—	—	—	—	—
61	—	35	15 - 20	—	—	55	20	—
71	—	45	20	—	—	60	20 - 25	—
76	—	50	20 - 25	—	—	—	—	—

**Recommended Pulley Sizes:**

- Gas Motor Drives: 4.2" Double Groove Pulley
- Electric Motor Drives: 7.75"
  - < 46' Double Groove, > 46' Triple Groove Pulley

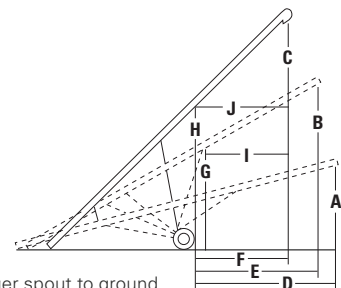

Heights measured from bottom of auger spout to ground.

## WRX8

	WRX8-31	WRX8-36	WRX8-41	WRX8-46	WRX8-51	WRX8-56	WRX8-61	WRX8-71	WRX8-76
TUBING GAUGE	14 GA								
TUBE CONNECTORS	Heavy-duty $\frac{3}{16}$ " Angle Flange								
MAIN FLIGHTING	7" OD x 10 GA Stretched + Welded								
INTAKE FLIGHTING	10 GA Welded with Wear Edge Technology™ Lower Pitch for High Capacity								
FLIGHTING SHAFT	High Strength 1.66" OD x 11 GA Tubing								
DRIVESHAFT	1- $\frac{1}{4}$ " OD x 11 GA Tubing								
DRIVESHAFT BEARINGS	1- $\frac{1}{4}$ " Oil Impregnated Hardwood Bearings								
TUBE TRUSSING	N/A			$\frac{5}{16}$ " Aircraft Cable					
TRACK	High Yield 11 GA Roll Formed								
TRACKSHOE	Single 2- $\frac{3}{4}$ " Steel Roller								
TRANSPORT/UNDERCARRIAGE	2- $\frac{1}{2}$ " x 14 GA A-Frame				3" OD x 11 GA A-Frame				
AXLE	2" x 11 GA Tubing				2- $\frac{1}{2}$ " x $\frac{1}{8}$ " Wall Sq. Tubing				
HUBS & WHEELS	4 Bolt Agricultural Type Hubs, 15" Wheel								
TIRES	15" Agricultural Tires								
LIFT CABLE	$\frac{1}{4}$ " Aircraft Type Galvanized Steel Cable								
TOP DRIVE	#80 Roller Chain & Hardened Steel Sprockets								
TOP DRIVE BEARINGS	1- $\frac{1}{4}$ " Pillow Block								
WINCH	Reduction Geared with Automotive Brake								
GEARBOX	Formed Steel Gears with Tapered Roller Bearings								
CAPACITY - DRY WHEAT OR CORN, AUGER $\frac{1}{2}$ RAISED	Up to 3,000 BPH								

## WRX10

	WRX10-31	WRX10-36	WRX10-41	WRX10-51	WRX10-61	WRX10-71
TUBING GAUGE	12 GA					
TUBE CONNECTORS	Heavy-duty $\frac{3}{16}$ " Angle Flange					
MAIN FLIGHTING	9" OD x 7 GA Stretched + Welded					
INTAKE FLIGHTING	10 GA Welded with Wear Edge Technology™ Lower Pitch for High Capacity					
FLIGHTING SHAFT	High Strength 2" OD x 11 GA Tubing					
DRIVESHAFT	1- $\frac{1}{4}$ " OD x 11 GA Tubing					
DRIVESHAFT BEARINGS	1- $\frac{1}{4}$ " Oil Impregnated Hardwood Bearings					
TUBE TRUSSING	N/A			$\frac{5}{16}$ " Aircraft Cable		
TRACK	High Yield 11 GA Roll Formed					
TRACKSHOE	Single 2- $\frac{3}{4}$ " Steel Roller					
TRANSPORT/UNDERCARRIAGE	2- $\frac{1}{2}$ " x 14 GA A-Frame			3" OD x 11 GA A-Frame		
AXLE	2" x 11 GA Tubing			2- $\frac{1}{2}$ " x $\frac{1}{8}$ " Wall Sq. Tubing		
HUBS & WHEELS	4 Bolt Agricultural Type Hubs, 15" Wheel					
TIRES	15" Agricultural Tires					
LIFT CABLE	$\frac{1}{4}$ " Aircraft Type Galvanized Steel Cable					
TOP DRIVE	#80 Roller Chain & Hardened Steel Sprockets					
TOP DRIVE BEARINGS	1- $\frac{1}{4}$ " Pillow Block					
WINCH	Reduction Geared with Automotive Brake					
GEARBOX	Formed Steel Gears with Tapered Roller Bearings					
CAPACITY - DRY WHEAT OR CORN, AUGER $\frac{1}{2}$ RAISED	Up to 4,800 BPH					

**Disclaimer:** The WRX series auger was proudly designed to handle dry, free-flowing grains up to a maximum density of 65 lb/bu (52 lb/cf). Any usage of this auger outside of this is not authorized by AGI Westfield



Part Number	Description	Weight (lbs)	List Price	Back Freight
-------------	-------------	--------------	------------	--------------

### WRX BASIC AUGERS

*Shipped complete with undercarriage, enclosed driveline, intake with safety sheild, outlet spout, tow hitch, safety shields, winch, and tires with rims. NOTE: Must order a drive kit to complete auger.*

01-WRX0831	8" X 31 Basic Auger	873	\$5,923	\$548
01-WRX0836	8" X 36 Basic Auger	948	\$6,626	\$614
01-WRX0841	8" X 41 Basic Auger	1047	\$7,232	\$670
01-WRX0846	8" X 46 Basic Auger	1312	\$8,001	\$741
01-WRX0851	8" X 51 Basic Auger	1392	\$8,947	\$828
01-WRX0851S	8" X 51 Basic Auger with Corn Screen	1392	\$9,618	\$891
01-WRX0856	8" X 56 Basic Auger	1599	\$10,943	\$1,013
01-WRX0856S	8" X 56 Basic Auger with Corn Screen	1599	\$11,614	\$1,075
01-WRX0861	8" X 61 Basic Auger	1654	\$12,841	\$1,189
01-WRX0861S	8" X 61 Basic Auger with Corn Screen	1654	\$13,513	\$1,251
01-WRX0871	8" X 71 Basic Auger	1868	\$13,917	\$1,289
01-WRX0871S	8" X 71 Basic Auger with Corn Screen	1868	\$14,589	\$1,351
01-WRX0876	8" X 76 Basic Auger	1918	\$14,665	\$1,358
01-WRX0876S	8" X 76 Basic Auger with Corn Screen	1918	\$15,337	\$1,420
01-WRX1031	10" x 31' Basic Auger	1146	\$8,248	\$764
01-WRX1036	10" x 36' Basic Auger	1270	\$9,499	\$880
01-WRX1041	10" x 41' Basic Auger	1406	\$10,831	\$1,003
01-WRX1051	10" x 51' Basic Auger	1805	\$13,518	\$1,252
01-WRX1051S	10" x 51' Basic Auger with Corn Screen	1805	\$14,261	\$1,321
01-WRX1061	10" x 61' Basic Auger	2130	\$15,917	\$1,474
01-WRX1061S	10" x 61' Basic Auger with Corn Screen	2130	\$16,660	\$1,543
01-WRX1071	10" x 71' Basic Auger	2425	\$18,170	\$1,682
01-WRX1071S	10" x 71' Basic Auger with Corn Screen	2425	\$18,913	\$1,751

### ELECTRIC MOTOR

*Shipped complete with tube mounted motor mount, belts, and pulley. LESS electric motor, switches, and motor pulley. Recommended pulley size: 7.75" for 1750 RPM motors.*

05-A418	WRX8/10-31/36/41 Electric Motor Drive	100	\$1,922	\$192
05-A423	WRX8/10-46/51/56/61/71 Electric Motor Drive	104	\$1,922	\$192

### HYDRAULIC DRIVE

*Shipped complete with hydraulic motor mount and hydraulic hoses. Requires a minimum of 20 GPM at 2200 PSI.*

05-A428	WRX80-31/36/41 Hydraulic Drive	100	\$3,524	\$352
05-A422	WRX10-31/36/41 Hydraulic Drive	100	\$3,524	\$352

### PTO/SHAFT DRIVE

*Shipped complete with shielded non-separable 60" PTO driveline and transport saddle.*

05-A429RD	WRX80-31 SD - PTO/Shaft Drive	151	\$2,360	\$236
05-A430RD	WRX80-36 SD - PTO/Shaft Drive	150	\$2,360	\$236
05-A431RD	WRX80-41 SD - PTO/Shaft Drive	151	\$2,360	\$236
05-A432RD	WRX80-46 SD - PTO/Shaft Drive	150	\$2,360	\$236
05-A433RD	WRX80-51 SD - PTO/Shaft Drive	152	\$2,360	\$236
05-A434RD	WRX80-56 SD - PTO/Shaft Drive	150	\$2,360	\$236
05-A435RD	WRX80-61 SD - PTO/Shaft Drive	172	\$2,360	\$236
05-A436RD	WRX80-71 SD - PTO/Shaft Drive	172	\$2,360	\$236
05-A444RD	WRX80-76 SD - PTO/Shaft Drive	189	\$2,360	\$236
05-A419RD	WRX10-31 SD - PTO/Shaft Drive	154	\$2,360	\$236
05-A420RD	WRX10-36 SD - PTO/Shaft Drive	152	\$2,360	\$236
05-A421RD	WRX10-41 SD - PTO/Shaft Drive	155	\$2,360	\$236
05-A424RD	WRX10-51 SD - PTO/Shaft Drive	155	\$2,360	\$236
05-A425RD	WRX10-61 SD - PTO/Shaft Drive	173	\$2,360	\$236
05-A426RD	WRX10-71 SD - PTO/Shaft Drive	176	\$2,360	\$236



Part Number	Description	Weight (lbs)	List Price	Back Freight
<b>PTO/BELT DRIVE KITS</b>				
05-A472RD	WRX80-31 BD - PTO/Belt Drive	319	\$3,368	\$337
05-A460RD	WRX80-36 BD - PTO/Belt Drive	322	\$3,368	\$337
05-A461RD	WRX80-41 BD - PTO/Belt Drive	316	\$3,384	\$338
05-A462RD	WRX80-46 BD - PTO/Belt Drive	334	\$3,384	\$338
05-A463RD	WRX80/10-51 BD - PTO/Belt Drive	332	\$3,384	\$338
05-A473RD	WRX10-31 BD - PTO/Belt Drive	319	\$3,368	\$337
05-A464RD	WRX10-36 BD - PTO/Belt Drive	324	\$3,384	\$338
05-A465RD	WRX10-41 BD - PTO/Belt Drive	322	\$3,384	\$338
05-A463RD	WRX80/10-51 BD - PTO/Belt Drive	332	\$3,384	\$338

**PLAIN MOTOR DRIVE**

*Shipped complete with motor mount, gearbox, belts, and pulleys. Recommended pulley size: 4.2" for gas engines, 7.75" for 1750 RPM electric*

05-A466	WRX8/10-31/41 Plain Motor Drive Kit	320	\$2,883	\$288
05-A467	WRX8/10-36 Plain Motor Drive Kit	321	\$2,883	\$288

**COMPLETE MOTOR**

*Shipped complete with motor mount, battery mount, gas tank mount, gas tank, gearbox, belts, and pulleys. Does not come with battery cables.*

05-A470U	WRX8/10-31/41 Complete Motor Drive Kit	351	\$3,298	\$330
05-A471U	WRX8/10-36 Complete Motor Drive Kit	355	\$3,298	\$330

**8" OPTIONS**

05-A103	Regular Poly Hopper, Yellow, 48" Wide, Fits 6/7/8"	17	\$254	\$25
05-A114	Swivel Arc Kit	72	\$723	\$72
05-A164	Poly Bucket Flex Spout, 36" - 5 section, Fits 8/10"	14	\$274	\$27
05-A250	8" Wheel Kit	69	\$983	\$98
05-A260	8" BIN Hopper for STX <sup>2</sup> /WRX	319	\$1,792	\$179
05-A285	Hopper Tarp fits STX <sup>2</sup> 8/10" Intake Hoppers	6	\$340	\$34
05-A443	Speed Reducer Kit	156	\$1,555	\$155
05-A456	WRX Steel Caster Wheel Kit	53	\$1,374	\$137
05-A468	WRX8/10 Motor Drive Battery Kit	13	\$87	\$9
05-A469U	WRX8/10 Motor Drive Fuel Tank Kit	33	\$337	\$34
05-A481	8" Enclosed Collapsible Hopper	261	\$1,734	\$173
05-A488	8"/10" Reduction Gearbox (2:1)		\$922	\$92
05-A489	8"/10" Reduction Gearbox (3:1)		\$922	\$92

*More WRX options under "Optional Equipment"*

**10" OPTIONS**

05-A104	Big Round Poly Hopper, Yellow 50" Diameter, 20" Deep	31	\$480	\$48
05-A114	Swivel Arc Kit	72	\$723	\$72
05-A164	Poly Bucket Flex Spout, 36" - 5 section, Fits 8/10"	14	\$274	\$27
05-A249	10" BIN Hopper	334	\$1,903	\$190
05-A251	10" Wheel Kit	72	\$1,011	\$101
05-A282	No Snag Flex Spout, 3 section, Fits 10" Augers	8	\$357	\$36
05-A285	Hopper Tarp fits STX <sup>2</sup> 8/10" Intake Hoppers	6	\$340	\$34
05-A443	Speed Reducer Kit	156	\$1,555	\$155
05-A456	WRX Steel Caster Wheel Kit	53	\$1,374	\$137
05-A468	WRX8/10 Motor Drive Battery Kit	13	\$87	\$9
05-A469U	WRX8/10 Motor Drive Fuel Tank Kit	33	\$337	\$34
05-A482	10" Enclosed Collapsible Hopper	274	\$1,842	\$184
05-A488	8"/10" Reduction Gearbox (2:1)		\$922	\$92
05-A489	8"/10" Reduction Gearbox (3:1)		\$922	\$92

*More WRX options under "Optional Equipment"*

# STX<sup>2</sup> SERIES

TRUCK AUGERS



# Built for Durability, Longevity & Capacity

**STX<sup>2</sup> 8** 31' - 51' | up to 3,500 BPH

**STX<sup>2</sup> 10** 31' - 51' | up to 5,500 BPH

AGI Westfield's redesigned truck auger has been engineered to withstand the demands of farming today. The STX<sup>2</sup> was built for durability, longevity and capacity. With the STX<sup>2</sup>, you'll get the job done fast.

## Built for Durability

The STX<sup>2</sup> features 12-gauge tubing on 10" models, a heavy-duty motor mount designed to handle high horsepower, heavy auger engines, giving you the flexibility to use the engine you want.

Like all AGI Westfield augers, the flighting includes Wear Edge Technology™, which provides an extra layer of steel welded to the edge at critical wear points to extend the life of your flighting.

The purpose-built hose routing provides a cleaner, sleeker look and protects the hoses from the elements, along with the powder coat paint which protects and provides a long-lasting durable finish.

Heavy-duty hardened steel sprockets and high-speed roller chain are sized to match auger length and diameter, to help your auger perform at its best. A lubricated upper drive extends the life of sprockets and drive chain.

The 10" models use square, one-bolt flight connections to ensure the flighting maintains proper alignment for smooth operation.

## Designed for High Capacity

The STX<sup>2</sup> uses double banded belts that are molded together as one to transfer maximum power from the engine to the gearboxes to maintain consistent speed when the auger is running. To ensure optimal performance is achieved with longer units, the 10" in 46' and 51' lengths use triple banded belts.

## Developed for Ease-of-Use

AGI Westfield's STX<sup>2</sup> is designed with end users in mind. The self-leveling motor maintains proper tension at all heights, so there is no need to reset the belt tension once the auger is raised into position to provide better traction. Less slippage means you can get the job done faster. The electric clutch with remote allows you to start and stop the auger without shutting down the gas engine drives.

AGI Westfield has redesigned their mover kit to make set up as easy as possible. A breeze to move around the yard thanks to its joystick steering, the Self-Propelled (SP) kit also automatically adjusts the intake height when auger discharge is raised or lowered.

## Low Maintenance

The drive shaft bearings are constructed of durable, oil impregnated hardwood for long, quiet operation and can be easily replaced if needed without disassembling the drive shaft. The bearing brackets are factory jig welded to ensure precise alignment. The chain tensioner on the top drive can be easily adjusted and provides consistent chain drive tension, helping to prolong the life of the chain.

## Convenient – Easy to Transport

The STX<sup>2</sup> features a quick detach tow hitch that can be stored on the auger so it's ready to go when you need it. Moving around the yard is even easier with the optional Self-Propelled mover kit, or standard mover kit.

## Warranty

AGI Westfield is committed to providing quality products. To ensure your STX<sup>2</sup> is ready when you need it, AGI Westfield offers a two year limited warranty.



Geometry

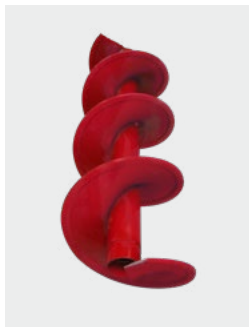

Wear Edge Technology™



Square One-Bolt Connection



Banded Belts

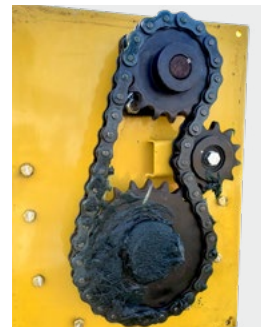

Steel Sprockets

## OPTIONS & ACCESSORIES



### Self-Propelled Heavy-Duty Mover

This Self-Propelled (SP) heavy-duty mover kit features all-wheel drive, hydraulic steering, and rugged all-terrain tires capable of handling tough terrain and yards. This narrow, more compact design allows better access to larger diameter hopper bins and offers drive controls situated closer to the motor to further increase reach under large hoppers. This new mover kit allows for a much sharper turning radius for quicker and easier repositioning. Hydraulic steering comes standard.



### Electric Clutch with Remote Control

The electric clutch with remote control starts and stops the auger without shutting down the gas engine drives and is easy to install.



### Reversing Gearbox

The reversing gearbox allows the auger to be reversed at all angles and includes the linkage and lockout for easy cleanout.

### Steel Hydraulic Lines

Steel hydraulic lines with ORB fittings on the cylinder create a cleaner look and reduces risk of leakage.



### **Poly Hoppers**

Poly hoppers are durable and flexible providing easy grain handling with minimum spillage. Two sizes available: regular poly hopper for 8" augers and a larger "V" hoppers for 10" augers.

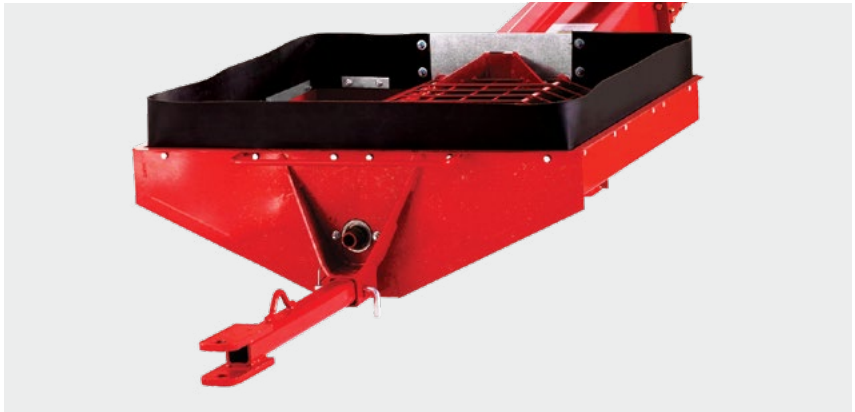

### **Steel Intake Hopper**

The steel intake hopper is self-leveling and has a tapered transition that works with the flighting to direct the flow of grain from the hopper into the auger. The steel intake hopper has a removable access plate for easy cleanout and the flighting features Wear Edge Technology™. The steel intake hopper comes complete with a tow hitch. An optional wheel kit is available and allows the height to be adjusted for positioning.



### **Poly Flex Spout**

The durable poly flex spout features a five-section flex bucket designed to withstand the elements. Poly spouts help direct grain and prevent spillage so nothing is wasted.

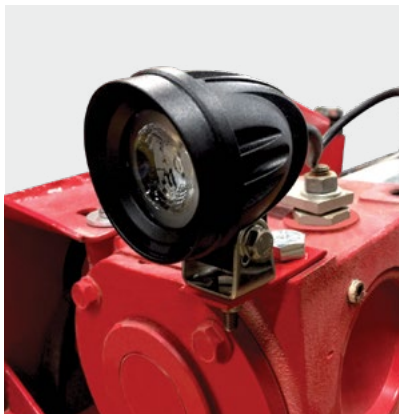

### **LED Working Lights**

LED working lights are mounted to the auger to provide extra lighting in low-light situations, allowing you to work longer when needed.



### **Enclosed Hopper**

The new enclosed hopper is a cost effective option that delivers ease of use and maximized efficiency. The hopper mounts over your existing intake cage and releases with the removal of two hitch pins. A removable access door makes for easy cleanout. Comes complete with tow hitch.



**STX<sup>2</sup>**

	8-31	8-36	8-41	8-46	8-51	10-31	10-36	10-41	10-46	10-51
TUBING GAUGE	14 GA					12 GA				
TUBE CONNECTORS	Heavy-duty 3/16" Angle Flange									
MAIN FLIGHTING	7" OD x 10 GA Stretched + Welded					9" OD x 7 GA Stretched + Welded				
INTAKE FLIGHTING	10 GA Welded with Wear Edge Technology™ Lower Pitch for High Capacity									
FLIGHTING SHAFT	High Strength 1.66" OD x 11 GA Tubing					High Strength 2" OD x 11 GA Tubing				
DRIVE SHAFT	1 1/4" OD x 11 GA Tubing									
DRIVE SHAFT BEARINGS	1 1/4" Oil Impregnated Hardwood Bearings									
TUBE TRUSSING	N/A	N/A	N/A	5/16" Aircraft Cable	5/16" Aircraft Galv. Steel Cable	N/A	N/A	N/A	N/A	5/16" Aircraft Cable
TRACK	High Yield 11 GA Roll Formed									
TRACKSHOE	2 3/4" Steel Roller									
UNDERCARRIAGE	2 1/2" Square Tubing (Upper), 3" Square Tubing (Lower)			3" Square Tubing		2 1/2" Square Tubing (Upper), 3" Square Tubing (Lower)			3" Square Tubing	
AXLE	2 1/2" Square Tubing									
HUBS & WHEELS	4 Bolt Agricultural Type Hubs, 15" Wheel									
TIRES	15" Agricultural Tires									
LIFT CABLE	1/4" Aircraft Type Galvanized Steel Cable									
TOP DRIVE	#80 Roller Chain & Hardened Steel Sprockets									
TOP DRIVE BEARINGS	1 1/4" Cast Flange									
WINCH	Reduction Geared with Automotive Brake									
GEARBOX	Formed Steel Gears with Tapered Roller Bearings									
WHEEL TREAD	96"									
GAS HORSEPOWER	16	16 - 18	18 - 20	22 - 25	25 - 30	25	25 - 30	30 - 35	35 - 38	35 - 38
ELECTRIC HORSEPOWER	5	5 - 7 1/2	5 - 7 1/2	7 1/2	10 - 15	10 - 15	15	15	15	15

**HEIGHT | REACH | WHEEL | SPECIFICATIONS**

	A	B	C	D	E	F	G
<b>8-31</b>	8' 6"	13' 6"	18' 10"	12' 6"	12' 2"	11' 7"	8' 5"
<b>8-36</b>	9'	15' 8"	22' 1"	14' 6"	14' 1"	13' 2"	10'
<b>8-41</b>	8' 4"	16' 4"	24' 6"	16' 9"	16' 5"	15' 9"	12' 1"
<b>8-46</b>	10'	17'	26' 1"	18' 6"	18' 4"	17' 3"	14' 10"
<b>8-51</b>	10' 6"	19' 9"	29'	19' 3"	18' 7"	17' 7"	16' 1"
<b>10-31</b>	8' 6"	13' 6"	18' 10"	12' 6"	12' 2"	11' 7"	8' 7"
<b>10-36</b>	9'	15' 8"	22' 1"	14' 6"	14' 1"	13' 2"	10' 2"
<b>10-41</b>	8' 4"	16' 4"	24' 6"	16' 9"	16' 5"	15' 9"	12' 3"
<b>10-46</b>	10'	17'	26' 1"	18' 6"	18' 4"	17' 3"	14' 11"
<b>10-51</b>	10' 6"	19' 9"	29'	19' 3"	18' 7"	17' 7"	16' 3"

Heights measured from bottom of auger spout to ground.

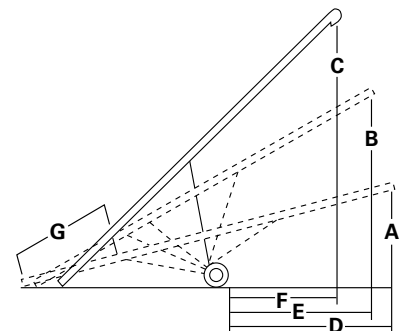



Part Number	Description	Weight (lbs)	List Price	Back Freight
-------------	-------------	--------------	------------	--------------

### STX<sup>2</sup> 8-31 AUGER

01-STX20831	Basic Auger	1475	\$9,023	\$902
01-STX20831SP	Auger with Self Propelled Kit Only	1878	\$15,603	\$1,560
01-STX20831SPCBU	Complete Bundle with Self Propelled Kit	2001	\$19,419	\$1,942

**A complete bundle includes: 1-1/8" Clutch Kit, Battery Mount, Gas Tank, Reversing Gearbox, Light Kit and Battery Cables**

### STX<sup>2</sup> 8-36 AUGER

01-STX20836	Basic Auger	1612	\$9,651	\$965
01-STX20836SP	Auger with Self Propelled Kit Only	2030	\$16,388	\$1,639
01-STX20836SPH	Auger with Heavy Duty Self Propelled Kit Only	2401	\$21,439	\$2,000
01-STX20836SPCBU	Complete Bundle with Self Propelled Kit	2158	\$20,300	\$2,000
01-STX20836SPHCBU	Complete Bundle with Heavy Duty Self Propelled Kit	2527	\$25,255	\$2,000

**A complete bundle includes: 1-1/8" Clutch Kit, Battery Mount, Gas Tank, Reversing Gearbox, Light Kit and Battery Cables**

### STX<sup>2</sup> 8-41 AUGER

01-STX20841	Basic Auger	1716	\$10,239	\$1,024
01-STX20841SP	Auger with Self Propelled Kit Only	2148	\$17,424	\$1,742
01-STX20841SPH	Auger with Heavy Duty Self Propelled Kit Only	2518	\$22,614	\$2,000
01-STX20841SPCBU	Complete Bundle with Self Propelled Kit	2276	\$21,343	\$2,000
01-STX20841SPHCBU	Complete Bundle with Heavy Duty Self Propelled Kit	2644	\$26,432	\$2,000

**A complete bundle includes: 1-1/8" Clutch Kit, Battery Mount, Gas Tank, Reversing Gearbox, Light Kit and Battery Cables**

### STX<sup>2</sup> 8-46 AUGER

01-STX20846	Basic Auger	1889	\$11,065	\$1,106
01-STX20846SP	Auger with Self Propelled Kit Only	2342	\$18,398	\$1,840
01-STX20846SPH	Auger with Heavy Duty Self Propelled Kit Only	2635	\$23,710	\$2,000
01-STX20846SPCBU	Complete Bundle with Self Propelled Kit	2489	\$22,209	\$2,000
01-STX20846SPHCBU	Complete Bundle with Heavy Duty Self Propelled Kit	2761	\$27,661	\$2,000

**A complete bundle includes: 1-1/8" Clutch Kit, Battery Mount, Gas Tank, Reversing Gearbox, Light Kit and Battery Cables**

### STX<sup>2</sup> 8-51 AUGER

01-STX20851	Basic Auger	2025	\$11,908	\$1,191
01-STX20851SP	Auger with Self Propelled Kit Only	2486	\$18,657	\$1,866
01-STX20851SPH	Auger with Heavy Duty Self Propelled Kit Only	2765	\$24,004	\$2,000
01-STX20851SPCBU	Complete Bundle with Self Propelled Kit	2633	\$22,472	\$2,000
01-STX20851SPHCBU	Complete Bundle with Heavy Duty Self Propelled Kit	2896	\$27,823	\$2,000

**A complete bundle includes: 1-1/8" Clutch Kit, Battery Mount, Gas Tank, Reversing Gearbox, Light Kit and Battery Cables**

### OPTIONS

10-28109	BATTERY CABLE (Set of Two)	2	\$120	\$12
05-A103	Regular Poly Hopper, Yellow, 48" Wide, Fits 6/7/8"	17	\$254	\$25
05-A164	Poly Bucket Flex Spout, 36" - 5 section, Fits 8/10" Augers	14	\$274	\$27
05-A224	Electric Clutch Kit 1-1/8" Shaft Size	19	\$2,185	\$219
05-A225	Electric Clutch Kit 1" Shaft Size	19	\$2,185	\$219
05-A250	8" Wheel Kit	69	\$983	\$98
05-A260	8" BIN Hopper for STX <sup>2</sup> /WRX	319	\$1,792	\$179
05-A285	Hopper Tarp fits STX <sup>2</sup> 8/10" Intake Hoppers	6	\$340	\$34
05-A391	STX 36/41/46/51 Reversible Gearbox Kit	63	\$1,547	\$155
05-A414	Electric Clutch Kit 1-1/8" Triple Grove (2019)	35	\$4,479	\$448
05-A415U	STX <sup>2</sup> Gas Tank Package, 42L with Hose (US)	36	\$329	\$33
05-A437	STX <sup>2</sup> 08/1036 Enclosed Belt Guard Kit	19	\$173	\$17



Part Number	Description	Weight (lbs)	List Price	Back Freight
05-A438	STX <sup>2</sup> 08/1041 Enclosed Belt Guard Kit	23	\$190	\$19
05-A439	STX <sup>2</sup> 08/1046 Enclosed Belt Guard Kit	26	\$216	\$22
05-A440	STX <sup>2</sup> 08/1051 Enclosed Belt Guard Kit	27	\$256	\$26
05-A481	8" Enclosed Collapsible Hopper	261	\$1,734	\$173
05-A519	STX46/51 LED Light Kit	6	\$845	\$85
05-A521	STX36/41 LED Light Kit	6	\$845	\$85

### STX<sup>2</sup> 10-31 AUGER

01-STX21031	Basic Auger	1714	\$11,304	\$1,130
01-STX21031SP	Auger with Self Propelled Kit Only	2126	\$17,679	\$1,768
01-STX21031SPCUBU	Complete Bundle with Self Propelled Kit	2249	\$21,594	\$2,159

*A complete bundle includes: 1-1/8" Clutch Kit, Battery Mount, Gas Tank, Reversing Gearbox, Light Kit and Battery Cables*

### STX<sup>2</sup> 10-36 AUGER

01-STX21036	Basic Auger	1867	\$12,530	\$1,253
01-STX21036SP	Auger with Self Propelled Kit Only	2288	\$18,322	\$1,832
01-STX21036SPH	Auger with Heavy Duty Self Propelled Kit Only	2650	\$23,635	\$2,363
01-STX21036SPCUBU	Complete Bundle with Self Propelled Kit	2416	\$22,141	\$2,214
01-STX21036SPHCUBU	Complete Bundle with Heavy Duty Self Propelled Kit	2780	\$27,581	\$2,758

*A complete bundle includes: 1-1/8" Clutch Kit, Battery Mount, Gas Tank, Reversing Gearbox, Light Kit and Battery Cables*

### STX<sup>2</sup> 10-41 AUGER

01-STX21041	Basic Auger	2004	\$13,738	\$1,374
01-STX21041SP	Auger with Self Propelled Kit Only	2440	\$18,908	\$1,891
01-STX21041SPH	Auger with Heavy Duty Self Propelled Kit Only	2799	\$24,411	\$2,441
01-STX21041SPCUBU	Complete Bundle with Self Propelled Kit	2568	\$22,831	\$2,283
01-STX21041SPHCUBU	Complete Bundle with Heavy Duty Self Propelled Kit	2929	\$28,246	\$2,825

*A complete bundle includes: 1-1/8" Clutch Kit, Battery Mount, Gas Tank, Reversing Gearbox, Light Kit and Battery Cables*

### STX<sup>2</sup> 10-46 AUGER

01-STX21046	Basic Auger	2195	\$15,552	\$1,555
01-STX21046SP	Auger with Self Propelled Kit Only	2647	\$19,945	\$1,995
01-STX21046SPH	Auger with Heavy Duty Self Propelled Kit Only	2926	\$25,561	\$2,556
01-STX21046SPCUBU	Complete Bundle with Self Propelled Kit	2804	\$25,612	\$2,561
01-STX21046SPHCUBU	Complete Bundle with Heavy Duty Self Propelled Kit	3055	\$31,227	\$3,123

*A complete bundle includes: 1-1/8" Clutch Kit, Battery Mount, Gas Tank, Reversing Gearbox, Light Kit and Battery Cables*

### STX<sup>2</sup> 10-51 AUGER

01-STX21051	Basic Auger	2408	\$16,394	\$1,639
01-STX21051SP	Auger with Self Propelled Kit Only	2871	\$21,118	\$2,112
01-STX21051SPH	Auger with Heavy Duty Self Propelled Kit Only	3132	\$26,798	\$2,680
01-STX21051SPCUBU	Complete Bundle with Self Propelled Kit	3028	\$26,784	\$2,678
01-STX21051SPHCUBU	Complete Bundle with Heavy Duty Self Propelled Kit	3261	\$32,618	\$3,262

*A complete bundle includes: 1-1/8" Clutch Kit, Battery Mount, Gas Tank, Reversing Gearbox, Light Kit and Battery Cables*

### OPTIONS

10-28109	BATTERY CABLE (Set of Two)	2	\$120	\$12
05-A104	Big Round Poly Hopper, Yellow 50" Diameter, 20" Deep	31	\$480	\$48
05-A164	Poly Bucket Flex Spout, 36" - 5 section, Fits 8/10" Augers	14	\$274	\$27
05-A224	Electric Clutch Kit 1-1/8" Shaft Size	19	\$2,185	\$219
05-A225	Electric Clutch Kit 1" Shaft Size	19	\$2,185	\$219



Part Number	Description	Weight (lbs)	List Price	Back Freight
05-A249	10" BIN Hopper	334	\$1,903	\$190
05-A251	10" Wheel Kit	72	\$1,011	\$101
05-A282	No Snag Flex Spout, 3 section, Fits 10" Augers	8	\$357	\$36
05-A285	Hopper Tarp fits STX <sup>2</sup> 8/10" Intake Hoppers	6	\$340	\$34
05-A391	STX 36/41/46/51 Reversible Gearbox Kit	63	\$1,547	\$155
05-A414	Electric Clutch Kit 1-1/8" Triple Groove (2019)	35	\$4,479	\$448
05-A415U	STX <sup>2</sup> Gas Tank Package, 42L with Hose (US)	36	\$329	\$33
05-A437	STX <sup>2</sup> 08/1036 Enclosed Belt Guard Kit	19	\$173	\$17
05-A438	STX <sup>2</sup> 08/1041 Enclosed Belt Guard Kit	23	\$190	\$19
05-A439	STX <sup>2</sup> 08/1046 Enclosed Belt Guard Kit	26	\$216	\$22
05-A440	STX <sup>2</sup> 08/1051 Enclosed Belt Guard Kit	27	\$256	\$26
05-A482	10" Enclosed Collapsible Hopper	274	\$1,842	\$184
05-A519	STX46/51 LED Light Kit	6	\$845	\$85
05-A520RD	Throttle Controls Kit	12	\$601	\$60

# UTX

## U-TROUGH AUGER



Built to Out-Perform

# It's not an ordinary auger... it's a Westfield

Since 1951, AGI Westfield has been dedicated to bringing the highest level of manufacturing quality and expertise to the agricultural industry. Through this commitment to innovation, AGI Westfield introduces the UTX U-Trough Auger.

The UTX Auger brings together innovations like Wear Edge Technology™ to extend the life of the flighting and powder coat paint to protect against and repel rust. AGI Westfield's UTX Auger features a completely enclosed driveline guard providing a cleaner, sleeker look while protecting your auger from the elements. Steel hydraulic lines with ORB fittings have been added to the new Self-Propelled Mover Kit to create a cleaner look while reducing the chance of leakage. We know farmers are looking for labor-saving, cost-effective upgrades to help make their work easier. AGI Westfield recognizes these needs and has added features like a removable tow bar to make connecting and detaching from the hitch easier than ever and a hydraulic winch to raise and lower the auger with ease and precision. AGI Westfield has also added an easily adjustable chain tensioner to help maintain the consistent chain drive tension. The top drive comes sealed with a durable cover and inside you'll find grease-lubricated, forged steel sprockets and a heavy-duty chain, designed to match your auger's capacity. For long, quiet operation, the driveshaft and bearings are constructed of durable oil impregnated hardwood and can be easily replaced without disassembling the driveshaft.

To further improve performance, AGI Westfield uses square one-bolt flight connections providing positive torque transfer. All UTX models come standard with triple banded belts to better maintain speed by providing improved tension with less slippage. AGI Westfield's UTX Truck Auger is a high performance, high capacity auger that's ready to help make your job easier and faster.



### Reversing Gearbox

Comes with shifting linkage and lockout, allowing the operator to safely reverse the auger at all angles.



### Self-Propelled Heavy-Duty Mover

Complete with all-wheel drive, standard hydraulic steering, and rugged all-terrain tires capable of handling tough terrain, this compact mover kit gives better access to large diameter hopper bins and a sharper turning radius.



Solid Tube Guard



Triple Banded Belts



Adjustable Chain Tensioner



Steel Hydraulic Lines



### Collapsing Spring Loaded Hopper Extension

Quickly and easily fit under your lowest and hardest to reach bin unloads and hopper bins with this hopper extension.



### Powerful Gas Motor

The UTX comes complete with a powerful Vanguard gas motor and large 44-liter gas tank to help you work longer.

Heights measured from bottom of auger spout to ground.

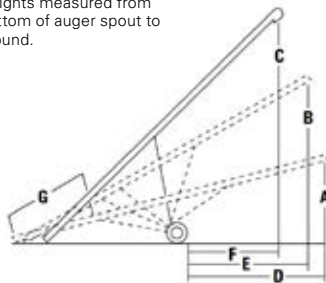

A	9' 2"
B	13' 9"
C	18' 4"
D	14' 10"
E	15'
F	14' 7"
G	11'



### Work Lights

LED work lights provide enhanced lighting conditions when the sun has gone down.



### Triple-Groove Electric Clutch

Start and stop the auger without shutting down the gas engine drives.

### SPECIFICATIONS

TROUGH GAUGE	12 GA
TROUGH CONNECTORS	¼" Flange
MAIN FLIGHTING	10" OD x 7 GA stretched + welded
INTAKE FLIGHTING	10" OD x 7 GA welded with Wear Edge Technology™
FLIGHTING SHAFT	2" OD x 0.120" Wall tubing
DRIVESHAFT	1 ½" OD x 10 GA tubing
DRIVESHAFT BEARINGS	1 ½" Oil impregnated hardwood bearings
TRACK	High yield 11 GA roll formed
TRACK SHOE	2 ¾" Steel roller
UNDERCARRIAGE	3" Square tubing
AXLES	2 ½" Square tubing
HUB & WHEELS	4 Bolt agricultural type hubs, 15" wheel
LIFT CABLE	¼" Aircraft type galvanized steel cable
TIRES	15" Agricultural tires
BELT SIZE	3B270
TOP DRIVE	#80 Roller chain & hardened steel sprockets
TOP DRIVE BEARINGS	1 ¼" Pillow block
WINCH	Reduction gear with automatic brake
GEARBOX	Formed steel gears with tapered roller bearings
WHEEL TREAD	96"
GAS HORSEPOWER	40
CAPACITY	7,000 - 9,000 BPH

**Disclaimer:** The UTX series auger was proudly designed to handle dry, free-flowing grains up to a maximum density of 65 lb/bu (52 lb/cf). Any usage of this auger outside of this is not authorized by AGI

	DISCHARGE CLEARANCE DIMENSIONS	TRANSPORT DIMENSIONS
MIN	9' 6"	LENGTH 45' 6"
MAX	18' 1"	WIDTH 8"
HEIGHT	10' 6"	HEIGHT 10' 6"

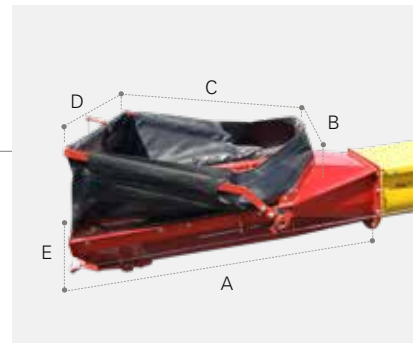

WEIGHT		HOPPER DIMENSIONS	
HITCH WEIGHT (W/ ENGINE)	472 LBS	A - HOPPER LENGTH	37 ½"
TOTAL WEIGHT (W/ ENGINE)	3,058 LBS	B - HOPPER WIDTH	29 ¾"
HEIGHT	10' 6"	C - CANVAS OPENING LENGTH	34 ⅛"
		D - CANVAS OPENING WIDTH	37 ¾"
		E - COLLAPSED HEIGHT	15 ⅝"

# AGI WESTFIELD

Part Number	Description	Weight (lbs)	List Price	Back Freight
<b>UTX 44 AUGER</b>				
01-WFUTX44SPHCBHV	U-Trough Auger with Vanguard 40 HP EFI Motor	3572	\$49,824	\$2,000



# WR & W SERIES

TRUCK AUGERS



## FEATURES



### Winch

Hand winch with automatic brake is sized and geared to match the auger. The strong 1/4" galvanized aircraft type cable can handle up to 7,000 lbs. of pressure.



### Flighting

Wear Edge Technology™ is added to the flighting. This means flighting is mounted and stretched on the flight shaft with hydraulic power and then welded in place for smoother running and longer life. All stretched and welded flight connections are timed for smooth grain flow.



### Rollertrack Shoe

A roll-formed track under the auger tube provides excellent rigid support. Augers 46' and up have heavy-duty cable trussing for extra support and positive tube alignment.



### Driveshaft Bearings

Driveshaft bearings constructed of durable oil-impregnated hard-wood, for long, quiet operation can be easily replaced if needed with no disassembly of driveshaft. Bearing brackets are factory jig-welded for precise alignment.



### Gear Boxes

Gear boxes have forged steel gears with tapered roller bearings running in oil for years of dependable service and can be flipped for right or left hand PTO drive.



### Intake

The shielded auger intake has a long, one-pin, quick-remove clevis that is easily replaced. Intake flight has welded Wear Edge™ for long life with special low pitch for proven added capacity. Greaseable bushing centers flight reducing vibration and wear.



### Lubricated Upper Drive

Heavy-duty hardened steel sprockets and high speed roller chain are sized to match auger length and diameter. Lubricated upper drive extends the life of sprockets and drive chain. Standard on all models.



### Undercarriage

Undercarriages of heavy steel tubing are designed for each specific auger length for better balance and stability. Added cross bracing is used on larger models. Upper lift arms sit back from the axle and quickly tuck away for excellent bin eave clearance. Wide axles provide added stability. High speed wheels with cast iron hubs and tapered roller bearings are standard.

# Drive Options

## MD

### Motor Drive

The engine mounts crosswise for easy starting from the side of the auger. The motor mount (for either gas engine or electric motor) is self-leveling at all auger positions keeping the motor at the correct working angle. Double belt drive with adjustable tension provides better traction and can be easily replaced. The motor drive does not have any gear boxes, so there are less moving parts. This means less time and money are spent on maintenance and repairs.



## EMD

### Electric Motor Drive

The electric motor is available for all models. The motor mounts firmly to the gear box and auger tube, keeping it in place and preventing damage. A double or triple belt drive (depending on model), provides better traction. Positive belt tension can be achieved by using the threaded adjustment, ensuring the auger is performing at maximum capacity.

W 13 available in this drive option



## PTO-SD

### PTO Shaft Drive

The gear box is connected directly to the drive shaft and offers the convenience and flexibility of using it for left or right hand drive. The PTO-SD comes with a non-separable 60" PTO driveline that extends to 80" and includes a driveline transport saddle.

W 13 available in this drive option



## PTO-BD

### PTO Belt Drive

The belt drive runs from the gear box to the jack shaft near the auger wheels - keeping the auger intake away from the tractor. This allows for more working room and longer bin reach. The drive can be positioned to left or right hand drive and the non-separable 48" PTO can be extended to 68" and is guided by an anti-belt-whip. A driveline saddle holds the drive in place when the auger is in transport.



**OPTIONAL FEATURES**

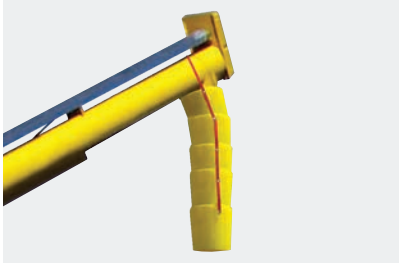

**Flex Spout**

With five bucket sections, the flex spout directs grain flow and reduces spillage. Available in polythylene.



**Swivel Arc Kits**

The Swivel Arc Kit allows the auger to move around circular bin setups.

Available only on the WR 6



**Poly Hoppers**

Poly hoppers are durable and flexible providing easy grain handling with minimum spillage.

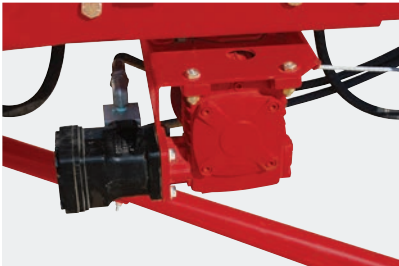

**Hydraulic Winch**

High capacity winch with automatic brake allows the user to raise and lower the auger easily with less effort than a hand winch.

W 13-51/61/71 come with hydraulic lift  
W 13-31/36/41 come standard with hand winch

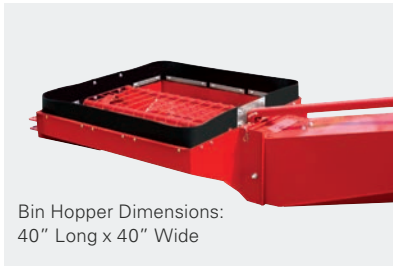

Bin Hopper Dimensions:  
40" Long x 40" Wide

**Steel Intake Hoppers**

The self-leveling steel intake hopper has a tapered transition neck to direct grain from the hopper into the auger, removable access plate for easy clean-out, a tow hitch and stabilizer bar. Optional wheel kit available.

Available only on the W 13



**Wheel Kit**

The wheel kit helps move the auger into position easily and works best when using a steel intake hopper.

Available only on the W 13



**Enclosed Collapsible Hopper**

The new enclosed collapsible hopper is a cost effective option that delivers ease of use and maximized efficiency. The hopper mounts over your existing intake cage and releases with the removal of two hitch pins. A removable access door makes for easy clean-out. Comes complete with tow hitch.

Available only on the W 13

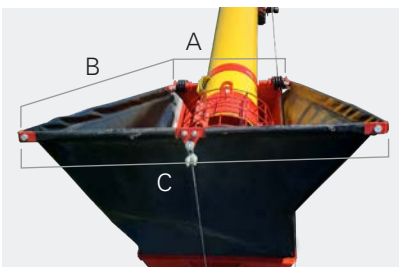

**SPECIFICATIONS**

	13"
<b>A</b>	20.75"
<b>B</b>	36.5"
<b>C</b>	37.5"

	13"
<b>COLLAPSED HEIGHT</b>	11"
<b>TOTAL HEIGHT</b>	29"

# WR+W

## HEIGHT | REACH | WHEEL | SPECIFICATIONS

WR	A HEIGHT LOWERED	B HEIGHT HALFWAY	C HEIGHT RAISED	D REACH LOWERED	E REACH HALFWAY	F REACH RAISED	G HEIGHT AT LIFTARMS	H HEIGHT AT WHEELS	I REACH TO LIFTARMS	WHEEL TREAD
26'	6' 5"	12' 8"	17' 11"	10' 9"	9' 5"	7' 3"	7' 9"	11' 4"	6' 10"	68"
31'	7' 8"	15' 1"	21' 6"	13' 9"	12' 0"	9' 3"	8' 10"	12' 10"	7' 8"	70"
36'	9' 0"	17' 4"	24' 10"	16' 3"	14' 3"	11' 2"	10' 0"	14' 4"	8' 11"	82"
41'	9' 7"	20' 2"	28' 7"	18' 8"	16' 4"	12' 8"	11' 6"	16' 4"	10' 2"	88"
51'	11' 11"	25' 0"	35' 0"	23' 1"	20' 2"	15' 10"	14' 2"	19' 11"	12' 10"	94"
61'	11' 8"	28' 4"	41' 0"	27' 4"	24' 4"	19' 0"	17' 2"	24' 3"	16' 2"	112"
<b>W</b>										
31'	7' 7"	13' 9"	19' 3"	13'	11' 9"	9' 8"	9'	12' 5"	8'	106"
36'	7' 10"	15' 4"	22' 1"	15'	14' 2"	12' 11"	9' 6"	12' 10"	11' 1"	106"
41'	10' 0"	19' 9"	28' 3"	16' 5"	14' 5"	11' 3"	—	—	—	94"
51'	10' 9"	21' 10"	35' 5"	22' 4"	20' 2"	15' 3"	—	—	—	112"
61'	11' 7"	25' 8"	41' 1"	27' 5"	24' 10"	20' 0"	—	—	—	118"
71'	12' 11"	30' 10"	47' 0"	32' 3"	29' 5"	23' 1"	—	—	—	124"

### Recommended Pulley Sizes:

- Gas Motor Drives: 4.2" Double Groove Pulley
- Electric Motor Drives: 7.75"  
< 41' Double Groove, > 41' Triple Groove Pulley

## HORSEPOWER REQUIREMENTS

	6"			13"	
	GAS HP	PTO HP	ELEC. HP	PTO HP	ELEC. HP
26'	10	—	3	—	—
31'	10	—	3	40	20
36'	12	—	3	40 - 50	20 - 25
41'	12	—	3	50	25
51'	—	20	5	70	—
61'	—	25	7.5	80	—
71'	—	—	—	90	—

**Disclaimer:** The WR+W series auger was proudly designed to handle dry, free-flowing grains up to a maximum density of 65 lb/bu (52 lb/cf). Any usage of this auger outside of this is not authorized by AGI Westfield

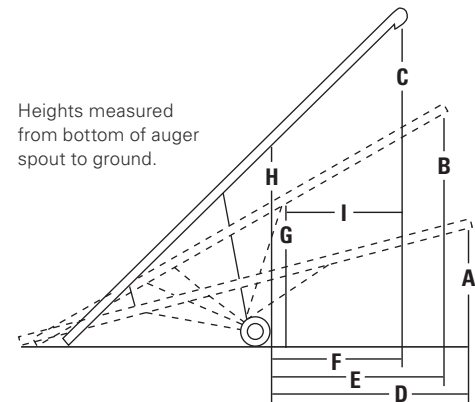



Part Number	Description	Weight (lbs)	List Price	Back Freight
<b>WR 6 x 26 AUGER</b>				
01-0626MD	WR60 - 26 Motor Drive	605	\$5,446	\$545
01-0626EMD	WR60 - 26 Electric Motor Drive	545	\$5,851	\$585
<b>WR 6 x 31 AUGER</b>				
01-0631MD	WR60 - 31 Motor Drive	660	\$6,012	\$601
01-0631EMD	WR60 - 31 Electric Motor Drive	660	\$6,424	\$642
01-0631SD	WR60 - 31 Shaft Drive	660	\$7,427	\$743
05-S40	WR60 x 31' PTO-SD Drive Kit	70	\$1,635	\$164
<b>WR 6 x 36 AUGER</b>				
01-0636MD	WR60 - 36 Motor Drive	740	\$6,655	\$665
01-0636EMD	WR60 - 36 Electric Motor Drive	735	\$7,044	\$704
01-0636BD	WR60 - 36 Belt Drive	825	\$8,218	\$822
01-0636SD	WR60 - 36 Shaft Drive	735	\$7,782	\$778
05-B30	WR60 x 36' PTO-BD Drive Kit	154	\$2,193	\$219
05-S41	WR60 x 36' PTO-SD Drive Kit	75	\$1,704	\$170
<b>WR 6 x 41 AUGER</b>				
01-0641MD	WR60 - 41 Motor Drive	820	\$7,142	\$714
01-0641EMD	WR60 - 41 Electric Motor Drive	815	\$7,519	\$752
01-0641BD	WR60 - 41 Belt Drive	905	\$8,702	\$870
01-0641SD	WR60 - 41 Shaft Drive	765	\$8,385	\$839
05-B31	WR60 x 41' PTO-BD Drive Kit	154	\$2,216	\$222
05-S42	WR60 x 41' PTO-SD Drive Kit	88	\$1,773	\$177
<b>WR 6 x 51 AUGER</b>				
01-0651EMD	WR60 - 51 Electric Motor Drive	1000	\$9,535	\$954
01-0651SD	WR60 - 51 Shaft Drive	1015	\$10,377	\$1,038
<b>WR 6 x 61 AUGER</b>				
01-0661EMD	WR60 - 61 Electric Motor Drive	1400	\$12,437	\$1,244
01-0661SD	WR60 - 61 Shaft Drive	1410	\$12,814	\$1,281
<b>OPTIONS</b>				
05-A103	Regular Poly Hopper, Yellow, 48" Wide, Fits 6/7/8"	17	\$254	\$25
05-A161	WR Shielded PTO Driveline, 48" Closed	28	\$803	\$80
05-A162	WR Shielded PTO Driveline, 60" Closed	32	\$852	\$85
05-A163	Poly Bucket Flex Spout, 36" - 5 section, Fits 6/7" Augers	10	\$254	\$25
05-A248	8" BIN Hopper for WR	308	\$1,834	\$183
05-A441	WR60 Max Reduction Socket Kit	4	\$54	\$5
05-M21	WR60 Motor Drive Kit Fits 26', 31', 36', 41'	100	\$1,594	\$159
<b>W 13 x 31 AUGER</b>				
01-1331EMD	W130 - 31 Electric Motor Drive	1787	\$17,144	\$1,714
01-1331SD	W130 - 31 - PTO Shaft Drive	1796	\$17,561	\$1,756
<b>W 13 x 36 AUGER</b>				
01-1336EMD	W130 - 36 Electric Motor Drive	1920	\$18,141	\$1,814
01-1336SD	W130 - 36 - PTO Shaft Drive	1951	\$18,555	\$1,856
<b>W 13 x 41 AUGER</b>				
01-1341EMD	W130 - 41 Electric Motor Drive	2210	\$19,139	\$1,914
01-1341SD	W130 - 41 - PTO Shaft Drive	2160	\$19,557	\$1,956



Part Number	Description	Weight (lbs)	List Price	Back Freight
<b>W 13 x 51 AUGER</b>				
01-1351SD	W130 - 51 - PTO Shaft Drive	2975	\$31,749	\$2,000
<b>W 13 x 61 AUGER</b>				
01-1361SD	W130 - 61 - PTO Shaft Drive	3440	\$35,170	\$2,000
<b>W 13 x 71 AUGER</b>				
01-1371SD	W130 - 71 - PTO Shaft Drive	3935	\$39,422	\$2,000
<b>OPTIONS</b>				
05-A175	Poly Bucket Spout, 49" - 5 section, Fits 13" Augers	21	\$490	\$49
05-A254	13" BIN Hopper	488	\$2,214	\$221
05-A255	13" Wheel Kit	78	\$1,059	\$106
05-A283	No Snag Flex Spout, 3 section, Fits 13" Augers	19	\$573	\$57
05-A483	13" Enclosed Collapsible Hopper	293	\$2,145	\$214

# UTILITY AUGERS

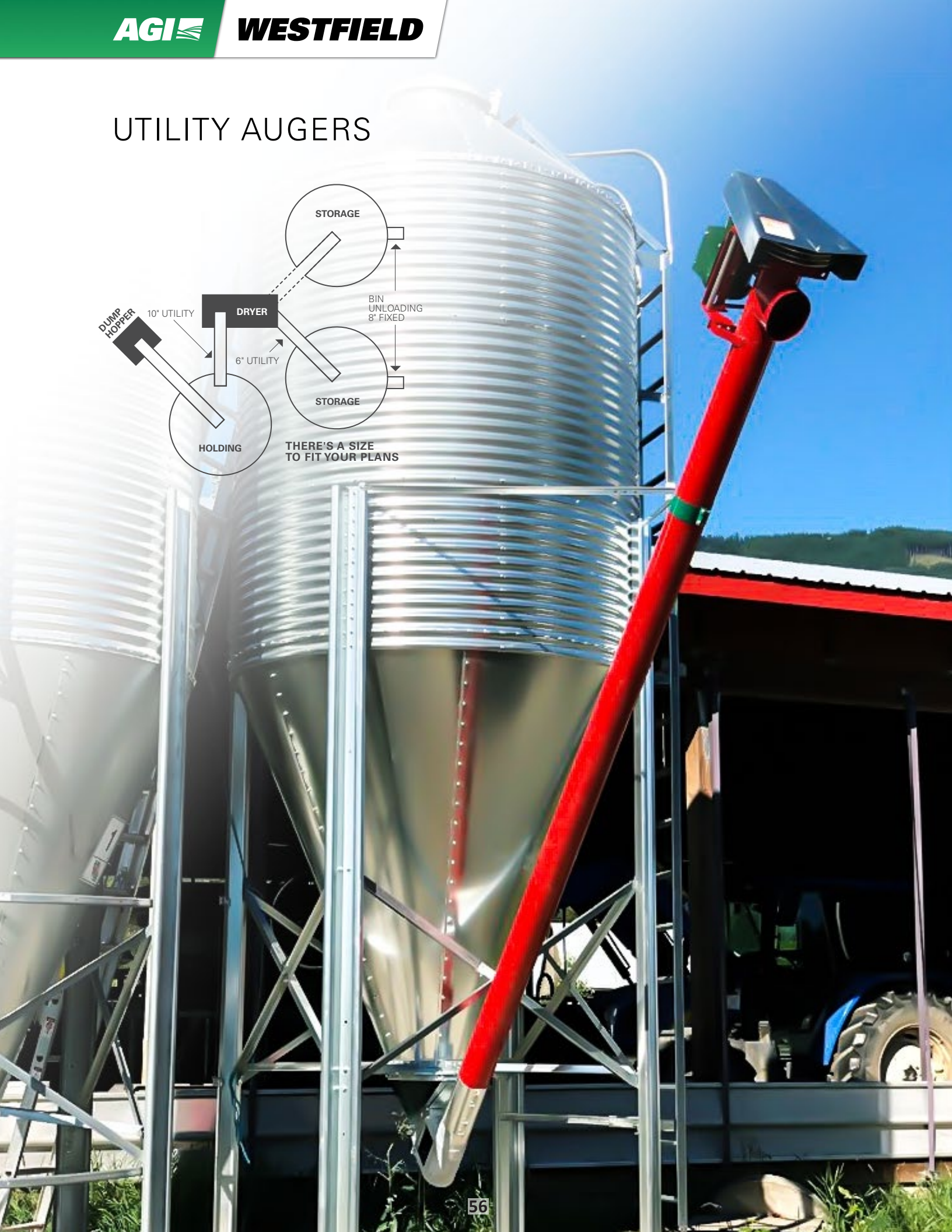
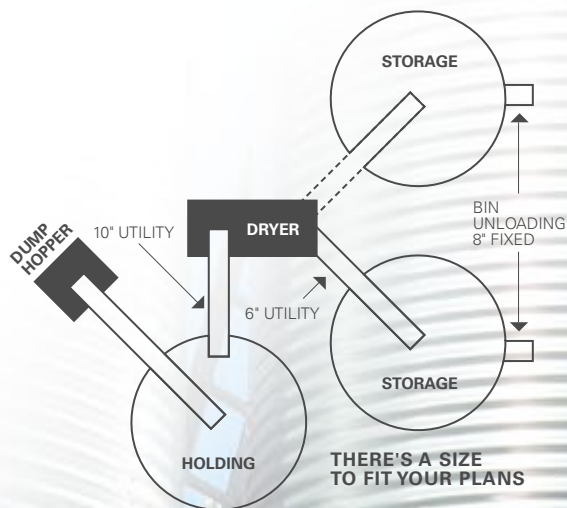



# AGI Westfield Utility Augers

- For permanent or semi-permanent auger installations
- Utility augers in 4", 6", 8", 10" and 13" diameters in various lengths
- Can be used at grain bins or bulk tanks
- Electric motor, pulley, and switches not supplied

## 4"

**11' BASIC AUGER  
5' & 10' EXTENSION**



Portable 4" auger, adjustable motor mount, shielded single "A" belt and pulley, and pre-lubricated top end bearing.



Handy swivel mount bracket for quick mounting to truck box, wagon or feed bin.

## 6" | 8" | 10"

**16' BASIC AUGER  
5', 10' or 15' EXTENSION**



Upper drive has heavy-duty flange ball bearing and adjustable motor mount with double "B" belts and pulley (triple belts on 13" models).



Optional bolt-on flight support bushing with grease fitting (standard on 13" models).

## 13"

**21' BASIC AUGER  
5', 10' or 15' EXTENSION**



Optional bolt-on tube clamps for attaching support bracing.



Optional handy steel hopper with flight support bearing. Also available with hinged lid for 6" to 10" models.

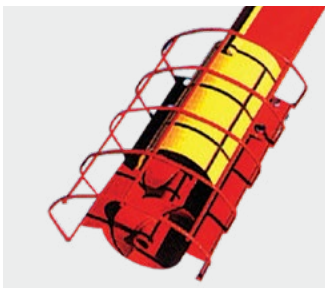

Shielded intake assembly bolts to basic drive section or extension, shown with optional adjustable feed control.



**OTHER OPTIONS** Flex Spout | Poly Hopper | Triple Groove Pulley (comes with 3-belts for long 10" augers)

## SPECIFICATIONS

	4"	6"	8"	10"	13"
RECOMMENDED PULLEY SIZE FOR 1,750 RPM MOTORS	1A 2" – 2 ¼"	2B 3½" – 4"	2B 3¼" – 3½"	2B 3¼" – 3½"	3B 3¼" – 3½"
FLIGHT SPEED	440" – 490"	480" – 550"	445" – 480"	380" – 410"	355" – 380"
AUGER PULLEY SUPPLIED	1A 8"	2B 12.7"	2B 12.7"	2B 15"	3B 16"
BELT(S) SUPPLIED	1 – A33	2 – B48	2 – B 51	2 – B 62	3 – B 67
EXTENSIONS AVAILABLE	5', 10'	5', 10', 15'	5', 10', 15'	5', 10', 15'	5', 10', 20'
TUBE GAUGE	16 GA	16 GA	14 GA	12 GA	12 GA
FLIGHT GAUGE	13 GA	12 GA	10 GA	7 GA	¼"

Note: For intermittent feed, a slightly smaller pulley will allow easier startup under load.

## HORSEPOWER REQUIREMENTS

	4"	6"	8"	10"	13"
11'	¾	—	—	—	—
16' – 21'	¾ – 1	1½ – 2	3	3 – 5	10
26' – 31'	1 – 1½	3	5	5 – 7½	15
36' – 41'	1½ – 2	3 – 5	5 – 7½	7½ – 10	20
46' – 51'	2 – 3	5	7½ – 10	10 – 15	—
56' – 61'	—	7½	10	15 – 20	—

\*Requirements above are for dry grain. High moisture grain will require additional horsepower.

**DISCLAIMER:** These augers were proudly designed to handle dry, free-flowing grains up to a maximum density of 65 lb/bu (52 lb/cf). Any usage of this auger outside of this is not authorized by AGI



Part Number	Description	Weight (lbs)	List Price	Back Freight
<b>4" UTILITY AUGER</b>				
02-UB0411	4" x 11' Upper Basic Section	66	\$718	\$72
02-UX0405	4" x 5' Extension Tube and Flighting	24	\$289	\$29
02-UX0410	4" x 10' Extension Tube and Flighting	46	\$445	\$45
05-A145	Adjustable Feed Control, optional	4	\$91	\$9
05-A146	Swivel Mount Bracket, optional	2	\$86	\$9
05-A152	4" Metal Intake Hopper	10	\$202	\$20
05-A256	4" Bolt-on Hopper Lid Kit	4	\$54	\$5
05-A210	Small Poly Hopper, Fits 4" Augers	8	\$166	\$17

<b>6" - 8" - 10" HEAVY-</b>				
02-UB06025	6" x 3' Upper Basic Section	75	\$1,003	\$100
02-UB0616	6" x 16' Upper Basic Section	164	\$1,465	\$147
02-UX0605	6" x 5' Extension Tube and Flighting	43	\$423	\$42
02-UX0610	6" x 10' Extension Tube and Flighting	74	\$661	\$66
02-UX0615	6" x 15' Extension Tube and Flighting	109	\$891	\$89
02-UB08025	8" x 3' Upper Basic Section	94	\$1,109	\$111
02-UB0816	8" x 16' Upper Basic Section	228	\$1,811	\$181
02-UB0816T	8" x 16' Upper Basic Section with Triple Grooved Pulley	228	\$1,924	\$192
02-UX0805	8" x 5' Extension Tube and Flighting	67	\$554	\$55
02-UX0810	8" x 10' Extension Tube and Flighting	116	\$882	\$88
02-UX0815	8" x 15' Extension Tube and Flighting	172	\$1,185	\$118
02-UB10025	10" x 3' Upper Basic Section	135	\$1,538	\$154
02-UB1016	10" x 16' Upper Basic Section	304	\$2,571	\$257
02-UB1016T	10" x 16' Upper Basic Section with Triple Grooved Pulley	343	\$2,675	\$267
02-UX1005	10" x 5' Extension Tube and Flighting	106	\$764	\$76
02-UX1010	10" x 10' Extension Tube and Flighting	194	\$1,231	\$123
02-UX1015	10" x 15' Extension Tube and Flighting	281	\$1,686	\$169

<b>13" HEAVY-DUTY</b>				
02-UB1321	13" x 21' Upper Basic Section	649	\$5,696	\$570
02-UX1305	13" x 5' Extension Tube and Flighting	160	\$1,363	\$136
02-UX1310	13" x 10' Extension Tube and Flighting	285	\$2,257	\$226
02-UX1320	13" x 20' Extension Tube and Flighting	539	\$3,861	\$386
05-A188	Optional 13" Hopper Kit, Bots to Shielded Intake	41	\$469	\$47
05-A198	13" Tube Clamp	17	\$255	\$26

<b>6" - 8" - 10"</b>				
02-USP0605	6" x 5' Extension Tube and Flighting	47	\$543	\$54
02-USP0615	6" x 15' Extension Tube and Flighting	113	\$1,004	\$100
02-USP0805	8" x 5' Extension Tube and Flighting	66	\$700	\$70
02-USP0815	8" x 15' Extension Tube and Flighting	168	\$1,363	\$136
02-USP0825	8" x 25' Extension Tube and Flighting	275	\$2,086	\$209
02-USP1025	10" x 25' Extension Tube and Flighting	439	\$2,951	\$295

<b>UTILITY AUGER</b>				
05-A124	6" Intake Flight Support Kit	2	\$127	\$13
05-A126	8" Intake Flight Support Kit	4	\$147	\$15
05-A127	10" Intake Flight Support Kit	5	\$158	\$16
05-A128	6" Intake Hopper	17	\$244	\$24
05-A130	8" Intake Hopper	21	\$297	\$30
05-A131	10" Intake Hopper	33	\$339	\$34
05-A132	6" Truss Kit	49	\$414	\$41
05-A134	8" Truss Kit	56	\$439	\$44



Part Number	Description	Weight (lbs)	List Price	Back Freight
05-A135	10" Truss Kit	66	\$503	\$50
05-A136	30' Cable Kit, 4 Lengths, 5/16" Diameter	20	\$328	\$33
05-A137	40' Cable Kit, 4 Lengths, 5/16" Diameter	27	\$427	\$43
05-A138	6" Tube Clamp	5	\$130	\$13
05-A140	8" Tube Clamp	8	\$143	\$14
05-A141	10" Tube Clamp	10	\$151	\$15
05-A153	6" Feed Control Unit	10	\$127	\$13
05-A155	8" Feed Control Unit	11	\$147	\$15
05-A156	10" Feed Control Unit	15	\$160	\$16
05-A198	13" Tube Clamp	17	\$255	\$26
05-A257	6" Bolt-on Hopper Lid Kit	6	\$62	\$6
05-A258	8" Bolt-on Hopper Lid Kit	8	\$71	\$7
05-A259	10" Bolt-on Hopper Lid Kit	11	\$72	\$7

# TRANSFER AUGERS



# AGI Westfield Transfer Augers

AGI Westfield Transfer Augers have a simple design, are balanced for easy moving and have multiple capacities to match your needs.



Transfer augers are available in 8" and 10" diameters with option of gas, electric or hydraulic drive. These low profile transfers are just 10 3/4" high and are light and manoeuvrable. The hopper fits nicely under hopper bottom bins and trailers for fast and easy unloading.

**Electric Drive** available on 8" and 10" and features a heavy-duty motor mount with enclosed belt guard, belts and pulley\*.

**Electric HP requirements** 8" 3HP | 10" 5HP

**Hydraulic Drive** shipped complete with hydraulic control valve. 8" Single Drive hydraulic transfer requires 10GPM at 650PSI 10", Double Drive hydraulic transfer requires 10GPM at 1000PSI.

**Gas Drive** available on 8" and 10". Features heavy-duty engine mount with adjustable belt tension for engaging and disengaging auger while motor is running. Shipped complete with enclosed belt guard, reduction gearbox, belts and pulley\*.

**Motor Requirements** 8" - 5.5HP | 10" - 7.5 HP

All transfers are shipped complete with undercarriage.  
\*Motor and motor pulley not included.



It's not an ordinary auger...  
It's a Westfield

### SPECIFICATIONS & FEATURES

	HOPPER HEIGHT A	HOPPER LENGTH B	TOTAL LENGTH C	HOPPER WIDTH D	TUBE LENGTH E	SPOUT HEIGHT F	HANDLE HEIGHT G	TUBE DIAMETER H	ELEC. HP REQ	GAS HP REQ	HYD. REQ.
8" VERSION	10 3/4"	48"	105"	35 3/4"	60"	25 5/8"	36 5/8"	8"	3HP	5.5HP	10GPM, 650PSI
10" VERSION	10 3/4"	48"	105"	35 3/4"	60"	25"	37 1/2"	10"	5HP	7.5HP	10GPM, 1000PSI

	8" ELEC.	8" HYD.	8" GAS	10" ELEC.	10" HYD.	10" GAS
WEIGHT WITH DRIVE	365lb	237lb	335lb	410lb	285lb	395lb
WEIGHT, NO DRIVE	275lb	*****	300lb	310lb	*****	320lb

**Disclaimer:** These augers were proudly designed to handle dry, free-flowing grains up to a maximum density of 65 lb/bu (52 lb/cf). Any usage of these augers outside of this is not authorized.

	HANDLE FORCE TO BALANCE
8" ELEC.	40lb
8" HYD.	16lb
8" GAS	26lb
10" ELEC.	45lb
10" HYD.	32lb
10" GAS	30lb

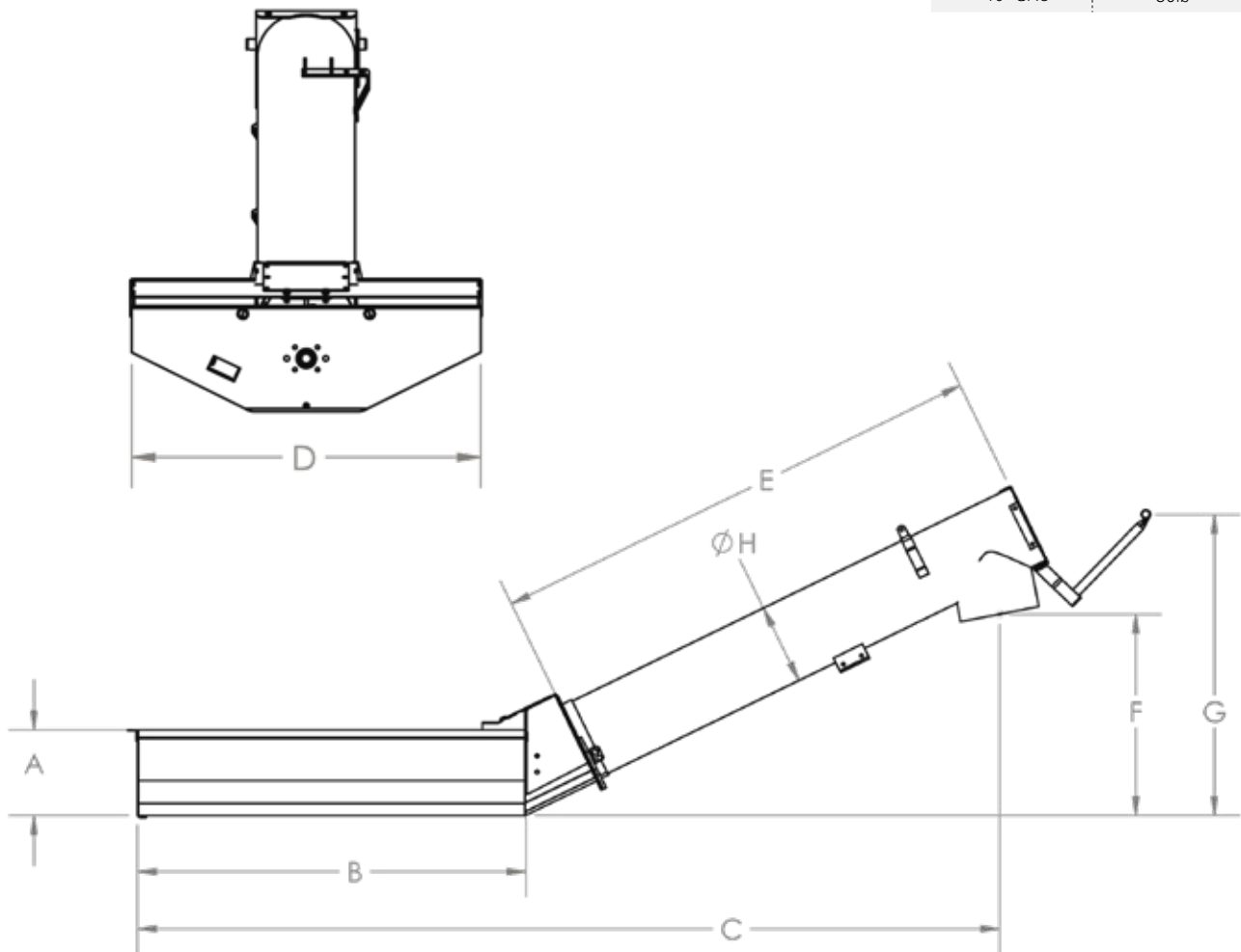

# AGI WESTFIELD

Part Number	Description	Weight (lbs)	List Price	Back Freight
<b>HYDRAULIC</b>				
<i>Comes with variable speed control valve, 3' x 4' x 10-3/4" high hopper, wheel kit, and drive kit. 10" double drive transfer auger features 2 orbit hydraulic motors providing smoother, faster operation. Double drive eliminates the u-joint.</i>				
05-WFTA08H	8" Hydraulic Single Drive Transfer Auger	237	\$4,909	\$491
05-WFTA10H	10" Hydraulic Double Drive Transfer Auger	325	\$6,067	\$607
<b>GAS/ELECTRIC</b>				
<i>Gas Drive - Gearbox (1.5:1)</i>				
05-WFTA08G	8" Gas Drive Transfer Auger	300	\$5,609	\$561
05-WFTA10G	10" Gas Drive Transfer Auger	355	\$6,770	\$677
05-WFTA08E	8" Electric Drive Transfer Auger	275	\$4,207	\$421
05-WFTA10E	10" Electric Drive Transfer Auger	335	\$4,675	\$467
<b>TRANSFER HOPPERS</b>				
<i><b>INCLINED HOPPER (6 FOOT TUBE SECTION):</b> Shipped with pivot wheels, rubber hopper extension, and safety shields. LESS drive, LESS wheel kit. Use with HYDRAULIC or ELECTRIC drive, with optional WHEEL KIT for use independent of auger.</i>				
05-S08-6	8" Inclined Hopper - 6 Foot Section	232	\$2,542	\$254
05-S10-6	10" Inclined Hopper - 6 Foot Section	279	\$2,914	\$291
<i><b>INCLINED HOPPER (9 FOOT TUBE SECTION):</b> Shipped with pivot wheels, rubber hopper extension, and safety shields. LESS drive, LESS wheel kit. Use with HYDRAULIC or ELECTRIC drive, with optional WHEEL KIT for use independent of auger.</i>				
05-S08-9	8" Inclined Hopper - 9 Foot Section	264	\$2,707	\$271
05-S10-9	10" Inclined Hopper - 9 Foot Section	333	\$3,203	\$320
05-S13-10	13" Inclined Hopper - 10 Foot Section	495	\$5,214	\$521
<i><b>LOW-PROFILE TRANSFER HOPPER:</b> Shipped with four wheels, rubber hopper extension, and safety shields. LESS drive, LESS wheel kit. Use with HYDRAULIC or ELECTRIC drive (10" only).</i>				
05-S10-6LP	10" Low Profile Transfer Hopper - 6 Foot Section	475	\$4,601	\$460
05-S10-9LP	10" Low Profile Transfer Hopper - 9 Foot Section	529	\$4,908	\$491
05-S13-10LP	13" Low Profile Transfer Hopper - 10 Foot Section	639	\$6,568	\$657
<i><b>HYDRAULIC DRIVE (FITS 8" AND 10" HOPPERS):</b> Shipped with hydraulic motor, mounting bracket, and drive connector. LESS hose and hose connectors.</i>				
05-H08-2	8" Hydraulic Drive	42	\$2,789	\$279
05-H10-2	10" Hydraulic Drive	47	\$2,829	\$283
<i><b>ELECTRIC DRIVE (FITS ALL STYLE HOPPERS):</b> Shipped with adjustable motor mount, large double pulley (8" and 10") or triple pulley (13"), belts, and shields. LESS motor and motor pulley.</i>				
05-H08-3	8" Electric Drive	37	\$518	\$52
05-H10-3	10" Electric Drive	43	\$596	\$60
05-H13-3	13" Electric Drive	70	\$1,081	\$108
<i><b>WHEEL KIT (FITS ALL STYLE HOPPERS):</b> Shipped with 4.00 x 8 wheels/tires and adjustable carriage. Allows use of hoppers independent of auger when equipped with HYDRAULIC OR ELECTRIC drive.</i>				
05-H08-4	8" Wheel Kit	48	\$720	\$72
05-H10-4	10" Wheel Kit	50	\$727	\$73
05-H13-4	13" Wheel Kit	72	\$1,065	\$106
<b>HOPPER TARPS (SHIPPED WITH HARDWARE INCLUDED)</b>				
05-A160	MK80/100 Standard Hopper Tarp	6	\$389	\$39
05-A167	MK130PLUS Standard Hopper Tarp	7	\$469	\$47
05-A184	MKX/X100/MKX/X130 Low Profile Hopper Tarp	9	\$486	\$49
05-A285	Hopper Tarp fits STX <sup>2</sup> 8/10" Intake Hoppers	6	\$340	\$34
05-A286	Hopper Tarp fits W 13" Intake Hoppers	7	\$378	\$38
<b>DRILL FILL</b>				
03-DF614	6" x 15 1/2' Drill Fill	215	\$4,025	\$403



# **AGI** **WESTFIELD**

<b>Part Number</b>	<b>Description</b>	<b>Weight (lbs)</b>	<b>List Price</b>	<b>Back Freight</b>
03-DF614B	6" x 15 1/2' Drill Fill with Bristle Flighting	220	\$4,863	\$486
05-A142	2 Section Spout	14	\$439	\$44
05-A143	3 Section Spout	17	\$601	\$60

# AUGER TOOLS



# Auger Tools

AGI offers a range of tools for your operation to assist with the maintenance of your auger. Contact us today to place an order!

## Reducer/Reverser Lifter Kits

B001 - 16"

B002 - 13"

This tool will help you quickly lift our 13" or 16" reducer/reverser gearboxes. Hooks onto the cooling fins on the gearbox and provides a simple loop at the top for hoisting.

(1 pcs)

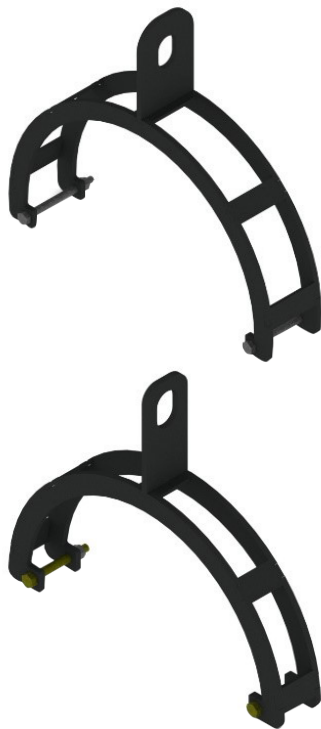

## Gooseneck Hitch Kit

B003

Make towing large augers easier. Simply replace the short tow bar on any 13" or 16" auger and you can tow the auger with better weight distribution on your truck. (1 pcs)



## 5<sup>th</sup> Wheel Hitch Kit

B004

Tow your auger with your 5th wheel truck with ease. Simply replace the short tow bar on any 13" or 16" auger and you can tow the auger with your 5th wheel truck. Allows for better weight distribution on your truck. (1 pcs)



## Boot Lifter Kit

B005

This boot lifter works on your 13" or 16" boots. The adjustable winch bracket makes it easy to balance the boot for easy placement. (1 pcs)



## Reducer/Reverser Puller Kit

B006

This puller fits perfectly over your 13" or 16" gearbox making it easy to remove from the auger. This kit comes with an extra puller rod.



## Sawhorse Kit

B007

A trick to easy assembling. The scratch-free kit is a perfect combination with the tube cradle kits. The tube cradle kits sit nicely on these sawhorses providing a sturdy foundation.

(1 pcs)



## Tube Cradle Kit

B008

Available in all auger tube sizes, the tube cradle kit perfectly cradles your auger. Its rubber padded interior keeps your auger tube scratch free. Includes 4 of each 6", 8", 10", 13", and 16" size cradles.



## Thrust Adjust Wrench Kit

B009

This wrench has been perfectly fitted to easily tighten your thrust adjuster.

(1 pcs)



## Truck Plug Extension Harness

B010

This tool adapts the agricultural 7-pin connector to your automotive 7-pin connector for your auger lights.



## Merchandise Rack

B011

This rack is highly versatile and displays parts ranging from small to large. Well-fitted with parts kit # A485. Built durable and powder coat finished to prevent rust. Comes with parts rack and red bins.

\*Parts sold separately

\*Available in yellow, silver, or red



## Tube Repair Kit

B012

This tool makes it easy to fix any dents on an auger tube. This kit is equipped to fix tube sizes of 6", 7", 8", 10", and 13". With the extension arms, you can reach the dent wherever it is on the tube.

\*Only available in yellow



## Hydraulic Pressure Gauge

B013

Use this gauge to test the pressure your tractor is putting through the hydraulic system.



## Dust Cap Driver Tool

B014

This tool is perfectly made to install the dust cap on all open discharge spouts. Applicable for all MKX<sup>2</sup>/X<sup>2</sup>/HX<sup>2</sup> augers.



## Thrust Adjust Socket

B015

This socket is the perfect size to tighten the thrust adjust nut. Applicable for all MKX<sup>2</sup>/X<sup>2</sup>/HX<sup>2</sup> augers.





Part Number	Description	Weight (lbs)	List Price	Back Freight
<b>AUGER TOOLS</b>				
05-B001	16" Reducer/Reverser Lifter Kit	20	\$114	\$11
05-B002	13" Reducer/Reverser Lifter Kit	15	\$90	\$9
05-B003	Gooseneck Hitch Kit	252	\$785	\$79
05-B004	5th Wheel Hitch Kit	317	\$860	\$86
05-B005	Boot Lifter Kit	10	\$298	\$30
05-B006	Reducer/Reverser Puller Kit	43	\$496	\$50
05-B007	Sawhorse Kit	75	\$334	\$33
05-B008	Tube Cradle Kit	70	\$783	\$78
05-B009	Thrust Adjust Wrench Kit	10	\$69	\$7
05-B010	Truck Plug Extension Harness	2	\$210	\$21
05-B011YL	Merchandise Rack, Yellow	340	\$1,385	\$138
05-B011RD	Merchandise Rack, Red	340	\$1,385	\$138
05-B011SR	Merchandise Rack, Silver	340	\$1,385	\$138
05-B012	Tube Repair Kit	171	\$1,164	\$116
05-B013	Hydraulic Pressure Gauge	3	\$336	\$34
05-B014	Dust Cap Driver Tool	6	\$100	\$10
05-B015	Thrust Adjust Socket	3	\$74	\$7
05-B016	MKX2 13" Clevis	12	\$215	\$22



Part Number	Description	Weight (lbs)	List Price	Back Freight
<b>OPTIONAL</b>				
05-A102	Battery Holder, Bolt on, Fits Motor Drive Augers	8	\$91	\$9
05-A103	Regular Poly Hopper, Yellow, 48" Wide, Fits 6/7/8"	17	\$254	\$25
05-A104	Big Round Poly Hopper, Yellow 50" Diameter, 20" Deep	31	\$480	\$48
05-A109	4.2" x 1" Bore, Single Groove Engine Pulley, Cast Iron	3	\$74	\$7
05-A110	4.2" x 1" Bore, Double Groove Engine Pulley, Cast Iron	4	\$112	\$11
05-A114	Swivel Arc Kit	72	\$723	\$72
05-A119	Replacement Straps for Regular Poly Hopper	1	\$21	\$2
05-A120	Replacement Straps for Big Round Poly Hopper	1	\$26	\$3
05-A121	4.2" x 1-1/8" Bore, Single Groove Engine Pulley, Cast Iron	3	\$76	\$8
05-A122	4.2" x 1-1/8" Bore, Double Groove Engine Pulley, Cast	4	\$106	\$11
05-A147	8" Corn Screen	20	\$715	\$72
05-A148	10" Corn Screen	27	\$791	\$79
05-A150	4.2" x 1-7/16" Bore, Double Groove Engine Pulley, Cast	4	\$114	\$11
05-A160	MK80/100 Standard Hopper Tarp	6	\$389	\$39
05-A163	Poly Bucket Flex Spout, 36" - 5 section, Fits 6/7" Augers	10	\$254	\$25
05-A164	Poly Bucket Flex Spout, 36" - 5 section, Fits 8/10" Augers	14	\$274	\$27
05-A167	MK130PLUS Standard Hopper Tarp	7	\$469	\$47
05-A175	Poly Bucket Spout, 49" - 5 section, Fits 13" Augers	21	\$490	\$49
05-A176	WR6" x 3' Extension	25	\$371	\$37
05-A178	W/WR/WRX8" x 3' Extension	52	\$427	\$43
05-A179	W/WR10" x 3' Extension	76	\$526	\$53
05-A184	MKX/X100/MKX/X130 Low Profile Hopper Tarp	9	\$486	\$49
05-A185	13" Corn Screen	33	\$1,158	\$116
05-A192	Reflector Kit , 26-51"		\$87	\$9
05-A193	Reflector Kit, 61-81"		\$87	\$9
05-A194	Reflector Kit, 91-114	1	\$87	\$9
05-A197	Hydraulic Winch	60	\$2,639	\$264
05-A210	Small Poly Hopper, Fits 4" Augers	8	\$166	\$17
05-A223	Large Poly V-Hopper with Improved Cleanout, Fits	31	\$466	\$47
05-A268	4.2" x 1-1/8" Bore, Triple Groove Engine Pulley, Cast Iron	6	\$137	\$14
05-A277	13" x 3' Extension	110	\$783	\$78
05-A280	16" Poly Bucket Spout	34	\$703	\$70
05-A282	No Snag Flex Spout, 3 section, Fits 10" Augers	8	\$357	\$36
05-A283	No Snag Flex Spout, 3 section, Fits 13" Augers	19	\$573	\$57
05-A284	No Snag Flex Spout, 3 section, Fits 16" Augers	26	\$737	\$74
05-A285	Hopper Tarp fits STX <sup>2</sup> 8/10" Intake Hoppers	6	\$340	\$34
05-A286	Hopper Tarp fits W 13" Intake Hoppers	7	\$378	\$38
05-A442YL	WRX 10" x 3' Extension, Square Shaft	83	\$524	\$52
05-A443	Speed Reducer Kit	156	\$1,555	\$155
05-A456	WRX Steel Caster Wheel Kit	53	\$1,374	\$137
05-A497	SP Motor Bracket Replacement Kit	4	\$102	\$10