

# New Products in 2010

---



---

## 3" High Performance Poly Transfer Pump

Page 61

Achieve the highest performance available in a 3" poly transfer pump (up to 440 gpm) with the highest efficiency and horsepower on the market. Ideal for nurse tank transfer and other closed system applications, this 3" pump was specifically designed to work with 9 and 13 HP PowerPro™ engines and will fit on standard SAE j609a flanged engines between 8 and 18 HP. The polypropylene housing and EPDM elastomers protect the pump from most chemicals and corrosive environments.



---

## GuardianAIR Twin™ Spray Tips

Page 131

GuardianAIR spray tips are scientifically-designed finer air-inclusion tips proven to deliver improved performance in the field. GuardianAIR spray tips combine uniform target coverage and good droplet retention with excellent drift reduction.



---

## Hi-Flow™ Spray Tips with Higher Capacities

Page 142

Hi-Flow tips are engineered for wide angle, large droplet, high volume sprays to deliver fertilizer sprays on-target and with superior uniformity. Hi-Flow tips provide superior performance and ease of use, and are now available in a new, expanded range of sizes that can deliver from 0.8 to 8.5 gpm.



---

## PROstop™ Nozzle Body Valve

Page 182

The PROstop valve provides flow control on the nozzle body for fast spray activation and positive shutoff using a self-propelled sprayer's existing on-board air. Connect several together on one air circuit for boom section control or use in small groups to reduce overlap on headlands.



---

## ProFlo™ Nozzle Bodies for Dry Booms

Page 183

These industry-leading nozzle bodies have flow rates with capacities up to 2.6 gpm at 5 PSI pressure drop. They are now available in a dry boom configuration that is compatible with common boom clamps and include hose barb adapters. Bring high performance to your dry-boom sprayer with ProFlo nozzle bodies.



---

## ProClean Tank and Bottle Rinse Nozzles

Page 190

Increase efficiency and work rates with nozzles demonstrated to clean better, faster, and with less water than conventional tank rinsing nozzles. Get better tank cleaning between loads, more efficient use of clean rinse water, and more effective container rinsing for applicator safety and proper recycling.



---

## Larger Capacity Cleanload™ Chemical Eductor

Page 191

Larger 7 gallon hopper Cleanload models feature a wider 16-inch lid, hold a full 51 lb. bag of dry material, and will rinse large 20-liter (5.2 gal) jugs.

# Table of Contents

---

<b>Pumps and Engines</b> .....	2-120
Technical Information – Hypro Pumps .....	3-14
Centrifugal Pumps.....	15-52
Life Guard® Silicon Carbide Pump Seals .....	53
Self-Priming Adaptor (SPA).....	54
Centrifugal Pump Accessories.....	55
Transfer Pumps .....	57-63
Roller Pumps.....	64-72
Roller Pump Accessories.....	73-74
Other Pump Accessories .....	75
Diaphragm Pumps.....	76-88
Diaphragm Pump Accessories, Kits and Control Units .....	89-92
SHURflo® Pumps .....	93
SHURflo® Diaphragm Pumps.....	94-102
SHURflo® Diaphragm Pump Accessories and Fittings .....	103-104
SHURflo® Mini-Bulk Chemical Transfer Systems and Accessories.....	105-108
Piston Pumps.....	109-113
Hydraulically-Driven Pressure Washers.....	114
Specialty Pumps (Versa-Twin™, Noryl, Turbine and Aqua-Tiger) .....	115-118
Pump Cutaways.....	119
PowerPro™ Gasoline Engines.....	120
<b>Spray Tips, Guns and Backpack Sprayer</b> .....	121-180
Selecting the Right Spray Tip .....	122-126
Broadcast Spray Tips.....	127-144
Streaming Spray Tips .....	145-148
Banding and Directed Spray Tips.....	149-159
Specialty Spray Tips .....	160-167
Technical Information – Spray Tips .....	168-175
Adjustable Pattern Spray Guns.....	176-178
SHURflo® SRS-600 Propack™ .....	179-180
<b>Accessories</b> .....	181-215
Nozzle Bodies and Air-Actuated PROstop™ .....	182-185
Nozzle Body Accessories and Boom Clamps .....	186-187
ProCap™ Tank Lids.....	188-189
ProClean™ and Tank Accessories .....	190
Cleanload™ Chemical Eductor .....	191
Polypropylene Line Strainers.....	192
Nylon Line Strainers .....	193
Flowmeters .....	194
Sprayer Control Valves .....	195
Ball Valves .....	196-197
Gauges .....	198-199
Hose Barb with Fly Nut Fittings and Cam Locks .....	200-201
Fittings, Cable Ties and Clamps.....	202-214
Universal Flanged Gaskets and Sealant .....	215
<b>Value Beyond The Pump</b> .....	216-217
<b>Limited Warranty on Hypro/SHURflo Pumps and Other Hypro Products</b> .....	218
<b>Terms and Conditions of Sale</b> .....	219-220

# Pumps & Engines

---

Because the pump is literally the “heart of the liquid system” on equipment, careful consideration must be made in selecting the right pump. Seldom is there only one pump that will do the job. To make a wise choice, you will need to know about pump types, how the pump is to be driven, and the flow and pressure requirements for your specific spraying system and application.

To ensure you can closely match the pump to your needs, Hypro manufactures six different types of pumps: centrifugal, transfer, roller, diaphragm, piston and plunger pumps.



# Selecting the Right Pump

## “Positive displacement” vs. “Non-positive displacement”

Hypro's long line of pumps can be divided into two general categories: “positive displacement” and “non-positive displacement.” Roller, diaphragm and piston pumps are positive displacement. That is, the flow from the pump is directly proportional to the pump speed. This positive flow is why all positive displacement pump hook-ups must include a relief valve and bypass line between the pump outlet and the nozzle shut-off valve.



Centrifugal and turbine pumps are non-positive displacement. In these pumps, a rotating impeller creates a centrifugal force that feeds the liquid through the system instead of capturing and discharging a fixed volume “per stroke” as rollers, pistons or diaphragms would do. Therefore, if the outlet is closed, the impeller simply continues to rotate harmlessly. That is why special relief valves are not required in centrifugal pump systems.



## Centrifugal and Transfer Pumps (non-positive displacement)

In centrifugal pumps, spray solution enters through the center of a rotating impeller that's driven at speeds up to 6000 RPM. Spray solution is forced to the outer edge of the housing; this centrifugal force is what delivers the liquid to the nozzle. Traditionally thought of as low to medium pressure pumps, Hypro's centrifugal pumps can deliver from 0-190 psi and flow rates up to 440 gpm. Because centrifugals have minimum surfaces to wear and no valves, they are very durable, easy to maintain and well suited for pumping abrasive and corrosive materials.

Because centrifugal pumps operate at higher speeds, the PTO speed must be increased through a speedup gear drive, belt/pulley drive, gas engine drive, or a high-speed hydraulic motor. (Hypro has models specifically designed for each of these applications.)

The broad, versatile line includes models with rugged housings of cast iron, polypropylene and stainless steel that stand up to the wide variety of agricultural chemicals.

# Selecting the Right Pump



## Roller Pumps (positive displacement)

Hypro roller pumps are the number one all-around choice by farmers throughout the world. The rollers (from 4 to 8, depending on the model) revolve inside the pump housing to force the spray solution through the outlet to the nozzle. Roller pumps have a low initial cost and are extremely versatile. They operate efficiently at PTO speeds of 540 and 1000 rpm and have a wide pressure range of up to 300 psi and flow rates of 2 to 62 gpm. Roller pumps are self-priming and easily adapt to PTO or gas engine drives. Specific seal, roller and casting materials can be selected for compatibility with certain herbicides, pesticides, fungicides and fertilizers.



## Diaphragm Pumps (positive displacement)

Because of their design, diaphragm pumps provide excellent handling of abrasive and corrosive materials. The pumping cylinders (from 2 to 6) are separated from the piston chambers (Hypro's are oil-filled) by a synthetic diaphragm. This keeps the spray solution from contacting and corroding the internal pump components.

Diaphragm pumps are compact, self-priming and produce medium-to-high pressures (275 to 725 psi) with flow rates of 3.5 to 65.7 gpm. Driven by 540 rpm PTO, gas engine, DC or hydraulic motor, diaphragm pumps are used for a variety of agricultural, horticultural and pest control spraying applications.



## Piston Pumps (positive displacement)

Piston pumps are not unlike an engine. That is, they have a shaft, pistons and "intake" and "exhaust" valves. On the down-stroke, the inlet valve opens, filling the chamber with solution. On the up-stroke, the outlet valve opens, and the piston forces the solution to the nozzle. Piston pumps deliver relatively low flow rate (up to 10 gpm) at high pressure (up to 1000 psi). The replaceable piston cups can be of leather, fabric or Buna-N rubber, depending on the type of solution to be sprayed. They can be driven by 540 rpm PTO, gas engine or electric motor. Their low volume/high pressure capability permits use in general spraying as well as task-oriented applications such as spraying fence rows and ditches, and hydrostatic testing.

## Hypro Pumps Identification Coding

Hypro uses serialized labeling to enable users to precisely identify the pump when ordering parts or requesting warranty service. Following is an example.

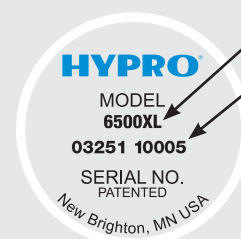

**First line:** Model Number

**Second line:** Serial Number

**First & second digit:** year (03=2003)

**Third through fifth digits:** consecutive day of the year the pump was manufactured.

**Sixth digit:** shift the pump was built on.

**Seventh through tenth digits:** consecutive pump number built on the shift.

# Selecting the Right Pump

## Pump Drives

How a pump is to be driven is often a primary consideration in selecting the proper type of pump. If the power source has already been determined, the following chart may be of further help in selecting the type of Hypro pump that is best suited to your needs.

You can use these pump types:

If your power source is:		Roller	Centrifugal and Transfer	Turbine	Diaphragm	Piston
<b>540 rpm PTO</b>	direct coupled:	✓			✓	✓
	through gear drive:		✓			
	through belt/pulley:		✓			
<b>1000 rpm PTO</b>	direct coupled:	✓				
	through gear drive:		✓	✓		
	through belt/pulley:		✓			
<b>Hydraulic Motor</b>		✓	✓		✓	
<b>12 Volt DC Motor</b>		✓	✓		✓	✓
<b>Gas Engine</b>	direct coupled:	✓	✓			
	through gear reduction:	✓			✓	✓
	through belt/pulley:	✓	✓	✓	✓	✓
<b>Electric Motor</b>	direct coupled:	✓	✓			
	through belt/pulley:	✓	✓	✓	✓	✓

## Pump shaft rotation

With many pumps, you need to specify which direction the shaft rotates... either clockwise (CW) or counterclockwise (CCW). Hypro's rules on shaft rotation are as follows:

### Rule #1 "Eyes on the end"

Always view the rotation when you are facing the end of the drive shaft. If it turns clockwise, it is a clockwise shaft. Always use this rule for determining rotation of the pump shaft and for the power source shaft (PTO, for example). Once you have determined the rotation of the power source shaft, remember Hypro rule #2:

### Rule #2 "Opposites attract"

A clockwise (CW) rotating PTO shaft will require a counterclockwise (CCW) rotating pump shaft, and vice versa. All shaft rotation references in this catalog are based on these two rules.

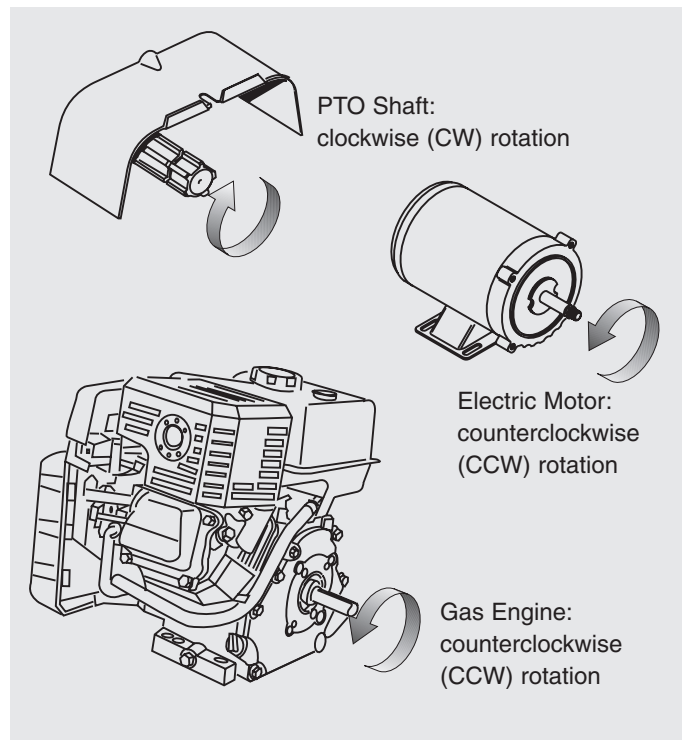

# Determining Pump Flow and Pressure Requirements

Every pumping task has an optimum volume and pressure requirement. Determining that optimum (and selecting the pump that delivers it) is key to an efficient and economical spraying system operation.

Pressure requirements for agricultural pumps are dependent on both the material to be applied and application targets. Soil-applied herbicides generally require a relatively low pressure pump rating of 30-60 psi with foliar-applied herbicides at the top end of that range and slightly higher. Insecticides and fungicides require higher pressure ratings of 100 to 500 psi. Pressure must be sufficient, in the case of heavy foliage field crops and orchard crops, to penetrate the leaf cover. In the case of orchard crops, pressure must also be sufficient to carry material up and over as well as into the canopy.

A number of factors must be considered to properly determine the total flow you will need from your pump. They include:

- Type of spray operation (broadcast, banding, low-level, etc.)
- The chemical's application rate, ground speed, boom width, hose length, tank agitation, etc.

The spray task is the first consideration in determining flow rate and pressure needs. The following formulas and calculations may help.

## Calculating agitation requirements

The pump must produce enough flow for both the application rate and tank agitation requirements. Too little agitation will not keep the solution in proper suspension and too much agitation may cause foaming. Here are rule of thumb formulas for calculating how much additional pump flow you will need for agitation.

### Liquids:

Tank volume (gallons) x .05 = total agitation in gpm

### Wettable Powders and Flowables:

Tank volume (gallons) x .125 = total agitation in gpm

**EXAMPLE:** *If you will be spraying a wettable powder from a 100-gallon tank, proper agitation will require 12.5 gpm additional flow from the pump.*

## Reducing agitation flow requirements

Agitation flow requirements can be reduced by using jet agitation in the tank. Jet agitators use a venturi design to multiply agitation output. Depending on the jet agitator model and pressure, one gallon per minute input can provide two to ten gallons per minute agitation output. If your sprayer is equipped with a jet agitator, consult the operator's manual or documentation to find the output to input ratio and adjust your flow required for agitation accordingly.

For example: If you calculate a requirement of 63 gpm of agitation and your jet agitator requires 3 to 1 output to input ratio, your pump would only need  $\frac{1}{3}$  of 63 gpm, or 21 gpm.

$$\text{Agitation Flow with Jet Agitation} = \text{required gpm} \times \frac{\text{input}}{\text{output}}$$

## Factor in an "Excess Flow" Requirement

It is wise to have some excess flow capacity so you will not end up with an undersized pump because actual operation conditions may cause changes in spray system performance (such as normal pump wear, operating at less than rated speeds, etc.). Hypro recommends you add an additional 20% to your calculated total pump flow requirement to compensate for these variables. Plumbing systems have a number of restrictions that will result in a pressure drop from the pump to the actual spray point. These must be taken into account and minimized.

# Determining Pump Flow and Pressure Requirements



## Calculating pump flow for broadcast boom sprayers

Chemical application is measured in gallons per acre (gpa), whereas pump flow is stated in gallons per minute (gpm). To calculate the pump flow gpm required by a broadcast boom sprayer, multiply the gpa application rate (from the chemical label, usually 10-20 gpa) by the sprayer ground speed (5-10 mph). Multiply the sum by the boom width on your sprayer (in feet). Then, divide that number by 495. As a formula, it is written like this:

$$\text{Flow required for boom (gpm)} = \frac{\text{gpa} \times \text{mph} \times \text{boom width (ft.)}}{495}$$

The result will be the pump flow required to deliver the proper application rate at the boom's nozzles. Then calculate your total pump flow requirement (broadcast):

Flow required for boom:	_____	gpm
Flow required for agitation:	+ _____	gpm
Sub-total	= _____	gpm
Excess flow requirement:	x <u>1.20</u>	
TOTAL PUMP FLOW NEEDED:	= _____	gpm



## Calculating pump flow for banding sprayers

First, multiply the band width (in inches) by the number of rows to determine the total width (w). Then, multiply the application rate (gpa from the chemical label) by the ground speed (mph). Multiply that result by the total width (w) calculated earlier, then divide the result by 5940. Here's how the formula appears:

$$\text{Flow required for nozzles (gpm)} = \frac{\text{gpa} \times \text{mph} \times w}{5940}$$

For total pump flow requirement (banding), calculate:

Flow required for boom:	_____	gpm
Flow required for agitation:	+ _____	gpm
Sub-total	= _____	gpm
Excess flow requirement:	x <u>1.20</u>	
TOTAL PUMP FLOW NEEDED:	= _____	gpm



## Calculating pump flow for hand gun spraying

For low-level spraying with a hand gun, such as for lawn and turf care, professional applicators typically "walk" the lawn at about 1,000 sq. ft. per minute. That means the "gpm" rate of the hand gun will generally be the same as "gallons per 1,000 sq. ft." To determine your total pump flow requirement:

Flow required for gun/nozzle:	_____	gallons per 1,000 <sup>sq. ft.</sup> (same as gpm)
Flow required for agitation:	+ _____	gpm
Sub-total	= _____	gpm
Excess flow requirement:	x <u>1.20</u>	
TOTAL PUMP FLOW NEEDED:	= _____	gpm

Use this same method for calculating the pump flow requirement for high pressure spraying, such as trees. Even though the application "rate" is usually a visual saturation of the tree, the known gpm factor will be the hand gun nozzle output, which is the rate you use for the calculation.

# Determining Pump Flow and Pressure Requirements

## Calculating pump pressure for hand gun spraying

For most hand gun chemical spraying, 40 psi at the nozzle is typical. To properly select a pump that can deliver the right nozzle pressure, you must consider the normal “pressure drop” that occurs within the length of hose. The amount of pressure drop through the hose depends on hose length, hose diameter and flow rate. For example, as the accompanying chart shows, 300’ of ½” hose spraying at 6 gpm, will have a pressure drop of approximately 120 psi. That means you need a pump delivering at least 160 psi in order to ensure 40 psi at the nozzle.

NOTE: When determining the total pump pressure requirement for high tree spraying, you must also consider the spray height (or reach) you need to attain. Generally, pumps of up to 700 psi are used for this purpose.

Desired pressure at gun nozzle:	_____	psi
Hose pressure loss:	+ _____	psi
<b>TOTAL PUMP PRESSURE NEEDED:</b>	<b>= _____</b>	<b>psi</b>

**Pressure Loss at Various Rates of Flow of Water Through Hose\***  
 at temperature of 68° Fahrenheit (20°C.)  
 \*¼-inch to 1-inch inside diameter

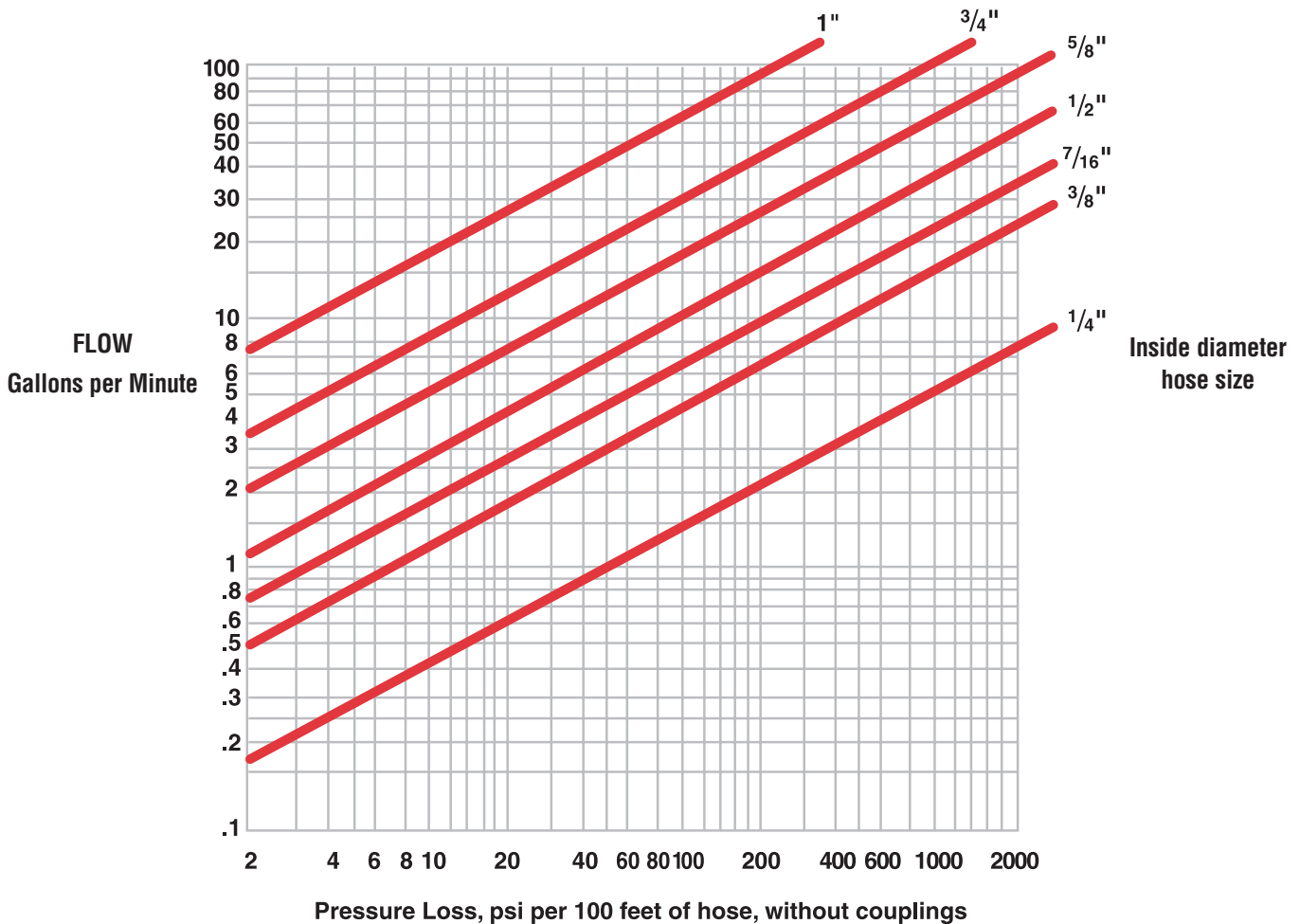

# Hand-held Spray Gun Performance

## at Various Pressures and Nozzle Sizes

When selecting system components for hand gun spraying, factors such as flow rate, vertical “throw”, nozzle size, spray pattern and pressure must be considered. The following chart provides data for capacity (gpm) and maximum vertical throw in feet (ft.) at a variety of pressures and nozzle sizes, as well as for “cone” or “straight” spray patterns.



**Performance Chart for Models 3381-0010, 3381-0011 and 3381-0013 Spray Guns**

Hypro Model #	Orifice Diameter In MM	Equiv. Nozzle #	Pressure In PSI**	200 PSI Setting		350 PSI Setting		500 PSI Setting		600 PSI Setting		650 PSI Setting		700 PSI Setting		850 PSI Setting	
				Cone	Straight	Cone	Straight	Cone	Straight	Cone	Straight	Cone	Straight	Cone	Straight	Cone	Straight
3385-1500	2.3	14	capacity in gpm max throw (ft)*	1.14 9.2	1.26 21.5	1.48 10.3	1.7 25.2	1.8 11.2	2 28	1.9 12.1	2.2 31.8	2 12.1	2.3 32	2.1 12.3	2.4 32.3	2.2 13.1	2.5 34.3
3385-2300	2.3	14	capacity in gpm max throw (ft)*	2.1 11.4	2.7 29	2.7 12.9	3.7 33.9	3.4 14.8	4.5 37.9	3.8 16.6	4.9 41.5	3.8 17	5 41.7	3.9 17.7	5.1 42	4.2 19	5.8 45.7
3385-3000	3	23	capacity in gpm max throw (ft)*	2.9 11.7	4.6 29.2	3.7 12.9	6.3 33.9	4.8 13.8	7.5 36.2	5.2 15.6	8.4 40.8	5.3 16	8.5 40.7	5.4 16.2	8.6 42	6 17	9.6 44.1
3385-3500	3.5	29	capacity in gpm max throw (ft)*	5.8 13.6	6 36.2	7.9 19	8.2 41.2	9.6 22.6	9.9 45.3	10.7 25.5	11.1 50	11 25.5	11.3 51	11.2 27	11.6 51.5	12.4 28.8	12.8 54
3385-4000	4	40	capacity in gpm max throw (ft)*	7 15.1	7.3 37.7	9.6 20.6	9.9 42.8	11.6 24.3	12 47	12.9 27.2	13.5 53	13.2 27.2	13.8 54	13.6 28.5	14.1 55	15 29	15.6 59
3385-4500	4.5	54	capacity in gpm max throw (ft)*	8.2 18.1	8.9 39.2	11.1 22.2	12 44.3	13.4 26	14.5 50.1	15 30.6	16.3 54	15.4 30.6	16.6 56	15.7 31	17 57	17.4 31.5	18.9 62
3385-5000	5	67	capacity in gpm max throw (ft)*	9.8 19.6	10.2 40.7	13.3 23.8	13.8 47	16 27.5	16.7 53.3	18 32.3	18.7 59	18.4 32.3	19.1 61	18.9 32.8	19.5 62	20.8 32.8	21.6 67
3385-5500	5.5	79	capacity in gpm max throw (ft)*	10.7 19.6	11.5 42.2	14.4 23.8	15.6 50.7	17.4 29	18.8 57	19.6 34	21 63	20 34	21.5 64	20.4 34.5	22 65	22.6 34.5	24.4 70
3385-6000	6	91	capacity in gpm max throw (ft)*	11.5 21.1	12.6 43.7	15.6 25.3	17.1 54	18.8 30.7	20.6 60	21 35.6	23.2 66	21.5 35.6	23.7 67	22 36	24.2 68	24.4 36	26 97.4
3385-7000	7	117	capacity in gpm max throw (ft)*	11.5 21.1	13.5 46.8	15.6 25.3	18.4 57	18.8 30.7	22.2 63	21 37.4	25 70	21.5 37.4	25.4 71	22 38	26 72	24.4 38	29 77

\* Figures shown are guidelines for vertical throw.  
 \*\* Pressures based on relief valve settings at straight throw.

# Recommended Pump Placement

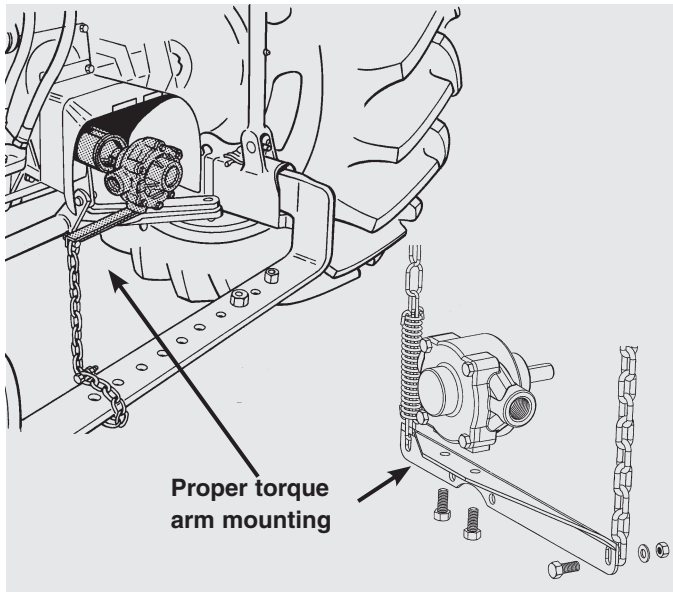

## PTO DIRECT-MOUNT

Location of PTO-driven pumps and pump drive units may have a significant effect on pump life. Mounting the pump directly to the PTO is always a good choice. Even though installation is relatively easy, use caution to ensure the shaft does not get bent or damaged. Always use a quality, properly secured coupler and provide adequate support for the pump itself in order to withstand the extreme bouncing and vibration the system must endure. PTO mounting shields should always be used for maximum safety and protection.

## TUMBLE ROD MOUNTING

If direct PTO mounting is not convenient or desired, then mount the pump in a convenient position on the pull-behind sprayer and connect it to the tractor PTO with a "tumble rod" power shaft. Exercise caution when using this approach to ensure: (1) the tumble rod is level; (2) the hitch pin is the center-point; and (3) turn angles greater than  $45^\circ$  can be avoided. Failure to follow these three points may cause "power shocks" within the pump and drive units and increase wear on seals, gears, and, in the case of diaphragm pumps, the diaphragms themselves.

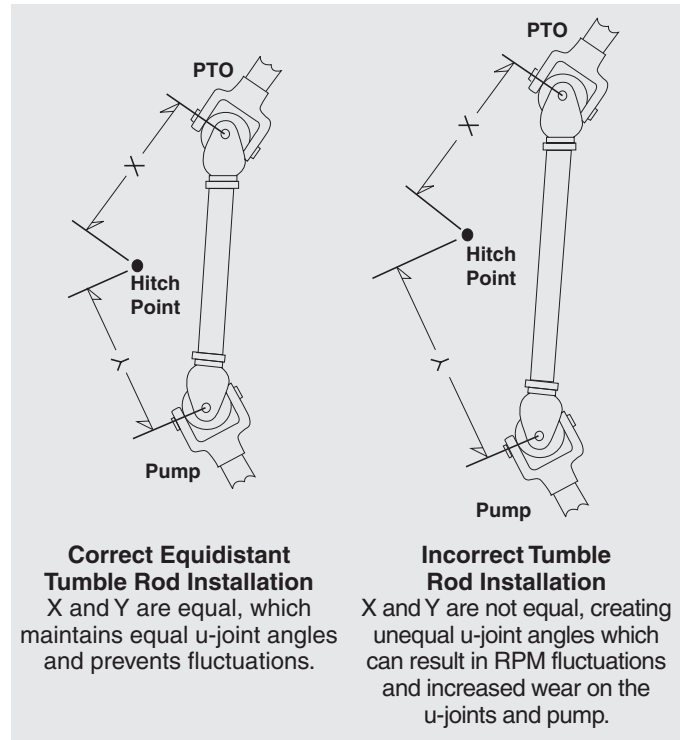

The best tumble rod installation occurs when the distance from the PTO U-joint to the hitch is equal to the distance from the hitch to the pump U-joint. For 540 RPM PTO shafts, the distance from the hitch pin to the pump shaft should be 14 inches. For 1000 RPM  $1\frac{3}{8}$ " PTO shafts, the distance is 16 inches. For 1000 RPM  $1\frac{3}{4}$ " PTO shafts, the distance is 20 inches. Instances where equal distances are not possible, a "constant velocity" shaft should be used.

Power shocks occur when the PTO shaft knuckle and the universal joint at the pump end of the tumble rod turn faster on the inside of the turning angle than on the outside. To prevent these vibrations, the angle of the tumble rod to the tractor PTO shaft and the angle of the tumble rod at the pump shaft should be as close to equal as possible. This will cancel out the fluctuations.



Improperly calibrated sprayers threaten the wallet and the environment. A few minutes spent calibrating a sprayer can ensure expensive inputs go where they are supposed to and at their recommended rate. Proper calibration exposes under-pressured systems and worn tips that can sabotage a spray program and its budget. Follow these steps to calibrate your sprayer safely and effectively.

1. The first step in any calibration effort is to check tractor speed. Mark off lengths of 100 and 200 ft. for measuring tractor speeds of 5 mph and 10 mph, respectively. Fill the sprayer tank half full of water, select the engine throttle setting and gear that you expect to use when spraying, and then record the seconds required to drive the length of each course twice at their respective settings. Average the results of each set, and use the following equation to determine ground speed.

$$\text{Speed} = \frac{\text{Distance (ft.)} \times 60}{\text{Time (sec.)} \times 88}$$

Repeat the test as needed until the correct speed is identified. Mark that setting on the tachometer or speedometer for in-field reference.

2. Record the nozzle spacing, nozzle type, ground speed and product label application rate. Check to ensure all nozzles are of a uniform type.

3. Multiply the application rate (gpa) by the speed (mph) and the width of the spray pattern (w)\*. Divide this amount by 5940 (a constant) to determine the gallons per minute (gpm) produced by each nozzle.

$$\text{Flow required per nozzle (gpm)} = \frac{\text{gpa} \times \text{mph} \times \text{w}}{5940}$$

4. To set correct pressure, operate the water filled sprayer in place to check for leaks and stoppages. Stop the sprayer, and replace one tip on the boom with an identical new tip and strainer. Check the tip product information sheet for recommended delivery rate and pressure that matches the gpm level calculated in Step 3.

Engage the sprayer and adjust for recommended pressure. Collect the volume of spray produced from the new nozzle tip over a one minute period. Measure the water, and fine tune the pressure setting until the calculated delivery rate is reached.

5. Repeat the collection procedure with several tips on each boom section. If variations in flow in excess of 10% are produced from more than one tip, replace all old tips and screens.

\*If calibrating a sprayer for broadcast application, use nozzle spacing for spray pattern width. If calibrating for banding, use only actual spray pattern in inches (12 bands of 10" each on 30" rows equals spray pattern width of 120" on a 30' boom).

Directed applications with multiple nozzles require that the row or band in inches be divided by the number of nozzles directed at the row to calculate width.

$$\text{Width of Spray Pattern in Directed Applications} = \frac{\text{band width}}{\# \text{ of nozzles per band}}$$

# System Hook-Ups

## Roller, Diaphragm and Turbine Pumps

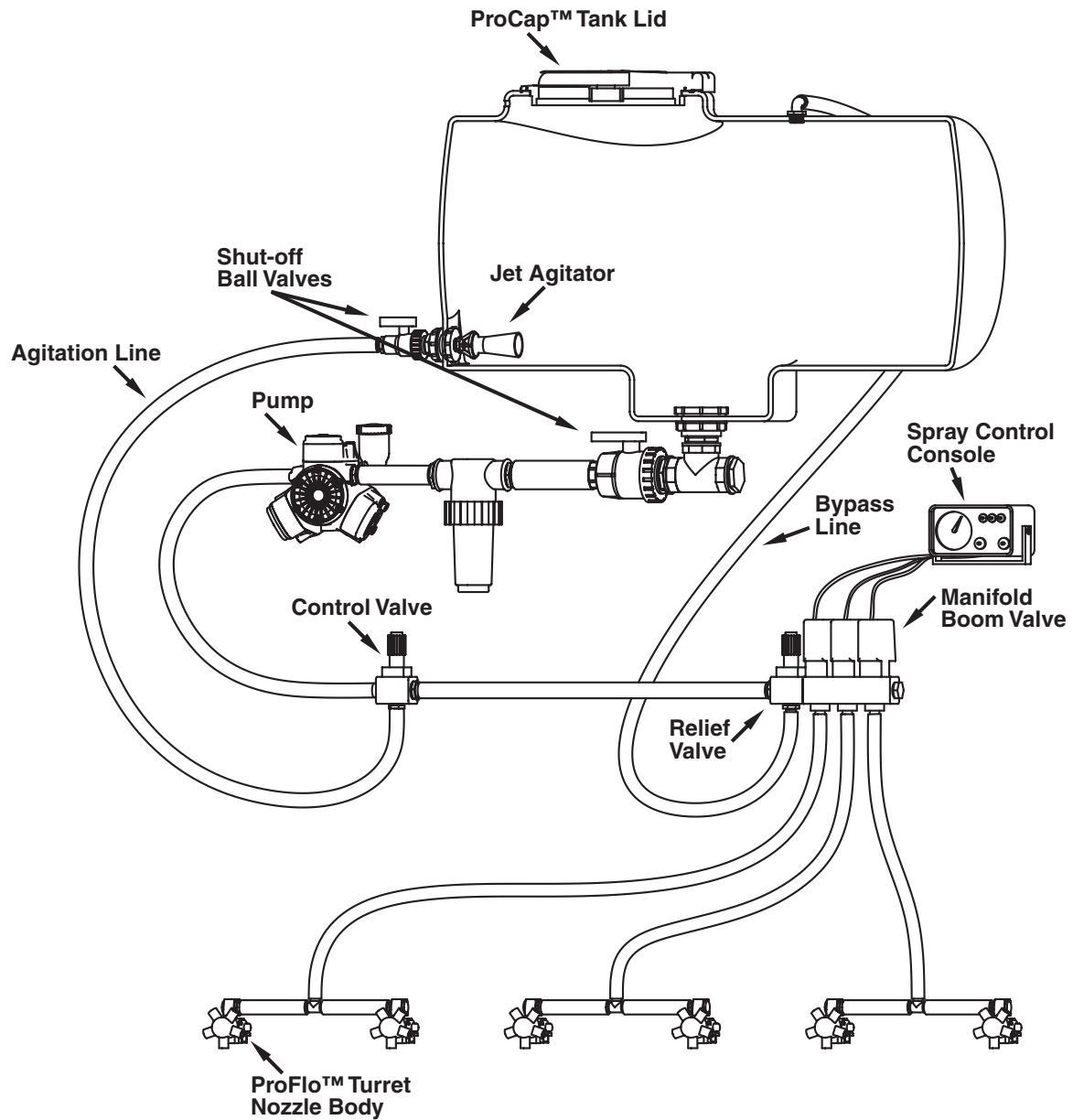

Hypro carries all parts labeled above. Please contact your local Hypro dealer or call 1-800-424-9776 for more information.

# System Hook-Ups

## Centrifugal Pumps

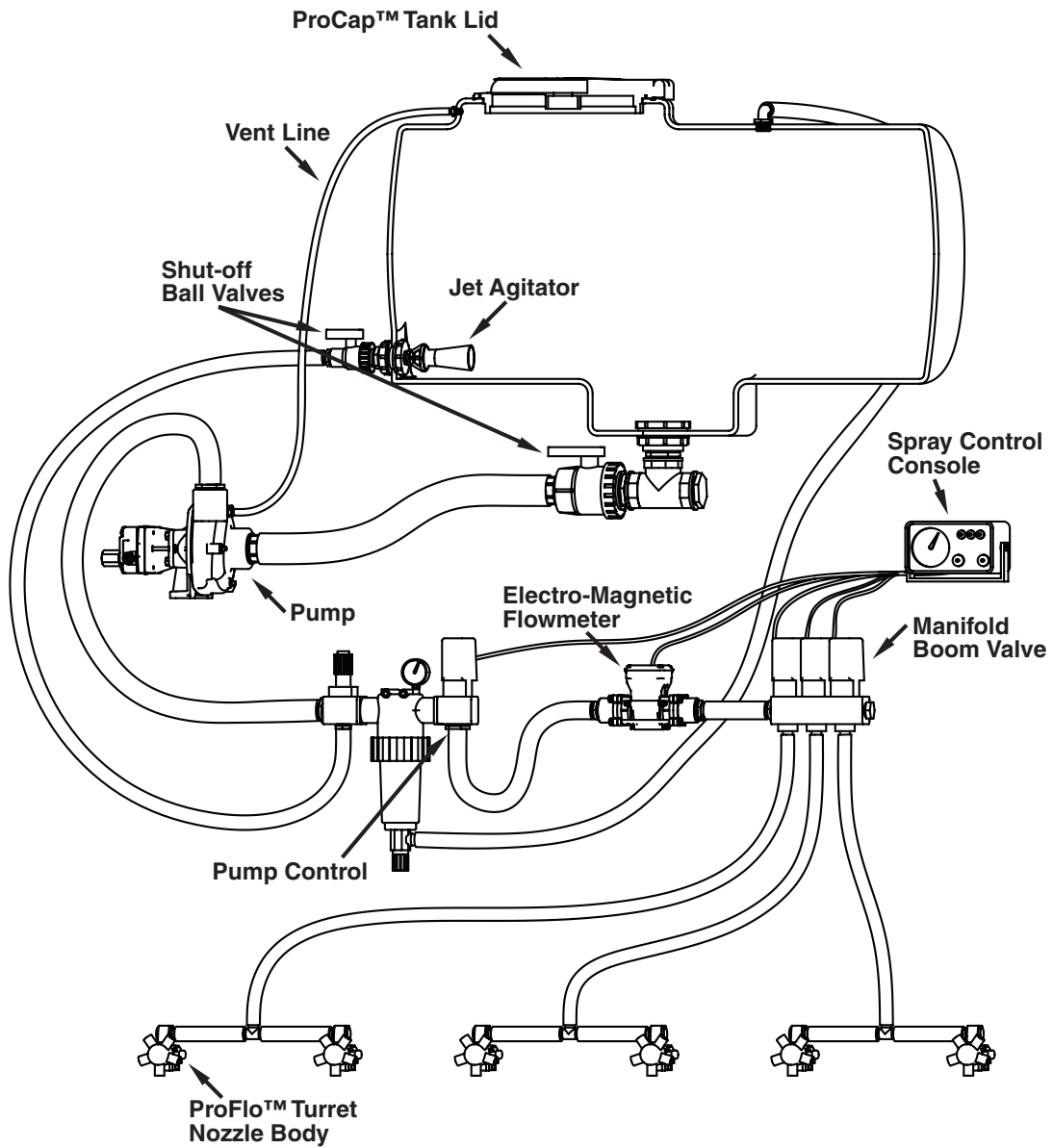

Hypro carries all parts labeled above. Please contact your local Hypro dealer or call 1-800-424-9776 for more information.

# System Hook-Ups

## Small Twin® Piston Pumps

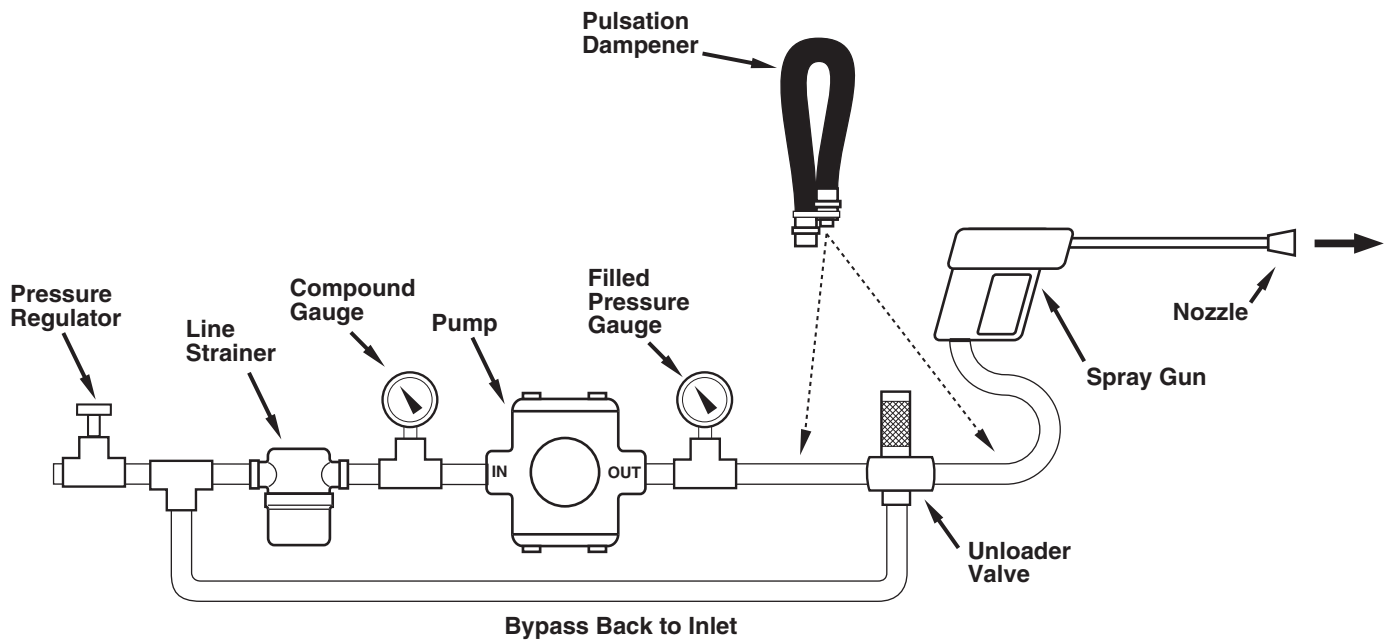

Hypro carries all parts labeled above. Please contact your local Hypro dealer or call 1-800-424-9776 for more information.