

BELCO RESOURCES EQUIPMENT

Quality Products for
YOUR Land, from Brands
YOU Love!



SUGGESTED RETAIL PRICEBOOK JULY 2023

NOTE: DUE TO MANUFACTURER TRADE AGREEMENTS, SOME PRODUCTS MIGHT NOT BE AVAILABLE IN CERTAIN AREAS.
PLEASE CHECK WITH YOUR TERRITORY REPRESENTATIVE FOR MORE DETAILS.

DEALER RESOURCES

SALES

Email:	sales@br-equipment.com (for general inquiries) orders@br-equipment.com (for placing orders via Email)
Phone:	(252) 822-7140 Option 1
Fax:	(252) 787-5855

ACCOUNTING

Email:	accounts@br-equipment.com
Direct Phone:	(252) 822-7140 Option 4
Fax:	(252) 787-5855

PARTS

Email:	parts@br-equipment.com
Direct Phone:	(252) 822-7140 Option 2
Fax:	(252) 787-5855

WARRANTY/SERVICE

Email:	service@br-equipment.com
Direct Phone:	(252) 822-7140 Option 3
Fax:	(252) 787-5855

SHIPPING

Phone:	(252) 316-2121 (252) 557-4822
--------	----------------------------------

MANUALS AND BROCHURES

Website	www.br-equipment.com
---------	--

ONLINE DEALER ACCESS

Login Information	<i>See your Sales Representative</i>
What you can access here:	<ul style="list-style-type: none">◇ Wholegoods Order Forms◇ Parts Order Forms◇ Brochure Request Forms◇ Warranty Registration Forms◇ Warranty Claim Forms

CONTENTS BY MANUFACTURER



TAR RIVER IMPLEMENTS

BALER—MINI ROUND	28
BELT RAKE	26
BOX BLADES	75
CHAIN AND PASTURE HARROWS	46 – 49
CULTIPACKER	73
CROP SEEDER	38 – 39
DISC HARROWS	72
DITCH BANK MOWERS	53
DRILL—NO TILL	40 – 41
DRUM MOWERS	12
FINISHING MOWERS	50
FLAIL MOWERS	51
HAY TEDDER	16 – 17
HILLER/RIPPER	78
LAND LEVELER	76
LANDSCAPE RAKES	70
MINI ROUND BALER	28
MIDDLE BUSTERS	78
PLOWS (1 & 2 BOTTOM)	78
POST HOLE DIGGER	77
QUICK HITCHES	79
REAR BLADES	71
ROTARY CUTTERS (3 PT)	64 – 65
ROTARY RAKE (R-RAKE)	27
ROTARY TILLERS	32 – 37
SUB-COMPACT (DLT SERIES)	32
COMPACT (TXG SERIES)	33
MEDIUM-DUTY (YCT SERIES)	34
MEDIUM-DUTY REVERSE ROTATION	35
HEAVY DUTY (RXT SERIES)	36
MULTI-SPEED GEARBOX (CXT)	37
SHANK CULTIVATOR	74
SPREADERS	66 – 69
3 POINT	66
PULL-TYPE	67
COMPACT SIDE SHOT	68
PENDULAR	69
SUB-SOILERS	78
TRACTOR TOOLS	78 – 79
TRAILER MOVER (3 PT)	79
WOOD CHIPPERS	82



ORSI

DITCH BANK	54 – 55
FLAIL MOWERS	52
HYDRAULIC BOOM MOWERS	56 – 63
HEDGE	56
CUT REVERS	57
RIVER COMPACT	58
RIVER COMPACT PLUS	59
PERFORMANCE	60
PERFORMANCE PARALLELOGRAM	61
PERFORMANCE PARALLELOGRAM VISUAL	62
COMPARISON CHART	63



DELTA HARROWS	CHAIN HARROWS	46 – 47	
	ECONO-WRAP	SINGLE BALE WRAPPERS	29 – 30
		STATIONARY	29
SELF-LOADING		30	
ENOROSI	DISC MOWER	8 – 9	
	MOWER CONDITIONERS	10 – 11	
	SICKLEBAR MOWER	13	
	HAY TEDDERS	14 – 15	
	HAY RAKES	18 – 25	
	CARTED WHEEL RAKE	22	
	BAT RAKE	23	
	MAXIMUS RAKE	24	
	EASY RAKE	25	
	THREE POINT WHEEL RAKE	21	
	TEDDER RAKE	20	
	ROTARY RAKE	18 – 19	
	TAJFUN	SKIDDING WINCHES	80 – 81
		TAR RIVER ATTACHMENTS	ADAPTER BRACKETS
	BALE GRABBERS		90
BALE SPEARS	89		
BALE UNWINDER	90		
BRUSH CUTTERS (SKID LOADER)	96 – 97		
HEAVY DUTY	96		
SERIOUS DUTY	97		
BUCKETS	91		
BEAST SERIES	91		
COMPACT UTILITY	91		
GRAPPLES	92 – 94		
UTILITY ROOT GRAPPLES	92		
COMMERCIAL ROOT GRAPPLES	93		
CLAW GRAPPLES	94		
PALLET FORKS	86 – 88		
SUB-COMPACT	86/87		
COMPACT	86/87		
MEDIUM DUTY	86/87		
HEAVY DUTY	86/87		
HYDRAULIC	88		
WALK-THRU	88		
POST DRIVER	95		
QUICK-ATTACH PLATES	100		
SNOW REMOVAL	98		
TOOTH BARS	100		
GREENSCAPE	CONSERVATION SEEDER		44 – 45
	FOOD PLOTTER (NO-TILL DRILL)		42 – 43
	LIFT-SAFE IMPLEMENT HANDLER		101
KEMCO	INLINE BALE WRAPPER	31	



Tar River

Available in 2 popular sizes, the Tar River side-mounted Disc Mower is built strong to stand up to years of rough conditions, giving you an excellent, quality cut. The reinforced A-frame made of heavy square tubing with Category II & III three-point hitch and the durable compensation spring ensure stability and durability during work.

The V-Belt and Shear-Hub systems protect the cutter-bar in the case of hitting obstacles. The break-away system provides additional protection to the cutter-bar by allowing it to pivot backwards when it encounters an obstruction. Simply back the tractor up and the break-away bar and mower will reset into the working position.

The cutter-bar is designed for quick and easy replacement of each of the individual cutting units, which eliminates the need to take apart the entire cutter-bar for most repairs.

Models available: 5 and 6 disc configurations.



Each unit comes with a tool to change the blades & an extra set of blades!

Standard Equipment:

- ◇ PTO Shaft 460 Nm
- ◇ Comer Cutter bar with SAFETY DEVICE SYSTEM
- ◇ Protective Barriers made of a Bent Pipe Profile
- ◇ Protective Apron—reinforced with a rubber collar
- ◇ Key for quick knife replacement
- ◇ Spring-based relief system
- ◇ Adjustable lower hitch pins
- ◇ Break-Away System

Disc Mowers



MOWER FEATURES

LIFTABLE FRONT COVER + PROTECTIVE APRON
Easy access to the cutter bar to replace knives or a damaged bearing assembly.

HYDRAULIC CYLINDER
Facilitates maneuvering and transport of the machine.

BREAK-AWAY BAR
Protects the mower from damage.

SPRING RELIEF SYSTEM
Relieves the pressure of the cutter bar on the ground, increasing its life span:

- ◇ Increases the range of terrain following ability
- ◇ Infinite ground pressure adjustment
- ◇ 0" - 8" range of terrain following



Easy Blade Change

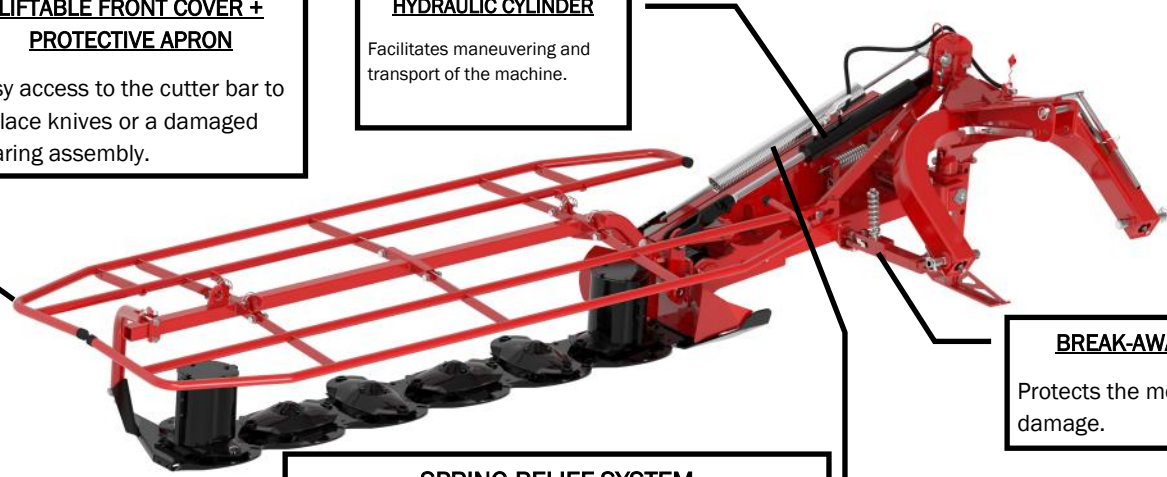

CUTTING BAR WITH SAFETY SHEAR-HUB

Shear Hub Protection for "Comer" Cutter bar

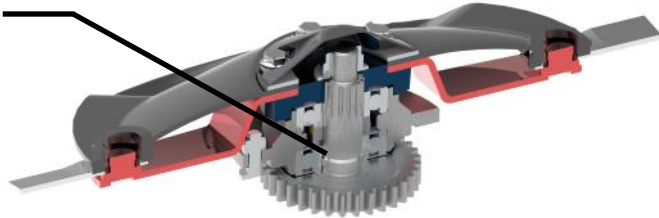

Model	No. of Discs	Blades per Disc	Working Width	HP	Wt. lbs.	List Price
DCM2083	5	2	6'11"	30	1,096	\$9,480
DCM2098	6	2	8'2"	45	1,162	\$10,280

DISC MOWERS



Available in 5 popular sizes, the Enorossi side-mounted Disc Mower is built strong to stand up to years of rough mowing conditions, giving you an excellent quality cut. The heavy duty A-frame with Category 1 & 2 three-point hitch and the strong compensation spring ensure stability and durability.

The V-Belt and Shear-Hub systems protect the cutter-bar in the case of obstacles. The break-away system provides additional protection to the cutter-bar by allowing it to pivot backwards when it encounters an obstruction. Simply back the tractor up and the break-away bar and mower will reset into the working position.

The cutter-bar is designed for quick and easy replacement of each of the individual cutting units, eliminating the need to take apart the entire cutter-bar for most repairs.

Models available: 4, 5, 6, 7, and 8 disc configurations; 3-blade discs available on 4, 6 and 8 disc models.



Disc conveyor bolted on top of guard support to avoid wrapping problems



Anti-wrapping support for heavy grass



Moves 90° for transport - will cut at 35° up or down for hills, banks, terraces, etc.

Specifications:

- ◇ “Sneak-A-Peek” belt tension viewer for less down time
- ◇ Compensation spring “break-away” system
- ◇ Heavy Duty shield PTO shaft with overrunning clutch
- ◇ Hydraulic cylinder lift mechanism
- ◇ High blade tip speed for smooth, fast cutting efficiency



Easy changing hubs with 4-bolt disc cutting unit



Easily adjust belt tension without taking off outer cover



Heavy Duty A-Frame



Individual Shear-hub System on cutter bar

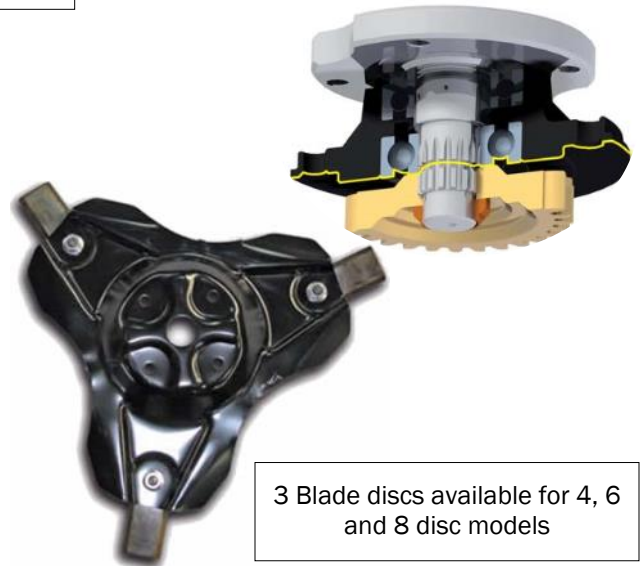

3 Blade discs available for 4, 6 and 8 disc models

Model	No. of Discs	Blades Per Disc	Working Width	Lift	HP	PTO	Wt. lbs.	Wt. Ship lbs.	List Price
DM4	4	2	5'5"	Hydraulic	35	540 RPM	925	982	\$9,590
DM4 3C	4	3	5'5"	Hydraulic	35	540 RPM	931	986	\$9,730
DM5	5	2	6'7"	Hydraulic	40	540 RPM	1,015	1,070	\$10,265
DM6	6	2	8'	Hydraulic	50	540 RPM	1,103	1,158	\$10,940
DM6 3C	6	3	8'	Hydraulic	50	540 RPM	1,109	1,164	\$11,190
DM7	7	2	9'2"	Hydraulic	60	540 RPM	1,413	1,488	\$14,250
DM8	8	2	10'5"	Hydraulic	70	540 RPM	1,523	1,698	\$15,250
DM8 3C	8	3	10'5"	Hydraulic	70	540 RPM	1,532	1,707	\$15,550

TREX MOWER



A side drawbar is the main feature characterizing our pull-type Disc Mowers with Conditioner series DMC-TREX 290 – 320. The drawbar can be hydraulically shifted and the block valve ensures a secure locking system. It is possible to choose between models without conditioner, FLAX models with blades conditioner and ROLL models with roller conditioner. A perfect cutting quality is assured by the Enocut cutting bar system.

Standard tires 340/55-16 12PR and second wide angle PTO Drive shaft.



High Quality Cutting Bar with 2 Year Limited Warranty

Specifications:

- ◇ Easy changing hubs with 4-bolt disc cutting unit
- ◇ Individual Shear Hub system on cutter bar
- ◇ Heavy Duty shield PTO shaft with overrunning clutch
- ◇ Hydraulic cylinder lift mechanism
- ◇ High blade tip speed for smooth, efficient, and fast cutting
- ◇ Adjustable Swath Diverter

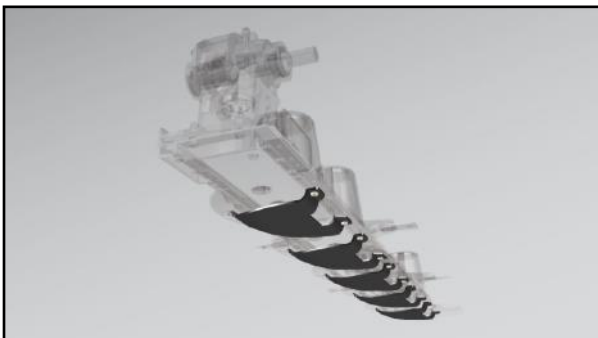

Optional Wearproof Skids Available

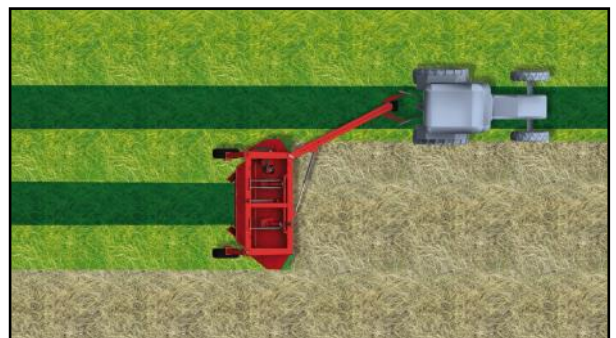

Working Position

CONDITIONER



Steel FLAX Tine Conditioner



Double Rubber Roller Condition



Model	N° discs	Working width	Conditioner Type	HP	Weight
RUBBER ROLLER CONDITIONER					
TREX250-ROLL	6	96"	Roller	45-85	3,634 lbs.
TREX290-ROLL	7	114"	Roller	50-85	3,970 lbs.
TREX320-ROLL	8	126"	Roller	55-85	4,300 lbs.
FLAX TINE CONDITIONER					
TREX250-FLAX	6	96"	Flax Tine	45-85	3,484 lbs.
TREX290-FLAX	7	114"	Flax Tine	50-85	3,815 lbs.
TREX320-FLAX	8	126'	Flax Tine	55-85	4,150 lbs.

Prices and specifications subject to change without notice. Check discounts & availability before quoting.
 Product Designs May Differ Slightly Than What Appears in the Photographs.

DRUM MOWERS



Make Sure to Check Tractor Weight!

Tar River Implements Drum Mowers have very few moving parts, are low maintenance and have a heavy built A-frame, the Tar River Drum Mower is a great economic alternative to the Disc and Sicklebar Mowers while still giving a good cut. The BDR Series Drum Mower can mow at high speeds and offer reliable mowing in all conditions, easily cutting through tall and thick grasses. Available in 4 popular sizes, Tar River Implements has a perfect fit for your small hay operation.

Drum Mower Benefits:

- ◇ Mow at High Speeds
- ◇ No Hydraulics Necessary
- ◇ Few Moving Parts & Easy Maintenance
- ◇ Great Alternative to Disc & Sicklebar Mowers for Small Hay Producers
- ◇ Easily Cuts Through Tall and Thick Grass
- ◇ Designed for Reliable Mowing in All Conditions

BDR Series Drum Mower Features:

- ◇ Heavy Duty A-frame
- ◇ 3 Blades per Drum (2 on the BDR-135 & 4 on BDR-210H)
- ◇ Compensation Spring "Break-Away" System
- ◇ High Blade Tip Speed for Smooth, Fast Cutting Efficiency
- ◇ V-Belt Drive
- ◇ Internal Overrunning Clutch
- ◇ Easy & Quick Blade Change

Model	No. of Drums	Blades Per Drum	Category Hitch	Working Width	Min. Recommended Tractor Weight	Lift	Min HP	PTO	Wt. lbs.	List Price
BDR-135	2	2	Cat. 1	4'5"	2,100 lbs.	Manual	20	540 RPM	661	\$3,840
BDR-165	2	3	Cat. 1 & 2	5'5"	2,600 lbs.	Manual	28	540 RPM	794	\$3,940
BDR-185	2	3	Cat. 1 & 2	6'1"	3,900 lbs.	Manual	35	540 RPM	893	\$4,700
BDR-210H	2	4	Cat. 2 & 3	6'9"	6,500 lbs.	Hyd.	65	540 RPM	1,240	\$6,710
BDR-A80	Hydraulic Lift Kit for BDR-165/185									\$570

SICKLE BAR MOWERS



These double action Sickle Bar Mowers with an adjustable 3 point hitch ensure a sharp clean cut on any type of grass. The safety breakaway bar helps protect the cutter from obstructions in the field.



Safety breakaway bar

Specifications:

- ◇ Three Point Hitch Cat.1 & 2
- ◇ Double Action cutter bar
- ◇ Heavy duty shielded PTO shaft
- ◇ High quality powder-coat paint
- ◇ Cuts at 90° up and 70° down
- ◇ Safety release
- ◇ Ideal for hay or ditch bank mowing
- ◇ Extra cutting blade included

Model	Working	Cutting	HP	Lift Type	Wt. lbs.	Wt. Ship lbs.	List Price
BFT 150	5'	Double	12 - 50	Select Kit	441	491	\$5,130+ Lift Kit
BFS 180	6'	Double	20 - 75	Select Kit	575	625	\$5,675+ Lift Kit
BFS 210	7'	Double	30 - 75	Select Kit	634	684	\$5,795+ Lift Kit
BFS 240H	8'	Double	35 - 75	Hydraulic	673	723	\$7,380
BFS 270H	9'	Double	35 - 75	Hydraulic	711	751	\$7,570

MANUAL AND HYDRAULIC LIFT KITS

R0180-31500	Manual Lift Kit for BFT 150	\$385
R0180-31344	Hydraulic Lift Kit for BFT 150	\$595
R0173-10005	Manual Lift Kit for BFS 180/210	\$390
R0180-31301	Hydraulic Lift Kit for BFS 180/210	\$625

Sickle Bar Mowers are packaged 2 per crate (additional cost if purchased individually)

\$100 net

Prices and specifications subject to change without notice. Check discounts & availability before quoting.
Product Designs May Differ Slightly Than What Appears in the Photographs.

HAY TEDDERS



55 MPH Transport Tires on
19' G6V 570



VORTEX TEDDER

The Enorossi Vortex Hay Tedder comes in the 17', 19', 24', and 32' working widths. All units come standard with hydraulic lift, high-floatation 16" balloon tires, and fender hubs on the inside tires, Universal-Joint rotor style and a heavy 8"x4" rectangular-tube frame. The 19', 24', and 32' tedders come standard with hydraulic tilt.

The newest additions to the lineup are the Professional G6V 740PTH-PRO and G8V 980PTH-PRO. A 6 and 8 basket tedder with heavy transport frame allowing it to quickly fold up and speed from field to field.



U-Joint Engagement on
Rotors



Inside Wheel Fenders
Standard

Specifications:

G4V 520 & G4V 570

- ◇ 17' & 19' Working Widths
- ◇ 3pt Hitch on G4V5203PH
- ◇ Overrunning Ratchet Clutch PTO
- ◇ High Floatation Balloon Tires - 16x650/8
- ◇ High Speed transport tires on G4V 570
- ◇ U-Joint Engagement On Wing Rotors
- ◇ Heavy Built, Rectangular Tube-Frame
- ◇ Wheel Fenders On Inside Tires
- ◇ Standard Hydraulic Lift
- ◇ Standard Hydraulic Tilt On G4V 570 Model (manual crank tilt on 17')

G6V 740

- ◇ 24" Working Widths
- ◇ Overrunning Ratchet Clutch PTO
- ◇ 4 High Floatation Balloon Tires - 16x650/8 on Outside Rotors
- ◇ 2 Tandem Axles on Central Rotors
- ◇ 4 High Floatation Balloon Tires - 18x850/8
- ◇ U-Joint Engagement On Wing Rotors
- ◇ Heavy Built, Rectangular-Tube Frame
- ◇ Wheel Fenders On Inside Tires
- ◇ Hydraulic Tilt & Lift Standard



G6V 740PRO



G6V 740PRO

350/50 R16
Transport Tires



G6V 740PTH

Model	Working Width	Lift Standard	Tilt	Rotors	Min HP	Tine Arms	Tires	Wt. lbs.	List Price
G4V 5203PH	17'	Hydraulic	Mechanical (Hyd. Option)	4	50	24	(4) 16x650/8	1,322	\$10,750
G4V 520PTH	17'	Hydraulic	Mechanical (Hyd. Option)	4	50	24	(4) 16x650/8	1,080	\$8,975
G4V 570PTH	19'	Hydraulic	Hydraulic	4	50	24	(2) 16x650/8 (2) 18x850/8	1,157	\$10,450
G6V 740PTH	24'	Hydraulic	Hydraulic	6	50	36	(4) 16x650/8 (4) 18x850/8	2,160	\$14,750
G6V 740PTH-PRO	24'	Hydraulic	Hydraulic	6	50	36	(4) 16x650/8 (4) 18x850/8	3,938	\$27,385
G8V 980PTH-PRO	32'	Hydraulic	Hydraulic	8	50	48	(8) 16x650/8 (2) 350/50 R16	4,190	\$31,285
OPTIONAL EQUIPMENT									
RO180-34069	Hydraulic Tilt Option for G4V 520PTH								\$925



TAR RIVER



PRZ-5500

Transport Tires w/ hubs:
55 MPH Rating

The Tar River Tedder is built heavy in all the right places, this machine is designed to withstand the rigors of high-volume hay production.

The PRZ-3100 is a 10' tedder with 4"x8" tubing. This unit is a pull-type with a manual tilt and flat-bar tine arms. On the 18' PRZ-5500, large 18" tires give the tedder great floatation across uneven terrain. Adjustable angling allow boundary tedding. Thick-walled tubular tine arms hold up long after the flat bar style ones would have bent. Hydraulic tilt and fold come standard.



Thick-Walled Tubular Tine Arms



Adjustable Angle and Tilt



Hyd. Tilt and Fold



HAY TEDDERS



PRZ-3100

Specifications:

PRZ-3100

- ◇ 10' Working Widths
- ◇ Overrunning Ratchet Clutch PTO
- ◇ High Flotation Tires
- ◇ Heavy Built, Rectangular Tube-Frame

PRZ-5500 (includes all features of PRZ-3100 plus)

- ◇ 18' Working Width
- ◇ Wheel Fenders on Inside Tires
- ◇ Road Transport tires
- ◇ Hydraulic Lift
- ◇ Hydraulic Tilt
- ◇ Heavy-walled tubular arms
- ◇ Integrated Locking collars and hex shaft drive units
- ◇ Double plated rotor supports
- ◇ Adjustable Wheel Yokes—Swivel and Tilt
- ◇ One Hydraulic Remote needed

Model	Working Width	Lift	Tilt	Rotor Style	Rotors/ Arms	Min HP	Tires	Wt. lbs.	List Price
PRZ-3100	10'	N/A	Mech.	N/A	2 / 12	15	(2) 15x600/6	507	\$3,650
PRZ-5500	18'1"	Hyd.	Hyd.	U-Joint	4 / 24	35	(4)18x8.5/8	1,594	\$10,950
10' tedders are packaged 2 per crate (additional cost if purchased individually)									\$100 net



ROTARY

SINGLE AND DOUBLE ROTOR CONFIGURATIONS



Enorossi's Single & Double Rotary Rakes come standard with pneumatic pivoting wheels and heavy, tubular tine arms that are removable for transport. The RR-420 has 11 rotor arms that sweep cleanly all hay types in any condition.

The ENODUO 780 is a center delivery double rotary rake with an adjustable working width from 23' to 25'6". It comes with four wheels per rotor for excellent stability on uneven ground and is semi-mounted with rear steering wheels for maximum maneuverability. The gentle raking action ensures high nutrient levels remain on the crop and in the bale - not in the field.



Tandem Wheel Axles



Heavy Duty, Sealed Oil Bath G-box



Transport Position



Specifications:

- ◇ Extra heavy duty frame and components
- ◇ Hydraulic transport lift standard
- ◇ Heavy-duty, sealed oil bath gearbox
- ◇ Large, high floatation tire
- ◇ Standard tandem axle
- ◇ Removable tine arms
- ◇ Great economic option for those smaller-range tractors and hilly conditions
- ◇ 20" Ground Clearance Hydraulic Lift for transport

RAKES



TRACER 7802

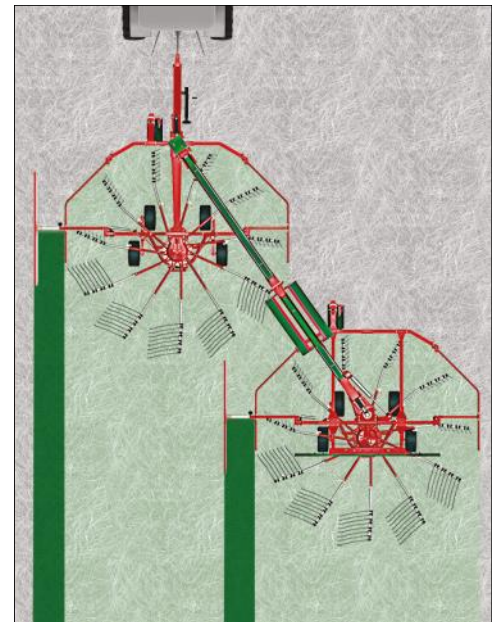

ENODUO 780



Model	Working Width	Lift	Windrow	Min HP	Tine Arms	Tines	Wt. lbs.	Wt. Ship lbs.	List Price
RR350	11'6"	3 Pt	Side	30	9	27	827	867	\$6,825
RR420 EVO PT	13' 9"	Pull-type Hydraulic	Side	30	11	44	1,370	1,470	\$10,915
ENODUO 780	23' - 25'6"	Semi-Mount Hydraulic	Center	70	22	88	3,950	4,400	\$33,225
TRACER 7802	25'6"	Semi-Mount Hydraulic	Side	70	22	88	4,080	4,400	\$39,275

Prices and specifications subject to change without notice. Check discounts & availability before quoting.
 Product Designs May Differ Slightly Than What Appears in the Photographs.

TEDDER RAKE



Enorossi's DR420 –2 Rotor Tedder Rake is ideal for medium-sized and large farms requiring a multifunctional machine. It's the ideal solution for farmers who want to obtain both central and lateral windrows depending on the quantity of the harvested material. It can perform many different tedding and raking functions always with optimal processing of your high-quality forage. Standard equipped with cardan shaft, protections, inverter and twin wheels. The high working speed of almost 10 mph allows outstanding performances.

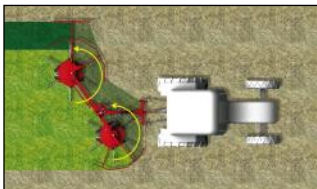

Lateral Windrow

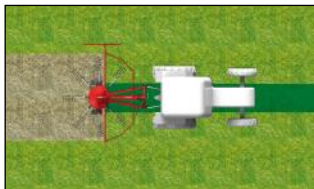

Tedding



Spheroidal cast iron cam and steel rollers.



Twin pivoting wheels

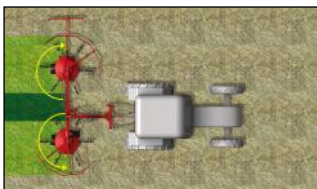

Center Windrow

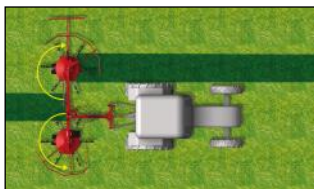

Windrow Turner



Position change from Rake to Tedder

Model	Raking-Width	Tedding-Width	Min HP	Tine Arms	Tines	Wt. lbs.	List Price
DR420	12.1/13.8 ft.	11.1/11.8 ft.	35	12+6	24+18	1104	\$11,550

3 POINT WHEEL RAKE

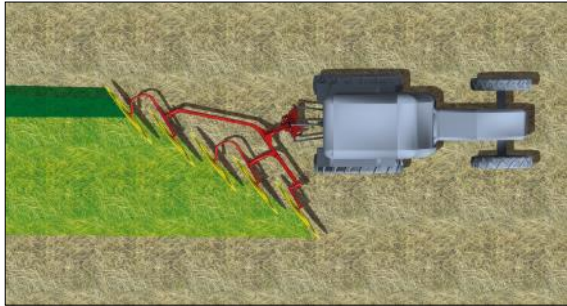

An easy and efficient hay rake suitable for any type of forage. The spring system of the tool holder allows raking wheels to adapt to any type of ground with the correct pressure and without affecting the forage quality. Independent and interchangeable raking wheels mount on tapered roller bearings. Teeth made of flexible steel.



- Specifications:**
- ◇ Heavy tubular frame with strategically placed bracing
 - ◇ Molded steel hubs with tapered roller bearings
 - ◇ 7 mm heavy spring steel teeth
 - ◇ High quality powder-coat paint

RP3C has a specifically designed A-frame for smaller sub-compact tractors.

Perfect tool for windrow turning or raking pine straw.

Model	# Wheels	Teeth per Wheel	Wheel Dia.	Work Width	Wt. lbs.	List Price
RP3C	3	40	55"	6'5" - 7'11"	199 lbs.	\$1,195
RP4	4	40	55"	8'6" - 9'6"	393 lbs.	\$1,650
RP5	5	40	55"	11' 2" - 12'2"	464 lbs.	\$1,975
Rakes are 2 per crate – Both same size (additional cost if purchased individually)						\$100 net

Prices and specifications subject to change without notice. Check discounts & availability before quoting.
Product Designs May Differ Slightly Than What Appears in the Photographs.

CARTED WHEEL RAKE



Unit Shown w/ Optional Center Kicker Wheel



The Enorossi Carted Wheel Rake, with its 15" tires and heavy 6.9 mm teeth, gives you the ability to cruise at high ground speeds with less worries about teeth breakage. Tapered roller bearings keep the wheels running smoothly and easily with minimum maintenance. Frame construction is thick-walled square tubing to give years of reliable service.

Specifications:

- ◇ Heavy square tubing construction on Rake Cart
- ◇ 205/70-15 tires standard
- ◇ Heavy tubular frame with strategically placed bracing
- ◇ Molded steel hubs with tapered roller bearings
- ◇ Optional Kicker wheel available
- ◇ 6.9 mm heavy spring steel teeth
- ◇ Double-action hydraulic cylinder
- ◇ Compact design
- ◇ High quality powder-coat paint

Model	# Wheels	Teeth per Wheel	Wheel Dia.	Work Width	Transport Width	Wt. lbs.	Wt. Ship lbs.	List Price
CADDY 8	8	40	55"	17' 7"	8' 2"	1,324	1,409	\$6,325
CADDY 10	10	40	55"	21'	8' 2"	1,470	1,555	\$6,995
CADDY 12	12	40	55"	24' 3"	8' 2"	1,624	1,709	\$7,995

OPTIONAL EQUIPMENT

R0180-31191	Kicker wheel attachment	\$835
R0180-31090	Select-a-valve (to raise one side only)	\$140

BAT RAKE



HIGH CLEARANCE CARTED RAKE



60" Biggy Rake Wheels
with 7.5 mm Tines Are
Standard!

Raking wheels sit at a
7° angle to create fluffier
windrows and leave less
hay in your fields!

32" Ground Clearance

Enorossi's Bat Rake is the new standard for Hay Rake Caddies. Available in 8, 10 and 12 wheel sizes, the Bat Rake comes in a Single Wheel configuration allowing each individual raking wheel to follow all types of ground contours. Equipped with 60" diameter raking wheels and 7.5 mm tines, the Bat Rake's raking wheels are arguably the best raking wheel on the market today. The heavy spring tines, provide for excellent wear and strong resistance to breakage. The heavy-built frame and high profile of the Bat Rake give a full 32" of ground clearance allowing it to rake in all types of ground contours in heavy hay conditions.

Specifications:

- ◇ Independent rake wheel arms to follow all ground contours
- ◇ High Clearance - 32" of Ground Clearance
- ◇ Perfect for heavy hay
- ◇ Easy windrow width adjustment
- ◇ Heavy built and low maintenance
- ◇ 60" raking wheels with 7.5 mm tines
- ◇ Heavy built and low maintenance
- ◇ 205/70-15 tires standard
- ◇ Heavy tubular frame with strategically placed bracing
- ◇ Molded steel hubs with tapered roller bearings
- ◇ Double-action hydraulic cylinder
- ◇ Compact design

Model	# Wheels	Teeth per Wheel	Wheel Dia.	Max Work Width	Teeth Diameter	Wt. lbs.	Wt. Ship lbs.	List Price
BAT 8-H	8	40	60"	18'5"	7.5 mm	1,445	1,595	\$9,375
BAT 10-H	10	40	60"	21'8"	7.5 mm	1,644	1,794	\$10,125
BAT 12-H	12	40	60"	24'3"	7.5 mm	1,886	2,036	\$11,285

OPTIONAL EQUIPMENT

R0180-32136	Kicker wheel attachment	\$870
R0180-32659	Wind Guard for Rake Wheels (Sold Individually)	\$54

MAXIMUS RAKE

HIGH CAPACITY CARTED WHEEL RAKE



60" Biggy Rake Wheels
with 7.5 mm Tines Are
Standard!

Shown w/ Optional Wind Guards

The MAXIMUS Rake has been designed to match the customer's high demands. It is available in 3 sizes; 12, 14, and 16 wheel configurations. All versions feature independent rake wheel arms using a unique double rod spring system to maintain constant pressure of the raking wheels to the ground. The heavy duty frame and wide tire spacing give great stability in heavy conditions.

Specifications:

- ◇ Independent Rake Wheel Arms to Follow All Ground Contours
- ◇ Perfect for Heavy Hay
- ◇ Easy Windrow Width Adjustment
- ◇ 60" Raking Wheels with 7.5 mm Tines
- ◇ Heavy Duty and Low Maintenance
- ◇ Tandem Tires Standard
- ◇ Heavy Tubular Frame with Strategically Placed Bracing
- ◇ Molded Steel Hubs with Tapered Roller Bearings
- ◇ Optional 2 front/1 rear Kicker Wheel available

Model	# Wheels	Teeth per Wheel	Wheel Dia.	Max Work Width	Teeth Diameter	Wt. lbs.	List Price
M12	12	40	60"	24'	7.5 mm	3,064	\$17,550
M14	14	40	60"	27'	7.5 mm	3,306	\$18,325
M16	16	40	60"	30'	7.5 mm	2,748	\$20,425

OPTIONAL EQUIPMENT

MAX-001	Kicker wheel attachment	\$1,950
R0180-32659	Wind Guard for Rake Wheels (Sold Individually)	\$54
R0180-35861	M14 to M16 wheel conversion kit	\$3,195
R0180-36131	M12 to M14 wheel conversion kit	\$1,340

HIGH CAPACITY EASY RAKE



AGRICULTURAL
MACHINERY

60" Biggy Rake Wheels
with 7.5 mm Tines Are
Standard!



Shown w/ Optional Wind Guards

The Enorossi High Capacity Easy Rake is both easy to assemble and easy to use. Assembly time is typically 1/2 that of other High Capacity Rakes.

The Easy Rake has been designed with a series of innovations that are unique to the market that improves operator productivity. The two sides are independent from one another allowing the machine to operate with a single side. Simple swath adjustment is obtained by a system of easy-to-use bushings.



Specifications:

- ◇ Heavy square tubing construction
- ◇ 205/70-15 tires standard
- ◇ 4 3/4 Heavy tubular frame with strategically placed bracing
- ◇ Molded steel hubs with tapered roller bearings
- ◇ 7.5 mm diameter heavy spring steel teeth
- ◇ Compact design
- ◇ High quality powder-coat paint
- ◇ 40 teeth per wheel
- ◇ 60" Wheel diameter
- ◇ Optional Double Kicker wheel available

Model	# Wheels	Work Width	Qty Tires	Wt. lbs.	List Price
ER 10	10	21' 5"	4	2,870	\$16,105
ER 12	12	24' 4"	4	3,046	\$16,890
ER 14	14	27' 4"	6	3,709	\$19,800
ER 16	16	31' 4"	8	5,180	\$29,160
ER 18SN	18	34' 3"	12	6,945	\$37,240
ER 20SN	20	37' 5"	12	7,385	\$38,510
ER 22SN	22	39' 8"	12	8,050	\$44,320

OPTIONAL EQUIPMENT

R0180-32111	Kicker wheel attachment	\$1,875
R0180-32659	Wind Guard for Rake Wheels (Sold Individually)	\$54

Prices and specifications subject to change without notice. Check discounts & availability before quoting.
Product Designs May Differ Slightly Than What Appears in the Photographs.

BELT RAKE



Two machines in one - rake and ted with the Tar River Implements Belt Rake! With its compact design and versatile functionality, the Belt Rake is an ideal hay tool for the small to medium sized hay producer. Great durability and low maintenance as well as simplicity of use are just a few benefits for this tedder-rake combination Belt Rake.

The D150-3 is a low profile design that can operate with any HP tractor. Simple and easy to use with very low maintenance. The 3 tines per row make clean a sweep of your pasture. Fast adjustments allow one to go from tedding to raking in a breeze.

D180-4 comes standard with 4 double tines per row and all the features of the D150-3. This extra set of tines is helpful in heavier hay crop conditions.



Specifications:

- ◇ Heavy square tubing construction
- ◇ Heavy duty belts for long life
- ◇ Rear Height adjustment wheels
- ◇ Front Pivot wheel



Model	Working Width	# of Belts	Tines x Crossbeam	Weight	List Price
D150-3	71"	2	3	408 LBS	\$3,990
D180-4	83"	2	4	485 LBS	\$4,455

R-Rake



The RR-248 was designed with the needs of the small hay farmer in mind.

With a 98" working width, this rotary rake is capable of delivering an excellent quality of performance while still being compact enough to be used with a 20 HP tractor.

The high-quality but affordable materials make this rake durable and a great choice for budget farms.

With the RR-248's combination of performance, durability, and affordability, it is the next-best-thing for small hay farms.



Model	Working Width	Tine Arms	Tines	Weight	List Price
RR-248	98"	6	12	364 lbs.	\$2,595

MINI ROUND BALER



Perfect for the small farmer who wants to produce their own hay. Low cost and a time saver. The auto twine binding system alerts the operator who simply pushes a button to open the rear door hydraulically, thus dropping the bale. The baler comes with a self-contained hydraulic pump. Only a connection to the tractor's 12V battery and PTO shaft is needed to operate the baler.



Specifications:

- ◇ Twine Baler
- ◇ Bale Size: 20" x 28"
- ◇ Width Pickup: 2' 6"
- ◇ 9600 Polypropylene Baler Twine
- ◇ Replacement Twine
Part #: #MRB850
(available through Parts Dept.)

Model	Bales	Pickup	Tractor HP Min	Working Capacity	Weight	List Price
SRB-870	20" X 28" 35-60 LBS	20" or 30"	18 HP	80-100 Bales per Hour	1,150 lbs.	\$7,555

STATIONARY BALE WRAPPER

Econo-Wrap



Bale Guides To Provide Even Placement of Film Wrap



Film Slicer At The End of Rotary Table Cuts Film After Bale Is Unloaded and New One Is Set Back On For Continuing Operation



Quality Components Such As The Hydraulic Motor & Bevel Gears Ensure Long Machine Life



Too much rain? Try wrapping your hay with the Econo-Wrap Single Bale Wrapper. The Econo-Wrap Bale Wrapper was designed with the average farmer in mind and is ideal for small-scale hay producers. This 3 Pt. Hitch Stationary model will wrap bales up to 4' x 5' round bales.

Specifications:

- ◇ Wraps round bales up to 4'x5' (weighing up to 2,100 lbs.)
- ◇ Hooks up to 3 pt. Hitch and runs off of the auxiliary hydraulics
- ◇ When done wrapping, lift 3 pt. hitch to unload bale
- ◇ Unit is equipped with bale counter
- ◇ Approx. wrap time: 90 seconds



Model	Transport	Film Size	Max. Bale Size	Max. Bale Weight	Min. HP	Weight of Wrapper	List Price
EW-450	3 Pt. Hitch	20" or 30"	4' x 5'	2,100 lbs.	40 HP	1,091 lbs.	\$5,375
OPTIONAL EQUIPMENT							
EW-001A	Vertical Bale Positioner EW-450						\$580

Prices and specifications subject to change without notice. Check discounts & availability before quoting.
Product Designs May Differ Slightly Than What Appears in the Photographs.

SELF-LOADING BALE WRAPPER

Econo-Wrap



Upgrade your baling operation with the Econo-Wrap EW-1800TA, a streamlined wrapper designed for solo operators. With the ability to wrap bales up to 4' x 5', this fully automated machine requires only one button push to initiate the wrapping process.

Effortlessly fit the bale into the lifting arm cradle, press the button and watch as the EW-1800TA takes over—lifting the bale onto its turntable and beginning the automatic wrapping process. Enjoy the freedom to drive up to the next bale while the machine continues wrapping, dumping it only when fully finished.

The Econo-Wrap EW-1800TA is the perfect partner for your baling needs.



Specifications:

- ◇ Wraps round bales up to 4'x5' (weighing up to 2,425 lbs.)
- ◇ Fully automated electronic control allows user to select from 3 cycles (Automatic, Semi-Automatic or Manual)
- ◇ Side tip damper standard
- ◇ Unit is equipped with bale counter
- ◇ 3 film roll holders

Model	Transport	Film Size	Max. Bale Size	Max. Bale Weight	Min. HP	Weight of Wrapper	List Price
EW-1800TA	Trailer-Type	20" or 30"	4' x 5'	2,425lbs.	45 HP	4,520 lbs.	\$26,515

INLINE BALE WRAPPER



Eliminate the rush of baling hay for threat of an oncoming storm. Reduce the amount of waste at feeding time, improve your hay harvest efficiency and reduce loss in harvest and storage. Accomplish all of this with the KEMCO Inline Bale Wrapper, the fastest wrapper on the market, which wraps up to 4 bales per minute. As fast as you put them up, they will be wrapped!



Model	# of Plastic Dispensers	Type of Bales	Wrapping Width	Remote Steering	Engine	Self-Propel Drive	Film Sensor	Hyd. Tailgate Lift	LED Lights	Weight (lbs.)	List Price
MODEL 355											
KEMCO 355 PRO 2	3	Round / Square	6'6" Round / 5'6" Square	Yes	20 HP	Dual Wheel	Std	Std	2	6,320	Call for Pricing

Prices and specifications subject to change without notice. Check discounts & availability before quoting.
Product Designs May Differ Slightly Than What Appears in the Photographs.

SIDE SHIFT ROTARY TILLER



Specifically designed and engineered for sub-compact tractors in the 15-25 Horsepower range, the Tar River DLT Series Rotary Tiller is built with 4 blades per flange and a sturdy #80 chain drive system to give you years of reliable service. The Slip-Clutch PTO protection comes standard.

Available in 42" and 50" working widths, the Tar River DLT Series Rotary Tiller is perfect for all your small-tractor tilling needs.

DLT Series



Specifications for DLT Series:

- ◇ #80 Chain Drive Transmission
- ◇ 4 Blades Per Flange
- ◇ PTO with Slip-Clutch Protection
- ◇ Solid A-Frame
- ◇ Side-Shift Standard
- ◇ 4" Tilling Depth

Model	Working Width	Blades per flange	Drive	HP	Wt. lbs.	Shipping Wt. lbs.	List Price
SUB-COMPACT SERIES							
DLT-S42	42"	4	#80 Chain	15 - 25	304	375	\$1,725
DLT-S50	50"	4	#80 Chain	15 - 25	348	429	\$1,835

COMPACT ROTARY TILLER



Built to fit the needs of the compact tractor market, the Tar River TXG Series Rotary Tiller will work great at tilling up your small garden plots. It comes standard with a “gear-to-gear” drive system, 6 blades per flange and Slip-Clutch PTO protection.

Available in 41”, 48” and 59” working widths, the Tar River TXG Series Rotary Tiller is perfect for all your small-tractor tilling needs.

TXG Series



Specifications for TXG Series:

- ◇ Gear Drive Transmission
- ◇ 6 Blades Per Flange
- ◇ PTO with Slip Clutch
- ◇ Powder Coat Paint
- ◇ Solid A Frame
- ◇ 6” Tilling Depth



Model	Working Width	Blades per flange	Drive	HP	Wt. lbs.	Shipping Wt. lbs.	List Price
COMPACT SERIES							
TXG-040	41”	6	Gear	15-30	337	392	\$1,985
TXG-050	48”	6	Gear	15-30	374	434	\$2,045
TXG-060	59”	6	Gear	18-30	412	477	\$2,155

Prices and specifications subject to change without notice. Check discounts & availability before quoting.
Product Designs May Differ Slightly Than What Appears in the Photographs.

MEDIUM DUTY ROTARY TILLER



Using quality components that are made to last, the YCT Series Rotary Tiller by Tar River Implements is built heavily enough to handle your tilling needs and for the price, it can cut through the competition.

Engineered for tractors from 30 to 60 Horsepower, the Tar River YCT Series Rotary Tiller comes with 6 blades per flange, slip clutch PTO protection and gear drive side transmission. It is available in 4', 5', 5.5', 6' and 7' models.

With its sleek and heavy design, paired with the quality components and its incredible price, the Tar River Rotary Tiller is ahead of its class.

YCT Series



**5 Year
Gearbox
Warranty
Limited**



Specifications for YCT Series

- ◇ Gear Drive Transmission
- ◇ 6 Blades Per Flange
- ◇ PTO with Slip Clutch
- ◇ Powder Coat Paint
- ◇ Solid A Frame
- ◇ Large Diameter Rotor
- ◇ Labyrinth Rotor Bearing Shielding
- ◇ 7" Tilling Depth

Model	Working Width	Blades per flange	Drive	HP	Wt. lbs.	Shipping Wt. lbs.	List Price
MEDIUM DUTY SERIES							
YCT-050	49"	6	Gear	30 - 50	525	554	\$2,545
YCT-060	58"	6	Gear	30 - 50	542	608	\$2,710
YCT-066	66"	6	Gear	35 - 50	596	669	\$2,995
YCT-074	72"	6	Gear	40 - 50	640	718	\$3,125
YCT-082	81"	6	Gear	45 - 60	702	757	\$3,470

REVERSE ROTATION MD ROTARY TILLER



Tar River Implements is proud to provide the YCT-R Series Reverse Rotation Rotary Tiller. Reverse Rotation tillers provide a cleaner and smoother finish in less passes than a forward rotation tiller. These tillers will cut the overlying growth and bury them under the surface.

Engineered for tractors from 30 to 60 Horsepower, the Tar River YCT-R Series Rotary Tiller comes with 6 blades per flange, slip clutch PTO protection and gear drive side transmission. It is available in 5' and 6' working widths.

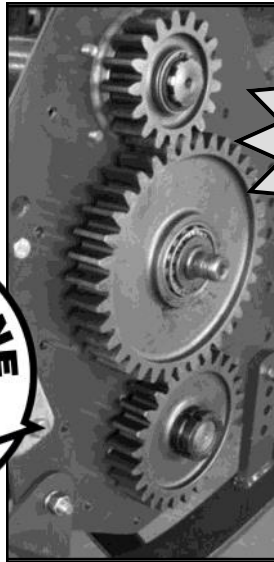

**5 Year
Gearbox
Warranty
Limited**



YCT-R Series

Specifications for YCT-R Series:

- ◇ Gear Drive Transmission
- ◇ 6 Blades Per Flange
- ◇ PTO with Slip Clutch
- ◇ Powder Coat Paint
- ◇ Solid A Frame
- ◇ Large Diameter Rotor
- ◇ Labyrinth Rotor Bearing Shielding
- ◇ Front Dirt Shield
- ◇ 7" Tilling Depth

Model	Working Width	Blades per flange	Drive	HP	Wt. lbs.	Shipping Wt. lbs.	List Price
REVERSE TINE MEDIUM DUTY SERIES							
YCT-R60	58"	6	Gear	30 - 50	557	623	\$2,960
YCT-R74	72"	6	Gear	40 - 50	654	734	\$3,375

Prices and specifications subject to change without notice. Check discounts & availability before quoting.
Product Designs May Differ Slightly Than What Appears in the Photographs.

HEAVY DUTY ROTARY TILLER



Built to suit the needs of larger tractors and more agricultural applications, the Tar River RXT Series Rotary Tiller is rated for up to 120 HP tractors. Using spiral center gearbox gears, extra thick rotor assembly and a tough A-frame, the RXT tiller can handle your roughest jobs.

Available in working widths of 66", 73", 84 and 92".

RXT Series



Specifications for RXT Series:

- ◇ Gear Drive Transmission
- ◇ 6 Blades Per Flange
- ◇ PTO with Slip Clutch
- ◇ Powder Coat Paint
- ◇ Large Diameter Rotor
- ◇ Solid A Frame
- ◇ Waterproof Rotor Supports
- ◇ 8" Tilling Depth

Model	Working Width	Blades per flange	Drive	HP	PTO Driveline	Wt. lbs.	Shipping Wt. lbs.	List Price
HEAVY DUTY SERIES								
RXT-072	66"	6	Gear	50-120	Series 6 S/C	945	1,053	\$4,835
RXT-080	73"	6	Gear	55-120	Series 6 S/C	970	1,075	\$5,050
RXT-088	85"	6	Gear	60-120	Series 6 S/C	1,015	1,121	\$5,365
RXT-096	92"	6	Gear	65-120	Series 6 S/C	1,069	1,183	\$5,505

HD MULTI-SPEED GEARBOX ROTARY TILLER



Built heavy for agricultural applications, the Tar River CXT Series Rotary Tiller is rated for tractors up to 130 HP and available in working widths of 86", 95, 104", 112" and 121".

The CXT tillers are designed with multispeed gearboxes to handle your ever changing conditions. The multi-speed gearbox is designed for easy gear access to allow the rotor speed to be changed quickly as you move to different field conditions. A large thick walled rotor is sustained by water proof rotor supports for wet conditions. Decks are double layered to keep stone indentations to a minimum.

**5 Year
Gearbox
Warranty
Limited**



CXT Series

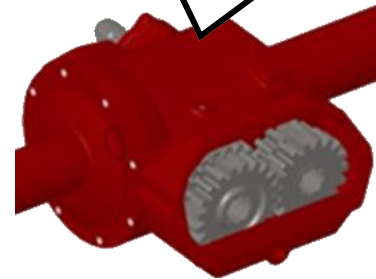
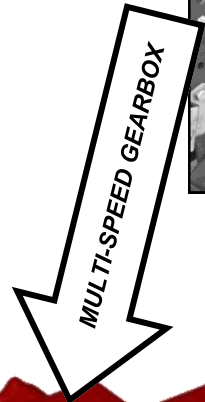
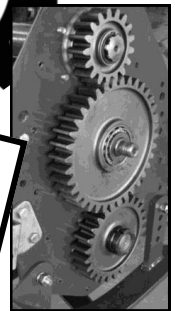

Specifications for CXT Series:

- ◇ Gear Drive Transmission
- ◇ 6 Blades Per Flange
- ◇ PTO with Slip Clutch
- ◇ Powder Coat Paint
- ◇ Spiral Gears
- ◇ Large Diameter Rotor
- ◇ Solid A Frame
- ◇ Waterproof Rotor Supports
- ◇ 10" Tilling Depth

Model	Working Width	Blades per flange	Drive	HP	PTO Driveline	Wt. lbs.	Shipping Wt. lbs.	List Price
CXT-086	86"	6	Gear	60-130	Series 8 S/C	1,636	1,735	\$8,230
CXT-095	95"	6	Gear	70-130	Series 8 S/C	1,762	1,862	\$8,475
CXT-104	104"	6	Gear	75-130	Series 8 S/C	1,876	1,895	\$9,425
CXT-112	112"	6	Gear	80-130	Series 8 S/C	2,081	2,317	\$10,635
CXT-121	121"	6	Gear	85-130	Series 8 S/C	2,115	2,410	\$11,335

Prices and specifications subject to change without notice. Check discounts & availability before quoting.
Product Designs May Differ Slightly Than What Appears in the Photographs.

Tar River Implements offers an economical solution to your seeding needs.

The DRL-048 & DRL-072 come with double opening discs to plant grass, corn, beans, oats and more. The seeder comes equipped with two stainless steel boxes with closeable slides for each row. Apply fertilizer to each row while planting. The DLR is designed to be used as a secondary tillage tool.

Ground conditions need to be worked up or tilled prior to use.



Model	Working Width	Working Depth	Min HP Req	Front Cup/ Rear Cups	Spacing	Double Disc openers	Cat. Hitch	Weight	List Price
DRL-048	49"	3/4" - 2"	15	7+7	6"	7 Sets	1	569 Lbs.	\$3,595
DRL-072	70"	3/4" - 2"	20	10 + 10	6"	10 Sets	1 & 2	625 Lbs.	\$3,970

CONVENTIONAL DRILL



FOR USE IN PREPARED GROUND



Specifications:

- ◇ 6" Spacing
- ◇ Spring Loaded Double Disc Opener
- ◇ Disc Scrapers
- ◇ Divided Stainless Steel Hopper
- ◇ Standard Seed/Fertilizer seed cups on front and rear
- ◇ Full width Cage Roller
- ◇ Compaction scrapers
- ◇ Rear Roller
- ◇ DRL-048 Hopper Capacity: 3.50 Cu. Ft. Front Hopper
2.50 Cu. Ft. Rear Hopper
- ◇ DRL-072 Hopper Capacity: 5.00 Cu. Ft. Front Hopper
4.00 Cu. Ft. Rear Hopper



TAR RIVER

The SAYA507 is an 78" cost effective Light Duty No Drill with front coulter package.

10 Swept-back spring loaded coulters make seeding easy and economical. Large seed and Legume cups allows for precise seeding in a no-till operation. Stainless steel hoppers prevent rust and keep your drill in fine working shape for years to come.



Model	Working Width	Working Depth	Min HP Req	Front Cup/Rear Cups	Spacing	Double Disc openers	Cat. Hitch	Weight	List Price
SAYA-505	55"	3/4" - 2"	30	7	7.5"	7 Sets	1 & 2	1,036 Lbs.	\$6,210
SAYA-507	78"	3/4" - 2"	35	10	7.5"	10 Sets	1 & 2	1,400 Lbs.	\$7,930

NO-TILL DRILL



SAYA—Light Duty No-Till Drill For use in Light No-Till Applications

Specifications:

- ◇ 7.5" Spacing
- ◇ Spring-Loaded Coulters discs
- ◇ Spring-Loaded Double Disc Opener with Cast Iron Hubs
- ◇ Cast Iron Swept-back Disc carriers
- ◇ Disc Scrapers
- ◇ Divided Stainless Steel Hopper
- ◇ Standard Seed/Fertilizer seed cups on front
- ◇ Legume Seed cups on rear
- ◇ Full width Cage Roller
- ◇ Compaction scrapers
- ◇ SAYA-505/507 – Front Hopper Capacity: 4.00/5.5 Cu. Ft.
- ◇ SAYA-505/507 – Rear Hopper Capacity: 3.00/4.5 Cu. Ft.



GREENSCAPE

MODEL 750-2



High Precision Large Seedcup



Smaller Legume Seedcup



The Greenscape 750 No-Till Drill is the latest in the Greenscape family of the most reliable seeders produced in the US over the past 20 years.

High precision seed boxes and flow control make seeding a breeze with the ability to drill many different varieties and sizes of seed into all types of planting conditions. Heavy built, but constructed to be able to be handled by tractors as low as 50 HP, the 750-2 is designed for planting deer food plots around woodlands or high precision pasture seeding in the fall.

The 10 coulters at 7 1/2" and high-precision large seed seedcups accurately drop seeds into the openings. A separate Legume Seedbox with high precision seed cups accurately drop seed along a "splash pan" that rains the small seed over the soil.

A packer roller system with Nylon rings or optional cast iron rollers help press the seed into the ground and close up the cuts made by the disc openers.

Specifications:

- ◇ Three Point Hitch Cat. 1&2
- ◇ Heavy tubular frame construction
- ◇ All ground driven, no PTO shaft or gearbox to maintain
- ◇ Precise seed metering cups with individual clean out gates
- ◇ Rear roller packer rings to firm and smooth seedbed
- ◇ Water tight seed box with agitator shaft - calibration chart and seeding rate chart
- ◇ 10 Cast Iron double disc openers spaced at 7.5"
- ◇ Spring loaded coulters to cut through tough ground
- ◇ Optional Cast Iron roller rings

NO-TILL DRILL



Simple & Highly Accurate Fluted Seedcup Adjustment System

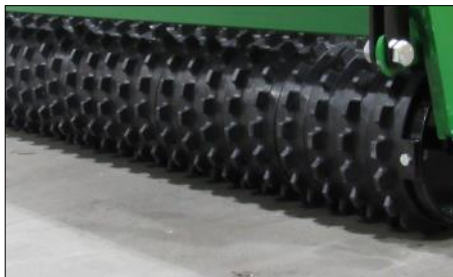

Nylon Corrugated Cultipacker Rings
Optional Cast Iron



Shearpin for Seedcup Safety



High Precision Ground Drive Seeding System.



Model	Description	Weight (lbs.)	Ship Wt.	List Price
750-2	78" No-Till Drill with Large Seed and Precision Legume Seedbox	1,840	1,990	\$12,580
OPTIONAL EQUIPMENT				
GSC-024	Cast Iron Rings			\$750

Prices and specifications subject to change without notice. Check discounts & availability before quoting.
Product Designs May Differ Slightly Than What Appears in the Photographs.



GREENSCAPE

The Greenscape represents a totally new concept in seeding. Being neither a grain drill nor a PTO driven seeder, the Greenscape effectively prepares the soil, drops and lightly covers the seed, and then firmly presses the soil for a perfectly prepared seedbed. It is designed to achieve a perfect pattern across the working width of the machine; no row effect as with drills or knife type over seeders.

Ground driven – no PTO shafts or gearboxes to maintain, and requires only a 35 HP (50 HP on 84” model) tractor to operate. When equipped with the optional precision small seed box and Native Seed box the Greenscape will plant virtually any type or size seed at any rate.

This machine will seed into all conditions, including primary seeding into prepared ground or overseeding into existing vegetation. Available in 60” and 84” working widths.

Specifications:

- ◇ Three Point Hitch Cat. 1&2
- ◇ Heavy tubular frame construction
- ◇ All ground driven, no PTO shaft or gearbox to maintain
- ◇ Precise seed metering cups with individual clean out gates
- ◇ Rear roller packer rings to firm and smooth seedbed
- ◇ Water tight seed box with agitator shaft - calibration chart and seeding rate chart
- ◇ Driven spiked rollers crumble soil just enough for perfect seed-to-soil contact
- ◇ Exclusive Torque Arm - keeps constant adjustable down pressure on rear cultipacker
- ◇ Broadcast across full width of working area - no row effect as with PTO driven, knife type machines or sod drills

Benefits:

- ◇ High ground speed – up to 7 MPH
- ◇ Full width broadcast coverage
NO ROW EFFECT
- ◇ Seed or overseed in any condition
 - Fields
 - Groomed Turf
 - Prepared ground
- ◇ Abrasive-Resistant mining steel tines for extremely high wear
- ◇ Front Roller aggressively drives second roller 42% faster
- ◇ High quality – High precision seed cups for precise seed distribution
- ◇ Seed disengagement system for aeration & Seedcup safety shear pin
- ◇ Reinforced Nylon or Cast Iron corrugated roller rings
- ◇ Quick Hitch compatible reinforced three-point (Cat 1 & 2)
- ◇ Available Hoppers
 - Standard Large-Seed Box
 - Precision Legume Seed box
 - Native Grass Seed Box
 - Stainless Steel Fertilizer box

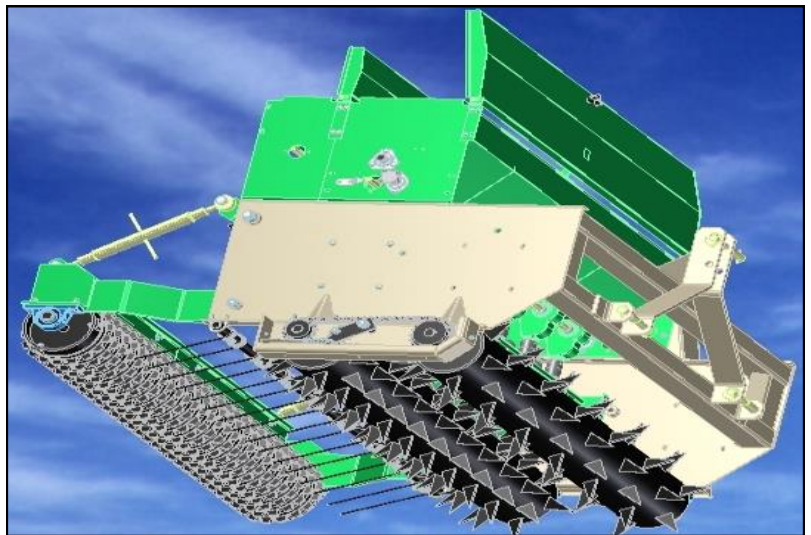

Front Pulverizer Bar



Seeder with 3 Boxes

CONSERVATION SEEDER



MODEL 600



MODEL 840

Model	Description	60" Model	Wt. Lbs.	Ship Wt.	List Price
600-1	60 Inch Base Unit with 1 large-grass Seed box		1,325	1,545	\$8,480
600-2	60 Inch Base Unit with 1 large-grass Seed box + 1 Precision Legume Seed box		1,380	1,600	\$9,975
600-3	60 Inch Base Unit with 1 large-grass Seed box + 1 Precision Legume Seed box + 1 Stainless Steel Fertilizer Hopper		1,490	1,710	\$13,405
600-4	60 Inch Base Unit with 1 large-grass Seed box + 1 Precision Legume Seed box + 1 Native Grass Seed box		1,557	1,710	\$12,905
600-5	60 Inch Base Unit with 2 large-grass Seed boxes + 1 Precision Legume Seed box		1,545	1,710	\$12,420
Model	Description	84" Model	Wt. Lbs.	Ship Wt.	List Price
840-1	84 Inch Base Unit with 1 large-grass Seed box		1,960	2,210	\$13,060
840-2	84 Inch Base Unit with 1 large-grass Seed box + 1 Precision Legume Seed box		2,084	2,334	\$14,940
840-3	84 Inch Base Unit with 1 large-grass Seed box + 1 Precision Legume Seed box + 1 Stainless Steel Fertilizer Hopper		2,315	2,565	\$18,950
840-4	84 Inch Base Unit with 1 large-grass Seed box + 1 Precision Legume Seed box + 1 Native Grass Seed box		2,409	2,659	\$18,660
840-5	84 Inch Base Unit with 2 large-grass Seed boxes + 1 Precision Legume Seed box		2,315	2,565	\$17,900

OPTIONAL EQUIPMENT:

Model	Description	List Price
GSC-001	Cast Iron Rings - 600 Model	\$565
GSC-004	Cast Iron Rings - 840 Model	\$795
GSC-003	Rear roller scraper - 600 Models Nylon	\$195
GSC-005	Rear roller scraper - 840 Models Nylon	\$255
GSC-007	Rear roller scraper - 600 Models Cast Iron	\$195
GSC-006	Rear roller scraper - 840 Models Cast Iron	\$255
GSC-016	Road Light Kit - All Models	\$390
GSC-018	60" Floating Front Double Pulverizer Bar	\$1,710
GSC-017	84" Floating Front Double Pulverizer Bar	\$1,910

Prices and specifications subject to change without notice. Check discounts & availability before quoting.
Product Designs May Differ Slightly Than What Appears in the Photographs.

CHAIN HARROWS

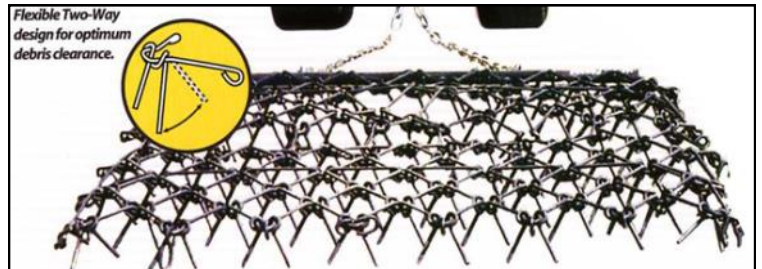

DRAG HARROWS—BARS ONLY

Model	Description	Recommended Sections	Weight	List Price
24-110487	4' Bar	ONE 4' x 4' section	22 lbs.	\$115
24-110488	6' Bar	ONE 6' x 8' section	33 lbs.	\$155
24-110489	8' Bar	TWO 4' x 8' sections	43 lbs.	\$195
24-110490	10' Bar	TWO 10' x 4' sections	54 lbs.	\$255
24-110491	12' Bar	TWO 6' x 8' sections	64 lbs.	\$295

DRAG HARROWS—SECTION ONLY

24-202111	4' x 4' x 1/2" chain	75 lbs.	\$275
24-202112	4' x 8' x 1/2" chain	133 lbs.	\$500
24-202113	6' x 8' x 1/2" chain	216 lbs.	\$765
24-202114	10' x 4' x 1/2" chain	179 lbs.	\$695
24-202115	10' x 8' x 1/2" chain	358 lbs.	\$1,335



Photo shows lift, drawbar, and sections. Sold Separately.

3—POINT FRAMES (Carrying frame only. Drawbar and Sections *NOT INCLUDED*)

Model	Description	Weight	List Price
BHL6/8	6'/8' 3-Pt. Mounted Harrow Lift	144 lbs.	\$1,150
BHL10	10' 3-Pt. Mounted Harrow Lift	150 lbs.	\$1,250
BHL12	12' 3-Pt. Mounted Harrow Lift	180 lbs.	\$1,450

ATV HARROWS—COMPLETE

ATV4	4' ATV Mini Harrow	105 lbs.	\$515
ATV6	6' ATV Mini Harrow	165 lbs.	\$750

1/2" MATERIAL ON ALL HARROWS

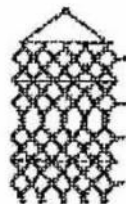

4 FT. CONFIGURATION
24-110487 - 4' DRAWBAR
24-202112 - 4'x8' SECTION

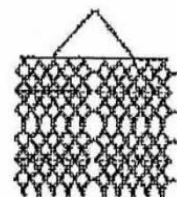

8 FT. CONFIGURATION
24-110489 - 8' DRAWBAR
(2) 24-202112 - 4'x8' SECTIONS

CARTED CHAIN HARROWS



Dethatch dead growth and rejuvenate grass and pasture fields with the Tar River Carted Harrow. Available in 20' and 24' working widths, the heavy 5/8" harrow tines keep your pasture healthy and vibrant.

The sturdy design of the Tar River Carted Harrow which easily folds into transport position makes it the obvious choice for your pasture renovation needs.

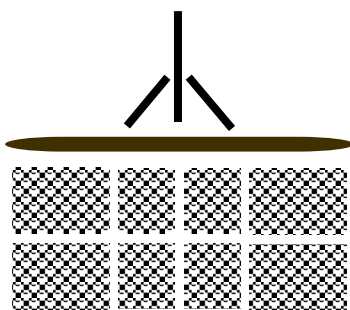

20' Carted Harrow

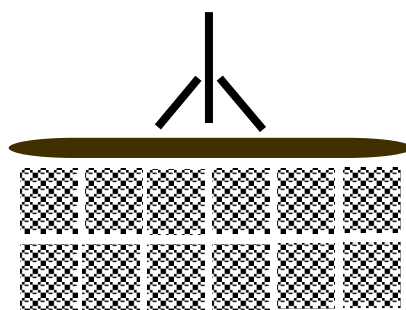

24' Carted Harrow



Model	Description	Center Sections	Wing Sections	Wing Fold	List Price
CH-20	20' Carted Harrow	2 each 4' x 6' x 5/8" chain	1 each 6' x 6' x 5/8" chain	Hydraulic	\$11,950
CH-24	24' Carted Harrow	2 each 4' x 6' x 5/8" chain	2 each 4' x 6' x 5/8" chain	Hydraulic	\$12,750

CAST IRON PASTURE HARROW



Take care of your pasture fields and horse arenas with the Tar River WH13 or WH20 Cast Iron Pasture Harrow.

Cat. 1 3 point hitch compact design make it easy to hook up and store. The reversible cast iron tines and the heavy tubular design will give you years of use.



Specifications

- ◇ Heavy Duty pipe frame
- ◇ Cat 1 3 Point w/Cat.2 Bushings
- ◇ Cat 1 QH adaptable
- ◇ Cast Iron Star tines
- ◇ Reversible
- ◇ Distributes and pulverizes manure, seed bed prep, renovate pastures, horse arenas, ballfields, levels mole hills, etc.

Model	Description	Tines	Fold	Transport Width	Weight	List Price
WH13	13' Pasture Harrow	Cast Iron	Manual	7'3"	507 lbs.	\$2,175
WH20	20' Pasture Harrow	Cast Iron	Hyd.	7'3"	811 lbs.	\$3,950

Prices and specifications subject to change without notice. Check discounts & availability before quoting.
 Product Designs May Differ Slightly Than What Appears in the Photographs.

FINISHING MOWERS



Keep your grassy areas looking good with the 100 Series Economy Finishing Mower by Tar River Implements. These mowers are great for compact tractors maintaining home estates and light landscaping.

Built for those more demanding jobs, the 500 Series Professional Series Finishing Mower by Tar River Implements have a sleek design and are built heavy to withstand years of hard work. Get closer to those hard to reach spots with the rounded deck and get a nice clean cut every time with the rear discharge design.



Specifications:

- ◇ Solid Rubber Tires
- ◇ Rear Discharge
- ◇ Floating Hitch
- ◇ Easy Cutting Height Adjustment
- ◇ Easy Belt Tension Adjustment
- ◇ Powder Coat Paint
- ◇ Category 1 Hitch
- ◇ Economy Series standard with chain guards
- ◇ BFM-507 Standard with Anti-scalp roller

Model	Working Width	Overall Width	HP	Number of Blades	Grass Discharge	Tires	Ship Weight	List Price
ECONOMY SERIES								
BFM-105	58"	59"	15-30	3	Rear Discharge	Solid Rubber	435 lbs.	\$1,755
BFM-106	71"	72"	15-30	3	Rear Discharge	Solid Rubber	544 lbs.	\$2,135
PROFESSIONAL SERIES								
BFM-505	60"	64"	20-40	3	Rear Discharge	Solid Rubber	581 lbs.	\$2,675
BFM-506	72"	75"	30-50	3	Rear Discharge	Solid Rubber	625 lbs.,	\$3,050
BFM-507	84"	87"	40-50	3	Rear Discharge	Solid Rubber	836 lbs.	\$3,730
OPTIONAL EQUIPMENT								
BFM-501	Anti-Scalp Roller Kit (Standard on BFM-507)							\$180

3 PT. FLAIL MOWERS



Tar River Implements offers three versions of flail mowers.

Sub Compact version for tractors 25 HP and under, a Compact model version for 45 HP tractors and a Heavy-Duty model available in a center mount or a hydraulic offset version for 60 Hp tractors. In cutting widths from 53" to 87", the Tar River flail mowers are ready to take care of all your mowing needs.

TREF SERIES—LIGHT DUTY



TRMF SERIES—MED. DUTY



FLM SERIES—HEAVY DUTY

Specifications:

- ◇ Cat. 1 and Cat. 1&2 hitch on Offset Models
- ◇ Powder Coat Paint
- ◇ Heavy Cast Hammer Knives
- ◇ 3 & 4 Belt drive configurations
- ◇ Adjustable Height Control Rear Roller

Model	Working Width		HP	Weight	List Price
SUBCOMPACT & COMPACT FLAIL MOWERS					
TREF-053	53"		15-25	453 lbs.	\$2,480
TREF-061	61"		20-25	485 lbs.	\$2,590
TRMF-061	61"		25-45	670 lbs.	\$3,030
TRMF-077	77"		30-45	756 lbs.	\$3,540
HEAVY DUTY MOWERS					
FLM-180	71"	CENTER MOUNT	30-60 HP	922 lbs.	\$4,455
FLM-220H	87"	15.75" HYDRAULIC OFFSET	30-60 HP	1,060 lbs.	\$5,375

Prices and specifications subject to change without notice. Check discounts & availability before quoting.
Product Designs May Differ Slightly Than What Appears in the Photographs.

FLAIL MOWERS



GARDEN Series

- ◇ Maintain grass areas with the ORSI Garden series flail mowers.
- ◇ Perfectly designed for small compact tractors. All units come equipped with Self-cleaning Roller, Counter Knife, and Free-Wheel Protection integrated inside the gearbox.
- ◇ Available in 51" and 59" working widths.

FRUIT EXTRA Series

- ◇ Professional Mower for heavy brush cuttings and maintaining grass and cuttings in orchards or other areas where heavy cutting is needed.
- ◇ 1/4" Hardox frame holds up to punishing and pounding delivered in adverse conditions.
- ◇ Hydraulic Side shift allows the mower to be offset up to 20"



Model	HP	Working Width	Wt. Lbs.	Cutting Capacity	Blades	Belts	List Price
3 POINT FLAIL MOWER—GRASS							
GARDEN 130	18-35	51"	440	5/8"	"Y"	3	\$3,185
GARDEN 150	20-35	59"	485	5/8"	"Y"	3	\$3,375
3 POINT FLAIL MOWER—ORCHARD							
FRUIT EXTRA 180	60-130	71"	1,841	3 1/4"	Hammer	4	\$11,940

DITCH BANK MOWERS



The Tar River hydraulic offset pivoting ditch bank mower is the ideal machine to maintain ditches or embankments around your property. Hook up to the standard 3 point like a normal flail mower that is pulled directly behind the tractor, but when in the full operating position, it will mow up to 90° down and up to 35°. All models come standard with heavy hammer knives and a perfectly balanced rotor for a smooth operation.

Specifications:

- ◇ Cat. 1&2 hitch
- ◇ Powder Coat Paint
- ◇ Heavy Cast Hammer Knives



- ◇ 3 & 4 Belt drive configurations
- ◇ Adjustable Height Control Rear Roller

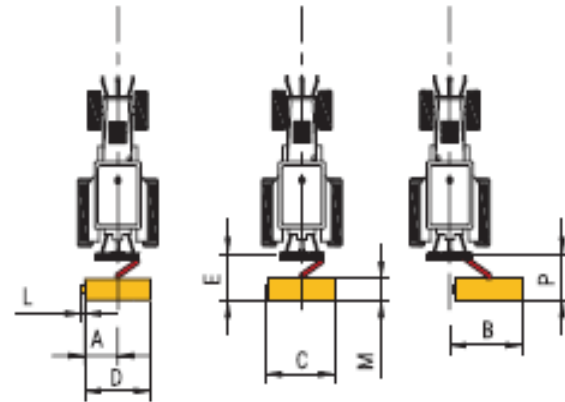
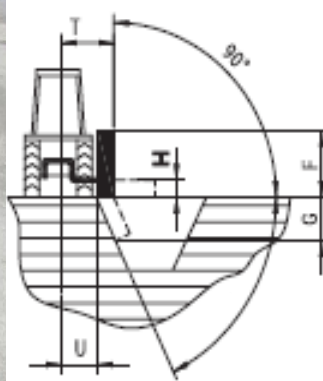

All measurements in Inches

TRDB-053

MODEL	A	B	C	D	E	F	G	H	L	M	P	ANGLE UP	ANGLE DOWN
TRDB-053	17	70	59	54	64	77	20	28	5	32	61	90°	30°
TRDB-061	17	78	67	62	64	85	24	28	5	32	61	90°	30°
TRBD-069	18	98	77	69	69	93	26	30	6	37	71	90°	35°

Model	Working Width	Cutting Angle	MIN HP	Weight	List Price
LIGHT AND MEDIUM DUTY DITCH BANK MOWERS					
TRDB-053	53"	90° Up & 30° Down	30	664 lbs.	\$3,795
TRDB-061	61"	90° Up & 30° Down	35	697 lbs.	\$3,990
TRDB-069	69"	90° Up & 35° Down	45	1,002 lbs.	\$5,370

Prices and specifications subject to change without notice. Check discounts & availability before quoting.
Product Designs May Differ Slightly Than What Appears in the Photographs.



DITCH BANK



ENERGY SERIES

Ditch bank mower for the smaller compact tractors with HP ratings from 20-50 HP. Popular sizes of 51" and 61" working widths make the Energy series ditch bank mower a "must have" for small farms that need to keep up mowing around ponds and ditches. The Energy ditch bank mower comes with a self-cleaning roller, counter knife, and free-wheel protection integrated inside the gearbox. A safety and self levelling breakaway system is a standard feature. Cat 1 hitch

YOUNG SERIES

If you need 65 inches of cut, then the YOUNG series is the mower for you. Heavy frame and gearbox for tractors up to 65 HP.

3 Year warranty on the cast iron components, self cleaning roller, counter knife and free-wheel protection inside the gearbox.

Hammer knives hold up under harsh conditions.

Cat 1 hitch



COMPETITION GS SERIES

The heavy duty COMPETITION GS Series is built tough for commercial applications. Double thick HARDOX (AR400 Equivalent) frame will hold up to the punishment for cutting road sides as well as ponds and ditch banks. 3 Year warranty on the cast iron components, self cleaning roller, counter knife and free-wheel protection inside the gearbox. Internal rotor bearings are protected from most impacts. Double-tapered roller bearings keep it rolling much longer than pillar block bearings. Comes standard with DOUBLE WIDE ANGLE PTO SHAFT.

Cat 2 hitch

MOWERS

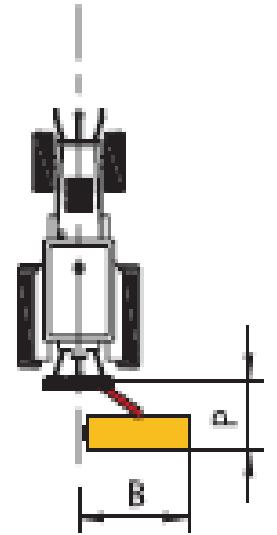
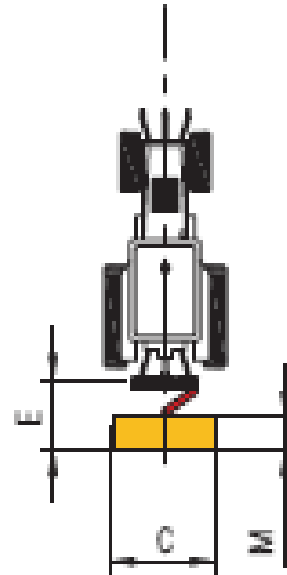
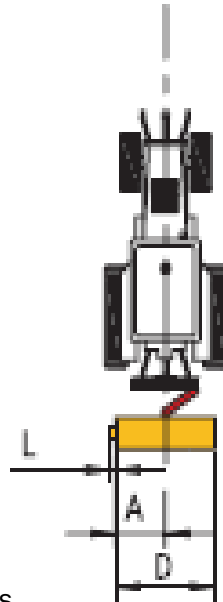
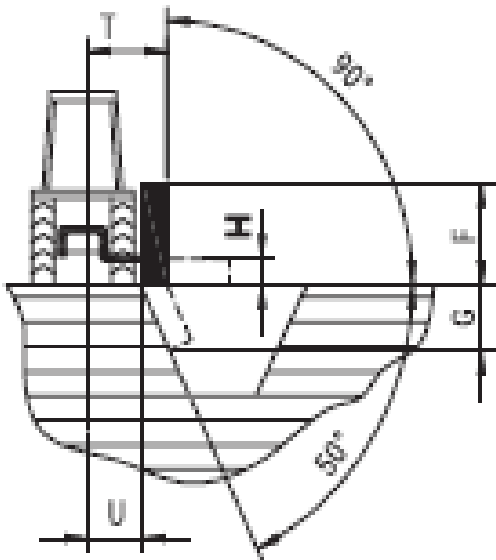

All measurements in Inches

	A	B	C	D	E	F	G	H	L	M	P	S	T	U
Energy 130	28	73	55	52	41	55	41	12	3	20	51	19	48	29
Energy 155	28	82	64	61	41	64	50	12	3	20	51	19	48	29
Young 165	33	83	70	64	63	97	48	17	6	28	76	19	59	35
Competition GS 180	32	109	81	71	72	108	52	19	9	39	80	24	70	51
Competition GS 200	32	117	89	79	72	116	59	19	9	39	80	24	70	51

Model	HP	Work Width	Wt. Lbs.	Cutting Capacity	Blades	Belts	List Price
ENERGY SERIES							
Energy 130	20-35	51"	511	1"	"Hammer"	3	\$6,320
Energy 155	20-50	61"	562	1"	"Hammer"	3	\$6,925
YOUNG SERIES							
Young 165	35-65	65"	1,047	1"	"Hammer"	4	\$10,560
COMPETITION GS SERIES							
Competition GS 180	50-80	71"	1,609	2 1/4"	"Hammer"	4	\$13,770
Competition GS 200	50-80	79"	1,653	2 1/4"	"Hammer"	4	\$14,310

Prices and specifications subject to change without notice. Check discounts & availability before quoting.
Product Designs May Differ Slightly Than What Appears in the Photographs.

HYDRAULIC BOOM



Tractor Range	28-75 HP
MIN Tractor Weight	1,800 lbs.
Cutting Head	39" Sickle Head
MAX Reach	11' 11"
Arm Tubing	100 x 80 x 4
Hitch	Cat. 1&2
Machine Weight	419 lbs.
MIN Oil Flow	4 GPM
Controls	Lever

MODEL	HP	Tractor Min. Wt.	Std. Head Inches	Controls	Wt. Lbs.	List Price
HEDGE 160	20-75	1,800	39"	Lever	418	\$9,390

MOWERS



029

CUT REVERS

GARDENING SERIES



15 - 50 HP



Tractor Range	15-50 HP
MIN Tractor Wt.	1,800 lbs.
Cutting Head	32" Flail w/ Hammers
MAX Reach	10' 3"
Arm Tubing	80 x 80 x 4
Hitch	Cat. 1
Machine Weight	683 lbs.
Controls	Lever

MODEL	HP	Tractor Min. Wt.	Std. Head Inches	Controls	Wt. Lbs.	List Price
CUT 029	16-35	1,800	32"	Lever	682	\$17,595

HYDRAULIC BOOM



RIVER COMPACT

AGRICULTURAL SERIES



25 - 60 HP



Tractor Range	25-60 HP
MIN Tractor Weight	River Compact 355: 3,300 lbs. River Compact 420: 4,000 lbs.
Cutting Head	River Compact 355: 41" Flail Mower with Hammers or 41" Rotary River Compact 420: 41" Flail Mower with Hammers or 41" Rotary
MAX Reach	River Compact 355: 11' 4" River Compact 420: 13' 11"
Arm Tubing	100 x 80 x 5
Hitch	Cat. 1&2
Machine Weight	River Compact 355: 1135 lbs. River Compact 420: 1312 lbs.
Annual Use	Up to 250 hours
Controls	Lever

MODEL	Hours per year	HP	Tractor Min. Wt.	Std. Head Inches	Controls	Wt. Lbs.	List Price
RIVER COMPACT 355	250	25-55	3,300	41"	Lever	1133	\$19,125
RIVER COMPACT 420	250	25-55	4,000	41"	Lever	1309	\$20,450

MOWERS



RIVER COMPACT PLUS

AGRICULTURAL SERIES



Tractor Range	50-100 HP
MIN Tractor Weight	River Compact Plus 450: 4,000 lbs. River Compact Plus 580: 4,900 lbs.
Cutting Head	41" Flail Mower with Hammers or 41" Rotary
MAX Reach	River Compact Plus 450: 14' 8" River Compact Plus 580: 19' 2"
Arm Tubing	100 x 80 x 5
Hitch	Cat. 1&2
Machine Weight	River Compact Plus 450: 1477 lbs. River Compact Plus 580: 1676 lbs.
Annual Use	Up to 400 hours
Controls	Easy-Tronic Joystick



MODEL	Hours per year	HP	Tractor Min. Wt.	Std. Head Inches	Controls	Wt. Lbs.	List Price
RIVER COMPACT Plus 450	400	50-90	4,000	41"	Joystick	1474	\$24,420
RIVER COMPACT Plus 580	400	50-90	4,900	41"	Joystick	1672	\$26,950

Prices and specifications subject to change without notice. Check discounts & availability before quoting.
Product Designs May Differ Slightly Than What Appears in the Photographs.

HYDRAULIC BOOM



PERFORMANCE

AGRICULTURAL SERIES



60 - 110 HP



Tractor Range	60-110 HP
MIN Tractor Weight	4,200 lbs.
Cutting Head	49" Flail Mower with Hammers or 41" Rotary
MAX Reach	14' 11"
Arm Tubing	120 x 100 x 5
Hitch	Cat. 2
Machine Weight	1808 lbs.
Annual Use	Up to 400 hours
Controls	Easy-Tronic Joystick

EASY-TRONIC



MODEL	Hours per year	HP	Tractor Min. Wt.	Std. Head Inches	Controls	Wt. Lbs.	List Price
PERFORMANCE 455	400	45-100	4,200	49"	Joystick	1804	\$29,355

MOWERS



PERFORMANCE PARALLELOGRAM

AGRICULTURAL SERIES



60 - 110 HP



Tractor Range	60-110 HP
MIN Tractor Weight	5,100 lbs.
Cutting Head	49" Flail Mower with Hammers or 41" Rotary
MAX Reach	16' 7"
Arm Tubing	120 x 100 x 5
Hitch	Cat. 2
Machine Weight	1907 lbs.
Annual Use	Up to 400 hours
Controls	Easy-Tronic Joystick

EASY-TRONIC



MODEL	Hours per year	HP	Tractor Min. Wt.	Std. Head Inches	Controls	Wt. Lbs.	List Price
PERFORMANCE P510	400	45-100	5,100	49"	Joystick	1903	\$34,365

Prices and specifications subject to change without notice. Check discounts & availability before quoting.
Product Designs May Differ Slightly Than What Appears in the Photographs.

HYDRAULIC BOOM



PERFORMANCE PARALLELOGRAM VISUAL

AGRICULTURAL SERIES



70 - 110 HP



Tractor Range	70-110 HP
MIN Tractor Weight	5,100 lbs.
Cutting Head	49" Flail Mower with Hammers or 41" Rotary
MAX Reach	16' 7"
Arm Tubing	120 x 100 x 5
Hitch	Cat. 2
Machine Weight	1907 lbs.
Annual Use	Up to 400 hours
Controls	Easy-Tronic Joystick

EASY-TRONIC



SINGLE MOVEMENTS



MODEL	Hours per year	HP	Tractor Min. Wt.	Std. Head Inches	Controls	Wt. Lbs.	List Price
PERFORMANCE P510 Visual	400	45-100	5,100	49"	Joystick	1903	\$38,700

MOWERS

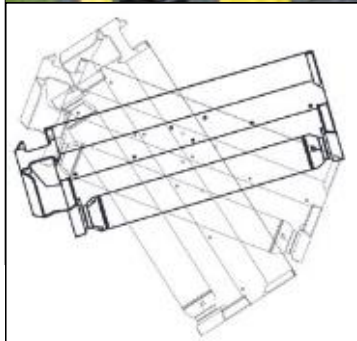

	Hours per year	HP	Tractor Min. Wt.	Std. Head Inches	Controls	Wt. Lbs.
HEDGE 160	-	20-75	1,800	39"	Cable	418
CUT 029	-	16-35	1,800	32"	Cable	682
RIVER COMPACT 355	250	25-55	3,300	41"	Cable	1133
RIVER COMPACT 420	250	25-55	4,000	41"	Cable	1309
RIVER COMPACT Plus 450	400	50-90	4,000	41"	Joystick	1474
RIVER COMPACT Plus 580	400	50-90	4,900	41"	Joystick	1672
PERFORMANCE 455	400	45-100	4,200	49"	Joystick	1804
PERFORMANCE P510	400	45-100	5,100	49"	Joystick	1903
PERFORMANCE P510 Visual	400	45-100	5,100	49"	Joystick	1903

Prices and specifications subject to change without notice. Check discounts & availability before quoting.
 Product Designs May Differ Slightly Than What Appears in the Photographs.



ROTARY



Designed to help dealers compete with the big box stores, Tar River Implements introduces the ERC Rotary Cutters. These mowers have front & rear chains standard, are built for 20-55 HP tractors and have a 5 Year Gearbox Warranty (1 year on the rest). They come with shear pin or slip-clutch PTOs, cut capacity of 1 1/2", pan-type stump jumpers and in working widths of 4', 5' and 6'.

Only available in yellow.

Specifications:

- ◇ 45 HP Gearbox
- ◇ Shear Pin PTO on 4' - Slip Clutch on 5' & 6'
- ◇ 4' - 12 GA Deck
- ◇ 5' - 11 GA Deck
- ◇ 6' - 9 GA Deck
- ◇ Cat. 1 Hitch w/ Floating Top Link
- ◇ 1 1/2" Cutting Capacity
- ◇ Laminated Wheels & Re-greaseable Hubs
- ◇ Pan Stump Jumper
- ◇ Safety Chain Shields Standard

Model	Working Width	PTO Protection	Min. HP	Weight	List Price
ERC-4	48"	Shear-Pin	20	411 lbs.	\$1,595
ERC-5SC	60"	Slip Clutch	25	499 lbs.	\$1,920
ERC-6SC	72"	Slip Clutch	35	734 lbs.	\$2,620

OPTIONAL EQUIPMENT

COM-147650	Slip Clutch Option for ERC-4	\$125
------------	------------------------------	-------

CUTTERS



Tar River Implements introduces the MRC and HRC Rotary Cutters. These mowers have front & rear chains standard, are built for 30-75 HP tractors and have a 5 Year Gearbox Warranty. They come with slip-clutch PTOs and a cut capacity of 2"

Specifications:

- ◇ 75 HP Gearbox
- ◇ Cat. 1 Hitch w/ Floating Top Link
- ◇ 2" Cutting Capacity
- ◇ Laminated Wheels & Re-greaseable Hubs
- ◇ Solid Stump Jumper
- ◇ 7" Sides MRC-6 8" Sides HRC-7
- ◇ Deck Thickness 3mm & 5mm
- ◇ Replaceable Skids
- ◇ Safety Chain Shields Standard
- ◇ Cat.1 MCR-6 Cat.2 HDR-7
- ◇ MRC-5 one tailwheel & HRC-7 two tail wheels

Model	Working Width	PTO Protection	Min. HP	Tail Wheels	Weight	List Price
MRC-6	72"	Slip Clutch	35-90	1	725 lbs.	\$2,995
HRC-7	84"	Slip Clutch	45-90	2	1,375 lbs.	\$3,975

Prices and specifications subject to change without notice. Check discounts & availability before quoting.
Product Designs May Differ Slightly Than What Appears in the Photographs.



FERTILIZER

3-POINT



High-quality spreaders with special heat-treated paint that resists rust. Easy and quick assembly, available in Poly and Steel hoppers.

Specifications:

- ◇ Cat.1 three point hitch
- ◇ Dependable Gearbox
- ◇ Fixed Agitator (Optional Roller Wheel Agitator)
- ◇ Sturdy Metal Hopper With Special Heat-Treated Paint To Resist Rust
- ◇ Poly hopper with Stainless steel bottom and spreading fins

Model	Capacity lbs.	Capacity Cu. Ft	Hopper Height	Spread Swath	Weight lbs.	List Price
STEEL HOPPER						
SSS-300	716	11.5	40"	46'	115	\$825
SSS-500	1,058	18	46"	46'	133	\$875
POLY HOPPER WITH STAINLESS STEEL BOTTOM AND FINS (PLASTIC ON SSC MODEL)						
SSC-100	224	3.6	31"	23'	83	\$765
SP-300SS	716	11.5	42"	46'	127	\$925
SP-500SS	1,121	17	46"	46'	135	\$975
OPTIONAL EQUIPMENT						
ARS-12	Roller Wheel Agitator (not available for SSC model)					\$75
	Spreader Assembly (6 = free assembly)					\$25 (dealer net)

SPREADERS

PULL-TYPE



Optional Deflector Shield



Built with steel gears, this ground drive unit will hold up to the rigors of your everyday needs. Adjustable tow bar allows the spreader to be used on a multiple hitch height configurations. High floatation tires on a wide base give greater stability over many types of terrain.

Specifications:

- ◇ Heavy duty steel gears in gearbox
- ◇ Adjustable towing hitch
- ◇ High floatation tires
- ◇ Powder coated frame and hopper or Poly hopper
- ◇ Left - center - right spread pattern
- ◇ Optional spread deflector shield available
- ◇ 13" x 6" Tires on PTS-100
- ◇ 16 1/2" x 8" on PTS-160

Model	Capacity lbs.	Capacity Cu. Ft.	Spread Swath	Hopper	Hopper Height	Tires	Wt. lbs.	List Price
PTS-100	225	3.7	20'	Metal	40'	13" x 6"	75	\$630
PTS-100P	225	3.7	20'	Poly	40'	13" x 6"	70	\$715
PTS-160	360	5.3	20'	Metal	44'	16 1/2" x 8"	82	\$825
PTS-160P	360	5.3	20'	Poly	44'	16 1/2" x 8"	76	\$935
OPTIONAL EQUIPMENT								
PTS-001	Deflector Shield							\$75
PTS-002	Cable Gate Opener Extension							\$285
	Spreader Assembly							\$25 (dealer net)



FERTILIZER

COMPACT SIDE SHOT



Designed for precise spreading of fertilizer and salt or sand. The material shoots out of the sides making it a perfect tool for winery/vineyards, blueberry farms, Christmas tree farms or anywhere else precise application is necessary.

“Side-Shot” components can be removed to use the spreader as any typical 3-Point mounted Fertilizer Spreader.

Specifications:

- ◇ Designed for spreading fertilizer and salt
- ◇ Category 1 & 2 Hitch
- ◇ Stainless Steel Bottom
- ◇ Material shoots out of both left and right sides
- ◇ Standard Grate Filter & Hydraulic Lever Control for Spreader Gate

Model	Max Capacity	Spread Swath	Unit Dimensions (H x W)	Weight	List Price
SR-600	1,719 lbs.	26' - 59'	38" x 51"	229 lbs.	\$2,785
SR-800	2,204 lbs.	26' - 59'	40" x 55"	264 lbs.	\$2,975

OPTIONAL EQUIPMENT

SR-002	Kit for 180 Degree Spread	\$160
--------	---------------------------	-------

SPREADERS

PENDULAR



Designed to provide excellent precision while at the same time being versatile enough to spread materials with different weights, textures, and sizes as well as high-moisture materials (up to 30% moisture content) such as powdered fertilizer.



Unit Dimensions (H x W x L)

45" x 46.5" Dia.

38" x 59" x 59"

47" x 59" x 59"

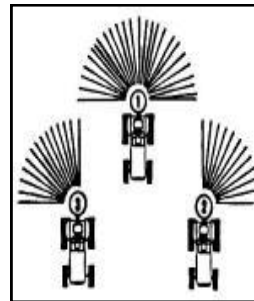

3 Possible
Spread Patterns

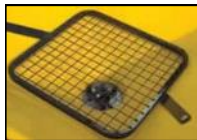

Model	Max Capacity	Spread Swath		Wt. Lbs.	List Price
SPT0-350	795 lbs.	39' - 46'	16' - 19'	203	\$2,475
SQTF-600	1,402 lbs.	39' - 46'	16' - 19'	322	\$3,125
SQTF-1000A	2,645 lbs.	39' - 46'	16" - 19"	344	\$3,595

OPTIONAL EQUIPMENT

SQTF-001	Salt & Sand Chute	\$185
SQTF-002	Rubber Chute Insert	\$70
SQTF-003	Hydraulic Lever Control	\$420
SQTF-004	Agitator Extension	\$95
SQTF-005	Grate Filter	\$165

Prices and specifications subject to change without notice. Check discounts & availability before quoting.
Product Designs May Differ Slightly Than What Appears in the Photographs.

LANDSCAPE RAKES

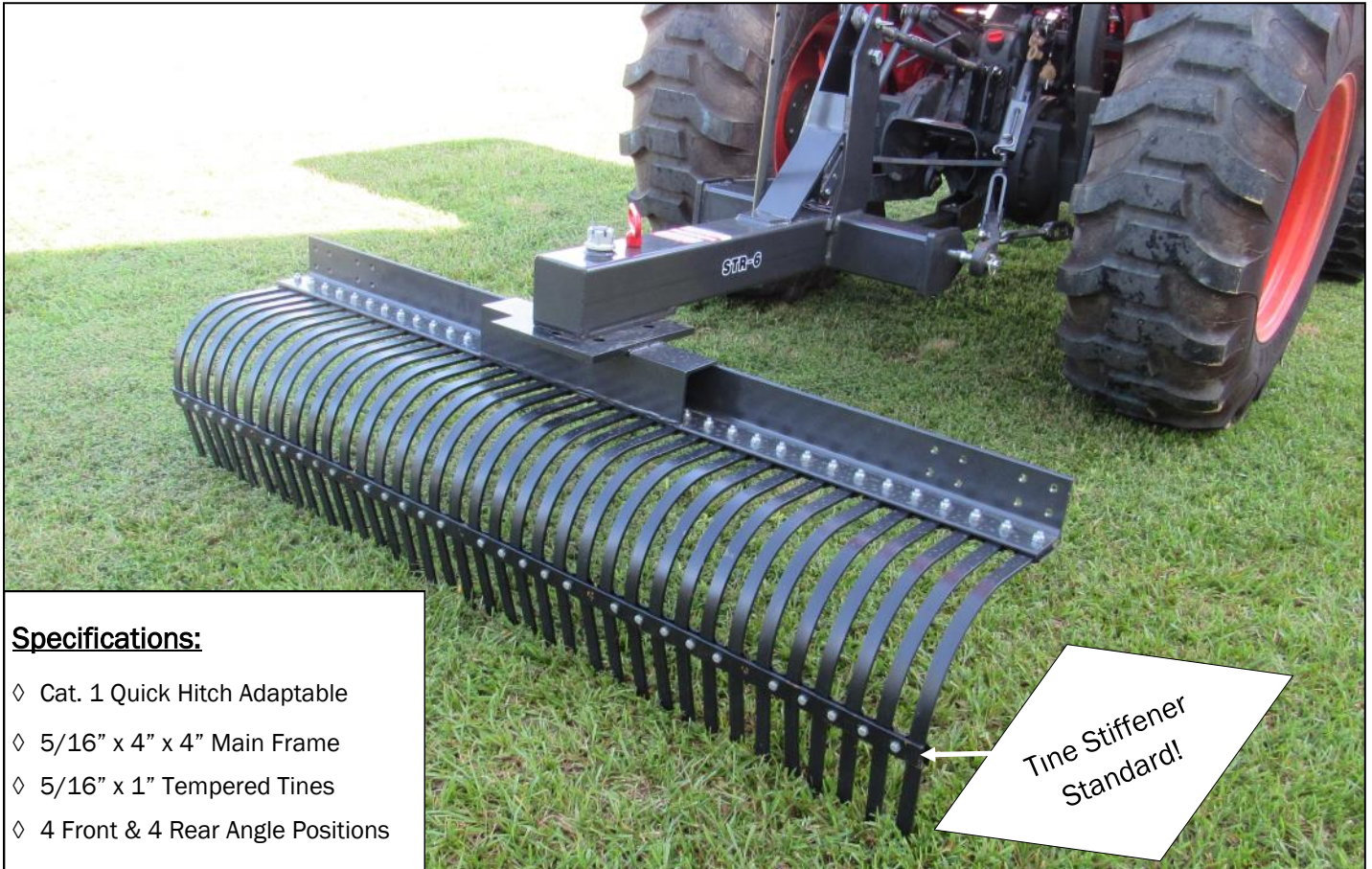

Specifications:

- ◇ Cat. 1 Quick Hitch Adaptable
- ◇ 5/16" x 4" x 4" Main Frame
- ◇ 5/16" x 1" Tempered Tines
- ◇ 4 Front & 4 Rear Angle Positions

Tine Stiffener Standard!

Add the finishing touch to your yard or work space. The Tar River Implements STR Series Landscape Rake is available in 4' - 8' working widths to fit most tractor needs. Tine stiffener comes standard.

Model	Working Width	HP Range	Weight	List Price
STR-4	48"	18-45	242 lbs.	\$1,115
STR-5	60"	20-45	291 lbs.	\$1,240
STR-6	72"	25-45	348 lbs.	\$1,330
STR-7	84"	30-45	395 lbs.	\$1,460
STR-8	96"	35-45	448 lbs.	\$1,650

REAR BLADES



**BRB-2
STD. DUTY**



**BRB-9
HVY. DUTY**



Hydraulic Angling
Cylinder Comes
Standard on BRB-9
Series

**BRB-5
MED. DUTY**

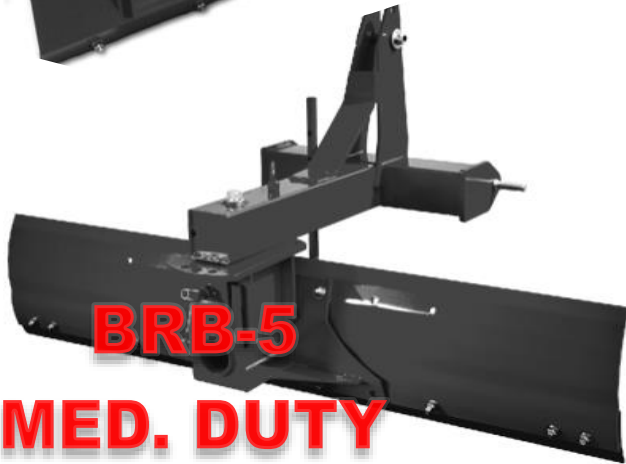

Tar River Implements offers a full line of rear blades to fit your needs. From the Light Duty 60" blade for simple grading jobs all the way up to the 6-way Heavy Duty with Hydraulic Tilt, Angle and Offset in an 9' version for your toughest jobs.

Model	Working Width	M.Board Height	M.Board Thickness	M.Board Offset	M.Board Angle & Tilt	Max HP	Weight lbs.	List Price
STANDARD DUTY ECONOMY* - UP TO 40 HP - TILT & ANGLE								
BRB-205	60"	14"	1/4"	N/A	Yes	40	190	\$690
BRB-206	72"	14"	1/4"	N/A	YES	40	216	\$795
MEDIUM DUTY ECONOMY - UP TO 60 HP - TILT, ANGLE & OFFSET								
BRB-506	72"	13"	1/4"	Yes	Yes	60	333	\$1,335
BRB-507	84"	13"	1/4"	Yes	Yes	60	355	\$1,395
BRB-508	96"	13"	1/4"	Yes	Yes	60	377	\$1,455
6-WAY HEAVY DUTY - UP TO 90 HP - TILT, HYD. ANGLE & OFFSET								
BRB-907	84"	19"	1/4"	Yes	Yes	90	908	\$2,795
BRB-908	96"	19"	1/4"	Yes	Yes	90	939	\$3,225
BRB-909	108"	19"	1/4"	Yes	Yes	90	979	\$3,405
OPTIONAL EQUIPMENT								
BRB-009HC	Hydraulic Cylinder Kit for Tilt (on BRB-9 Series)							\$525

DISC HARROWS



DHS-SERIES

The DHS models are designed for 25-50 hp tractors. All units have adjustable gang angles and are Category 1 & 2 quick hitch compatible. 18" notched blades are standard. The main frame is constructed of heavy duty 2 3/8" square tubing. The gangs have a 1" square high strength axle with re-greaseable flange bearings.

Model	Cutting Width	Spacing	Disc Size	# Discs	HP	Weight Lbs.	List Price
DHS-4818	4'	7 1/2"	18"	12	25-35	630 lbs.	\$2,425
DHS-6018	5'	7 1/2"	18"	16	35-45	818 lbs.	\$2,785
DHS-7418	6'2"	7 1/2"	18"	20	45-50	904 lbs.	\$3,165
DHS-9020	7' 6"	9"	18"	20	50-60	970 LBS.	\$3,475

CULTIPACKER



Tar River Implements now has four sizes of Cultipackers available for your landscaping needs. Designed for 18-40 hp tractors. They are made with a 2" square tube main frame. The packer wheels are 9 1/2" cast iron steel. Category 1 quick hitch compatible.

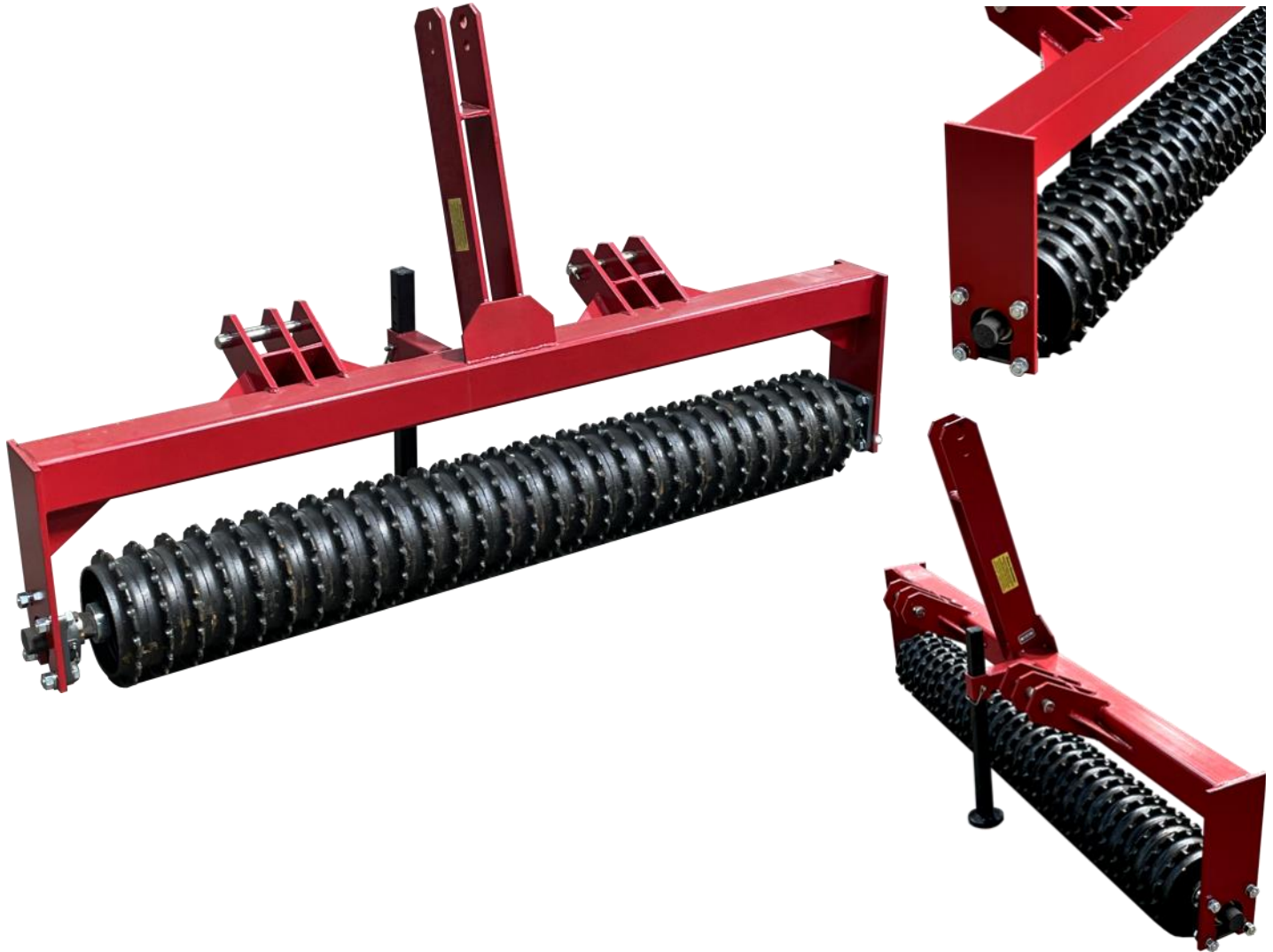

Model	Working Width	HP	Weight	List Price
CP-48L	48"	18-40	364 lbs.	\$1,955
CP-60L	60"	18-40	439 lbs.	\$2,175
CP-72L	72"	18-40	509 lbs.	\$2,425
CP-84L	84"	18-40	578 lbs.	\$2,725

Prices and specifications subject to change without notice. Check discounts & availability before quoting.
Product Designs May Differ Slightly Than What Appears in the Photographs.

SHANK CULTIVATOR



The Tar River Implements Spring Loaded Cultivators are available in three sizes. They come in 36", 54" and 72" working widths and are made using 3/8" Steel angle iron with 3/4" wide shanks.

Specifications:

- ◇ Suitable for stone and root filled soil, light, and medium soil conditions
- ◇ Used for loosening and aerating soil up to 9 inches below the surface
- ◇ Prepares seedbeds quickly and economically
- ◇ When one tine strikes a hidden obstruction the others continue to work at the correct depth.
- ◇ Strength derived from heavy duty shanks, which once fixed to the frame cannot move or strain out of position
- ◇ Shovel to Shovel Distance 15"
- ◇ Height 21"

Model	Spring	Tines	Total Length	Working Width	Tractor Power (HP)	Weight (lbs.)	List Price
SLC-5	3/8" x 50"	3/8" x 2 1/2"	50"	36"	15-45	260	\$1,155
SLC-7			68"	54"	30-45	396	\$1,520
SLC-9			86"	72"	40-45	482	\$1,795

**The weight and working data contained in the present creative are supplied for information only and are not binding. Specification and size can be altered as part of ongoing product modification/improvement.*

BOX BLADES



Tar River Implements has Box Blades available in five popular sizes. The New Sub-Compact Box Blades come in 48" & 60" working widths and 1/4" side plates. The Medium Duty Box Blades come in 2 designs and in 60", 72", 84", and 96" working widths with 1/2" side plates (3/8" for 60" model). With its clevis hitches and durable design, the Tar River Box Blade is a great tool for all around dirt maintenance.

The front and rear replaceable 6" scraper blades allow for quick and easy replacement making the Tar River line of box blades an excellent choice for all your dirt moving needs!



Specifications:

- ◇ Sub-Compact available in 48" & 60" working widths
- ◇ Medium-Duty available in 60", 72", 84" & 96" working widths
- ◇ Clevis Hitch & Quick-Hitch Compatible
- ◇ Category 1 Hitch on 4,5 & 6. Cat 1&2 on 7 & 8 foot.
- ◇ 72", 84" & 96" models come with 1/2" side plates
- ◇ Heavy Duty A-Frame on BBXD Series

Model	Working Width	Side Plate Thickness	A-Frame Thickness	# Shanks	Max HP	Weight Lbs.	List Price
SUB-COMPACT MODELS							
BB4SC	48"	1/4"	1/2"	4	24	343 lbs.	\$990
BB5SC	60"	1/4"	1/2"	5	24	390 lbs.	\$1,055
MEDIUM DUTY MODELS							
BB5	60"	3/8"	1/2"	5	50	502 lbs.	\$1,215
BB6	72"	1/2"	1/2"	6	50	548 lbs.	\$1,485
HEAVY DUTY MODELS							
BBXD7	84"	1/2"	1/2"	7	60	639 lbs.	\$1,695
BBXD8	96"	1/2"	1/2"	8	60	730 lbs.	\$1,915

Prices and specifications subject to change without notice. Check discounts & availability before quoting.
Product Designs May Differ Slightly Than What Appears in the Photographs.

LAND LEVELER



Shanks are
STANDARD

Tar River Implements is proud to introduce the LB Series Land Leveler available in 3 popular sizes. These sturdy built units are great for a variety of applications from landscaping to work around the farm or homestead. Because they are not designed to move dirt, a lower HP tractor can use these.

Scarifier shanks and grading blades are multi-adjustable.

Specifications:

- ◇ Cat. 1 Quick Hitch Adaptable
- ◇ Clevis Hitch
- ◇ Adjustable Grading Height & Ripping Shanks
- ◇ Replaceable Skid Shoes

Model	Working Width	Max HP	Weight	List Price
LB4	48"	50	455 lbs.	\$1,655
LB5	60"	50	589 lbs.	\$1,940
LB6	72"	50	700 lbs.	\$2,190
LB7	84"	50	759 lbs.	\$2,395

POST HOLE DIGGER



Tar River Implements introduces the BPH-100 3pt Post Hole Digger. Equipped with a Category 1 hitch and an 18-60 HP rated gearbox. Three choices of augers, BPH-06A is a 6", BPH-09A is a 9" and the BPH-12A is a 12".

Model	Description	HP	Hitch	Weight	List Price
POST HOLE DIGGER					
BPH-100	Post Hole Digger	18-60	Cat 1	157 lbs.	\$1,075
AUGERS					
BPH-06A	6" Auger			24 lbs.	\$160
BPH-09A	9" Auger			35 lbs.	\$190
BPH-12A	12" Auger			49 lbs.	\$265

Packaged 2 per crate sizes can be mixed (additional cost if purchased individually)

Prices and specifications subject to change without notice. Check discounts & availability before quoting.
Product Designs May Differ Slightly Than What Appears in the Photographs.



TRACTOR

Sub-Soiler / Middle Buster

- ◇ Cat. 1 Hitch
- ◇ Powder Coat Paint
- ◇ Adjustable Ripping/Digging Depth
- ◇ Heavy-Duty Steel Frame with Ripper Tooth (Sub-Soiler) and 14" Middle Buster

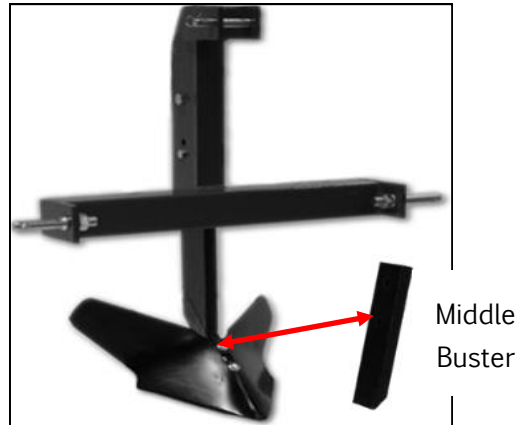

Middle Buster

Hiller/Ripper

- ◇ Heavy Duty Construction (HKC1)
- ◇ Adjustable Row Width

**A-HKC1 - Ripper Accessory sold separately

List Price — \$75

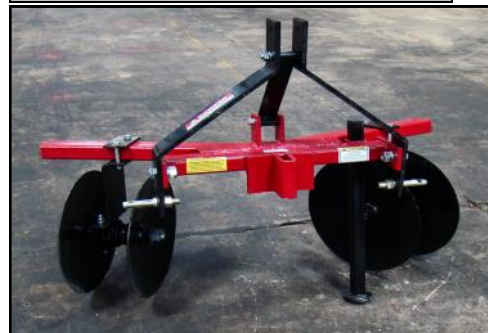

1 & 2 Bottom Plows

- ◇ 1 Bottom Plow (PB1) with a 14" Bottom
- ◇ 2 Bottom Plow (PB2) with 16" Bottoms



3 Pt. Bale Spear

- ◇ Standard 49" Spear
- ◇ 2,000 lb. Capacity
- ◇ Cat. 1 Hitch Pins



Model	Description	Hitch	Misc. Info	Weight	List Price
BSM-100	Sub-Soiler / Mid Buster Combo	Cat. 1	n/a	79/88 lbs.	\$320
HKC1	Hiller/Ripper	Cat. 1	n/a	192 lbs.	\$1,055
PB1	1 Bottom Plow	Cat. 1	14" Bottom	186 lbs.	\$1,055
PB2	2 Bottom Plow	Cat. 1	16" Bottoms	279 lbs.	\$2,050
TPS1	Bale Spear - 3 Pt. Mount	Cat. 1	2,000 lb. Cap.	85 lbs.	\$425

TOOLS



Quick-Hitch Adapters

- ◇ Attach To Tractor For Quick & Easy Hook-Up For 3-Pt Implements
- ◇ Category 1 (QH1) or Category 2 (QH2) Adapters Available

Trailer Mover

- ◇ Designed to Move Empty Trailers with the Tractor's 3-Pt Hitch
- ◇ Category 1 Hitch (TM1&TM2)
- ◇ Trailer Ball & Receiver not Included

3-Point 1200 lb. Pallet Fork

- ◇ Designed to carry 1200 lbs.
- ◇ Cat. 1 Hitch
- ◇ 26" High Frame and 46" Forks

Clamp on Bucket Forks

- ◇ 2000 lbs. carrying capacity per pair
- ◇ Fork Dimensions 4" x 2" x 44"



Ball & Receiver



Model	Description	Hitch	Weight	List Price
QH1	Cat. 1 Adapter	Cat. 1	67 lbs.	\$220
QH2	Cat. 2 Adapter Max 100HP	Cat. 2	102 lbs.	\$375
TM1	Trailer Mover (2"x2" Post)	Cat. 1	35 lbs.	\$275
TM2	Trailer Mover (3.2" x 3.2" Post)	Cat. 1	56 lbs.	\$320
PF	46" 3-Pt. Pallet Fork	Cat. 1	106 lbs.	\$385
BFT2000	44" Clamp-on Bucket Forks	N/A	108 lbs./pair	\$385 (Pair)

OPTIONAL EQUIPMENT

QHA-1KIT	Quick Hitch Bushing Set—Cat. 1 (Parts Discount)			\$27
QHA-2KIT	Quick Hitch Bushing Set—Cat. 2 (Parts Discount)			\$23
QHA-25	Quick Hitch 1 Adapter Bracket (Parts Discount)			\$22

Prices and specifications subject to change without notice. Check discounts & availability before quoting.
Product Designs May Differ Slightly Than What Appears in the Photographs.

SKIDDING

Tajfun Planina, founded in 1967, provides complete and integrated solutions in the field of forestry machinery with efficient service, after-sale support and comprehensive sales networks in more than 50 countries around the world. Our primary products include single and double drum logging winches, firewood processors and forestry accessories. We completely test each individual machine for full functionality, ensuring we meet significant international quality and safety standards.

Tajfun started developing and manufacturing logging winches in 1979. We constantly update, upgrade and develop different winch types for different needs.

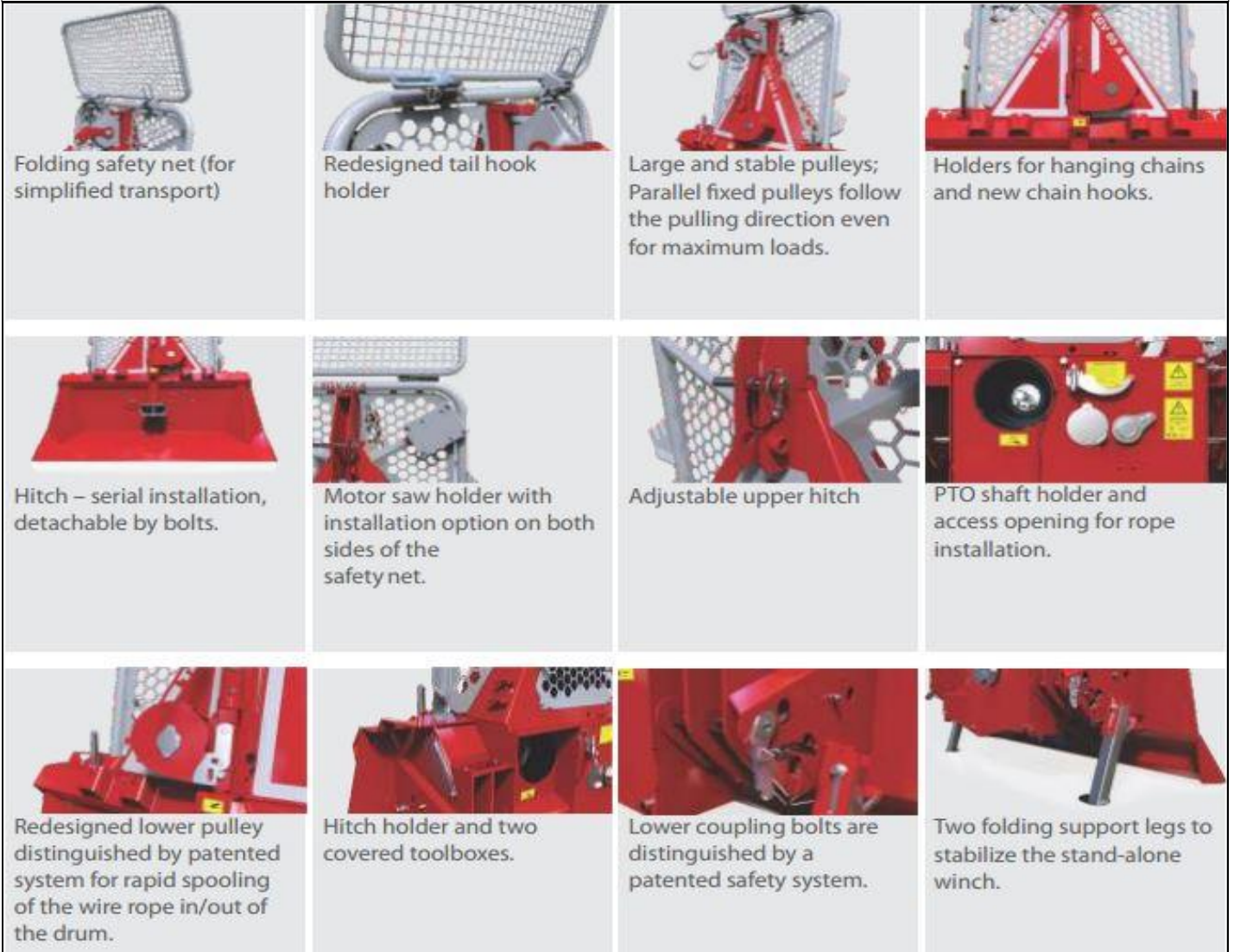

Features:

- ◇ Reliable and easy mechanical control—High efficiency and safety
- ◇ Very simple and fast installation to tractor's three point mounting system
- ◇ Robotic welded stable and robust construction
- ◇ Made of high quality steel, laser cut and powder coated
- ◇ Sturdy drive line, each shaft with double bearings and double reduction gearing (winches from 10,000-22,500 lbs)
- ◇ Highly efficient clutch activation, even with mechanical winches – short pull, low activation pressure
- ◇ Chainsaw holder, Peavey holder & Tool compartment standard (tool compartment not available on EGV-35A)

WINCHES



	Pulling Force	Brake Force	Gear Ratio	Rope Velocity (540 RPM)	Rope Velocity (300 RPM)	Tractor Range	Width	Length	Transport Height (wireguard folded)	Working Height (wireguard extended)	Weight (w/o Wire Rope)	Hitch Category	LIST PRICE
EGV-35A	3.9 Tf (35 kN)	4.9 Tf (44 kN)	01:07:5	2.0–3.9 ft/s	1.1–2.2 ft/s	30–50 HP	47.5 in.	19.3 in.	47.5 in.	78.7 in.	528 lbs.	1&2	\$3,870
EGV-45A	5.0 Tf (45 kN)	6.3 Tf (56 kN)	01:08:9	1.8–3.5 ft/s	1.0–2.0 ft/s	40–75 HP	55.0 in.	20.7 in.	55.0 in.	90.6 in.	726 lbs.	1&2	\$4,720
EGV-55A	6.1 Tf (55 kN)	7.7 Tf (69 kN)	01:08:9	1.8–3.5 ft/s	1.0–2.0 ft/s	50–80 HP	59.0 in.	22.2 in.	59.0 in.	90.6 in.	759 lbs.	1&2	\$6,070
EGV-55AHKSG	6.1 Tf (55 kN)	7.7 Tf (69 kN)	01:08:9	1.8–3.5 ft/s	1.0–2.0 ft/s	50–80 HP	59.0 in.	22.2 in.	59.0 in.	90.6 in.	803 lbs.	1&2	\$10,970
EGV-65A	7.3 Tf (65 kN)	9.1 Tf (81 kN)	01:10:8	1.6–3.2 ft/s	0.9–1.8 ft/s	55–90 HP	65.3 in.	26.3 in.	65.3 in.	90.6 in.	1133 lbs.	2&3	\$6,890
EGV-65AHKSG	7.3 Tf (65 kN)	9.1 Tf (81 kN)	01:10:8	1.6–3.2 ft/s	0.9–1.8 ft/s	55–90 HP	65.3 in.	26.3 in.	65.3 in.	90.6 in.	1188 lbs.	2&3	\$12,280
EGV-85AHKSG	9.5 Tf (85 kN)	11.9 Tf (106 kN)	01:10:7	1.7–3.6 ft/s	0.9–2.0 ft/s	65–135 HP	70.8 in.	26.8 in.	70.8 in.	90.6 in.	1298 lbs.	2&3	\$13,690

	Bottom Pulley	Trailer Hitch	Differential Brake Band	Radio Remote Control	Powered Upper Pulley
EGV-35A	✓	✓	✓	X	X
EGV-45A	✓	✓	✓	X	X
EGV-55A	✓	✓	✓	X	X
EGV-55AHKSG	✓	✓	✓	Option	✓
EGV-65A	✓	✓	✓	X	X
EGV-65AHKSG	✓	✓	✓	Option	✓
EGV-85AHKSG	✓	✓	✓	Option	✓

AHK models have a self-contained electric-over-hydraulic system which actuates the clutch and brake. These winches also require a 12V power supply from the tractor (the cable drum is still powered by the tractor PTO). Instead of ropes the AHKs are equipped with a control pendant that can easily reach the driver's seat or either side of the tractor

SG Refers to Power off Spooling

OPTIONAL EQUIPMENT

Model	Description	List Price
5167G70AJ	5/16 x 7 G70 Choker Chain	\$55.00 (Parts Discount)
870.03.023HB	Remote Control for AHK model	\$2,125
TJ241259	Fuel Canister	\$110
TJ212151	Snatch Bock	\$440



High quality, wide protection blade with an enforced lower blade, made of **Hardox metal**. Wedged shape of the blade ensures safe anchoring.

Not available for sale in the following states:

NY - NH - VT - ME - MA - CT - RI - OH



WOOD CHIPPER

Tired of all those piles of branches laying around? Need to cover your flowerbeds in a practical and attractive way? Try the Tar River Implements BWC Series Wood Chipper for your home landscaping needs.

The Tar River Wood Chipper is the perfect tool to help you clear your land of fallen limbs and branches. Use your wood chips to create beautifully covered flowerbeds and natural areas in the yard. Wood chips not only look nice, but they also help regulate soil temperature, retain moisture and even improve plant growth by helping release necessary nutrients into the soil.

We are now introducing our new series of Self-Contained Hydraulic Feed Chippers. This new series is available in 4", 6", and 8" chipping capacities. These chippers come equipped with internal hydraulic pumps that are run by the tractor PTO and require no external hydraulic feed.

BWC-080-H



Reversible
Blades!



BWC-040EC

Model	Chipping Capacity	HP	Chipper Wheel	Discharge Hood Height	Weight	List Price
MANUAL FEED						
BWC-040EC	4"	18-50	23.5" / 72 lbs.	59"	434 lbs.	\$2,525
SELF-CONTAINED HYDRAULIC FEED W/ PTO						
BWC-040-H	4"	18-50	18.5" / 55 lbs.	74"	584 lbs.	\$3,375
BWC-060-H	6"	35-100	24.8" / 128 lbs.	83"	794 lbs.	\$3,875
BWC-080-H	8"	35-100	24.7" / 131 lbs.	81"	891 lbs.	\$4,625

TAR RIVER ATTACHMENTS

NOTES AND GENERAL INFORMATION



Standard Universal Skid Steer



Euro/Global



John Deere

- ◇ Standard Mounting is **Universal Skid Steer Mount** (except when noted otherwise)
 - ◇ Euro/Global optional at additional costs—use prefix “EG”.
 - ◇ JD Mounts optional at additional costs—use prefix “JD”.
- Mounts fit these loaders:
 - ◇ 200X, 200CX, 210, 300, 300X, 300CX, 400, 400X, 400CX, 520, 521, 540, 541, 542
- ◇ Hydraulic Hoses & Flat Faced Couplers come standard when necessary with all units except when noted otherwise.



TR ATTACHMENTS

Due to product availability these past couple years, it has become impossible to maintain an inventory our customers have become accustomed to.

We are therefore, limiting our price book to those items that we continuously have on order from our suppliers.

Although not in the price book, we also have available for special order any of the following products in our ATTACHMENT line. Please note these will require an extended lead time.

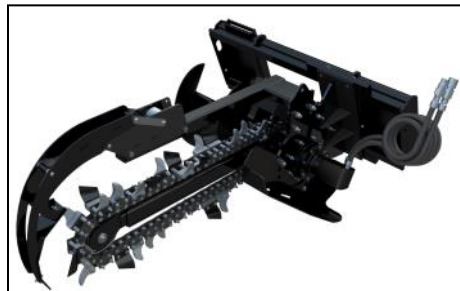

BUCKETS	BALE SPEARS
ROCK	HIGH BACK DOUBLE
LOW PROFILE	HIGH BACK TRIPLE
LONG BOTTOM	
MATERIAL	MISC
4-IN-1	STUMP GRINDERS
DISBURSEMENT	TRENCHERS
HIGH DUMP	TREE BOOM
STUMP	TREE & POST PULLER
	TREE SHEAR
GRAPPLES	BACK HOE
ROCK	MANURE FORKS
STUMP	SKID STEER TRAILER MOVER
BRUSH	SNOW BLADE
FORK	SNOW PUSHER

PALLET FORKS - BUCKETS - GRAPPLES



PALLET FORKS

Model	Description	Loader	Capacity	Fork Lengths	Weight
SCPF	Sub Compact	Sub-Compact	900 lbs.	36" or 42"	190 lbs. - 205 lbs.
CPF	Compact	Compact	2,000 lb. & 3,000 lb.	42" - 48"	235 lbs. - 274 lbs.
EPF	Economy	Compact or Utility	4,200 lb.	48"	395 lbs.
MPF	Medium Duty	Utility or Larger	4,200 lb.	42" or 48"	376 lbs. - 394 lbs.
HPF	Heavy Duty	Utility or Larger	5,200 lb.	48" or 60"	414 lbs. - 460 lbs.
WTPF & WTHPF	Walk Through	Skid Steer	4,200# & 5,200 lb.	42" - 48" - 60"	378 lbs. - 394 lbs.
HYPF	Hyd. Side Shift	Utility or Larger	4,200 lb.	48"	436 lbs.

BUCKETS

Model	Description	Typical Uses
RB	Rock Bucket	Essential attachment for separating rocks from dirt as well as for clearing and building sites. Ideal for sifting out large rocks and debris. Catches rocks 3" plus.
LP	Low Profile Bucket	High visibility specifically designed for skid steer loaders. For general purpose grading and moving dirt.
LB	Long Bottom Bucket	Built heavy for large skid steer applications. An excellent attachment for precise grading and construction purposes. 35 1/2" deep to allow for easy view of front edge while working.
CU	Compact Utility	All around general purpose specifically made for tractor loaders.
XMB	Material Bucket	Material /Snow / Litter bucket is used for moving litter, chips, snow and other light material.
4N1	4-IN-1 Bucket	Multi-purpose bucket for grappling, dozing, backfilling , loading, digging and fine grading
DB	Disbursement Bucket	Bucket attachment for carrying concrete, filling grain feeders, moving gravel and dirt. .85 Yard struck Capacity
HDB	High Dump Bucket	This bucket allows an extra 3 feet of dumping height for full loading capacity of truck or spreader.
HDGB	Grapple Bucket	Multi-purpose tool combining bucket and grapple
SB	Stump Bucket	Attachment bucket designed to dig around stumps with its narrow cutting surface for easy stump removal. Great for digging narrow ditches for footings or storm ditches.

GRAPPLES

Model	Description	Typical Uses
RG	Rock Grapple	A fundamental implement for separating rocks from dirt as well as for contractors clearing a lot for site building. It is also essential for storm damage clean up. The Rock Grapple is ideal for sifting out large rocks and debris. It is excellent in pastures, lawns or construction sites. It will catch any rock or piece of debris that is larger than 3 inches
SBG	Stump Bucket	Used for prying and removing stumps with the gripping power to secure the load
RG	Root Grapple	Moving logs, brush, rocks or many other types of debris. Available in single and double grapple configurations CRG (< 40 HP) HDRG1 (35-50 HP) HDRG2 (40-60HP) XRG (60+ HP)
BG	Brush Grapple	Deigned for tearing into roots, trash and rubbish and loading the debris into trucks or wagons. Designed to roll debris into tight piles.
HFG	Fork Grapple	An essential tool on the farm, logging and construction industry. Great for moving logs, fence posts, pipes and debris.
FG	Log Grapple	Unique rounded tine design to easily hold large logs, pipes, fence posts and culverts.

Prices and specifications subject to change without notice. Check discounts & availability before quoting.
Product Designs May Differ Slightly Than What Appears in the Photographs.



PALLET

SUB-COMPACT PALLET FORKS

- ◇ Light, Durable Frame & Forks great for Sub-Compact Tractors
- ◇ **SCPF36** = 900 lbs. Lift Capacity - 36" forks
- ◇ **SCPF42** = 900 lbs. Lift Capacity - 42" forks
- ◇ Standard Universal Skid Steer Mount
- ◇ Optional JD Mount Available



SCPF SERIES

COMPACT PALLET FORKS

- ◇ Light, Durable Frame & Forks great for Compact Tractors
- ◇ **CPF42** = 2,000 lbs. Lift Capacity - 42" forks
- ◇ **CPF48** = 3,000 lbs. Lift Capacity - 48" forks
- ◇ Standard Universal Skid Steer Mount
- ◇ Optional JD Mount Available



CPF SERIES

MEDIUM & HEAVY DUTY PALLET FORKS

- EPF SERIES** —
- ◇ 4,200 Lift Capacity
 - ◇ 48" Forks
 - ◇ Standard Universal Skid Steer Mount
 - ◇ Optional JD Mount Available



EPF SERIES

- MPF & HPF SERIES** —
- ◇ Use The Same Heavy Built Frames
 - ◇ Frames Are Rated For Up To 5,500 lbs.
 - ◇ The Only Difference Between The MPF & HPF Series are the Fork Ratings
 - ◇ The Same Applies For the Walk-Thru Forks

- MPF SERIES** —
- ◇ 4,200 lbs. Lift Capacity
 - ◇ 42" & 48" Forks Available
 - ◇ Walk-Thru Frames Available as **WTPF Series**
 - ◇ Standard Universal Skid Steer Mount
 - ◇ Optional JD & Euro/Global Mounts Available



MPF SERIES

- HPF SERIES** —
- ◇ 5,200 lbs. Lift Capacity
 - ◇ 48" & 60" Forks Available
 - ◇ Walk-Thru Frames Available as **WTHPF Series**
 - ◇ Standard Universal Skid Steer Mount
 - ◇ Optional JD & Euro/Global Mounts Available

FORKS



Model	Description	Capacity	Mount	Weight	List Price	Packed
SUB COMPACT FORKS - 900 LBS.						
SCPF36	Sub Compact Pallet Forks - 36" Forks	900 lbs.	Uni. Skid Steer	161 lbs.	\$575	10
JDSCPF36	Sub Compact Pallet Forks - 36" Forks	900 lbs.	JD 200/300	150 lbs.	\$575	10
SCPF42	Sub Compact Pallet Forks - 42" Forks	900 lbs.	Uni. Skid Steer	171 lbs.	\$595	10
JDSCPF42	Sub Compact Pallet Forks - 42" Forks	900 lbs.	JD 200/300	160 lbs.	\$595	10
COMPACT FORKS - 2,000 LBS. & 3,000 LBS.						
CPF42	Compact Pallet Forks - 42" Forks	2,000 lbs.	Uni. Skid Steer	253 lbs.	\$735	5
JDCPF42	Compact Pallet Forks - 42" Forks	2,000 lbs.	JD 200/300 and 400/500	253 lbs.	\$735	5
CPF48	Compact Pallet Forks - 48" Forks	3,000 lbs.	Uni. Skid Steer	274 lbs.	\$890	5
JDCPF48	Compact Pallet Forks - 48" Forks	3,000 lbs.	JD 200/300 and 400/500	274 lbs.	\$890	5
MEDIUM DUTY FORKS - 4,200 LBS.						
MPF42	Medium Duty Forks - 42" Forks	4,200 lbs.	Uni. Skid Steer	376 lbs.	\$1,150	5
EGMPF42	Medium Duty Forks - 42" Forks	4,200 lbs.	Euro/Global	376 lbs.	\$1,150	5
JDMPF42	Medium Duty Forks - 42" Forks	4,200 lbs.	JD 200/300 and 400/500	376 lbs.	\$1,150	5
MPF48	Medium Duty Forks - 48" Forks	4,200 lbs.	Uni. Skid Steer	394 lbs.	\$1,175	5
EGMPF48	Medium Duty Forks - 48" Forks	4,200 lbs.	Euro/Global	394 lbs.	\$1,175	5
JDMPF48	Medium Duty Forks - 48" Forks	4,200 lbs.	JD 200/300 and 400/500	394 lbs.	\$1,175	5
EPF48	Med. Duty Cage Design- 48" Forks	4,200 lbs.	Uni. Skid Steer	395 lbs.	\$995	5
JDEPF48	Med. Duty Cage Design- 48" Forks	4,200 lbs.	JD 200/300 and 400/500	395 lbs.	\$995	5
HEAVY DUTY FORKS - 5,200 LBS.						
HPF48	Heavy Duty Forks - 48" Forks	5,200 lbs.	Uni. Skid Steer	414 lbs.	\$1,210	5
EGHPF48	Heavy Duty Forks - 48" Forks	5,200 lbs.	Euro/Global	414 lbs.	\$1,210	5
JDHPF48	Heavy Duty Forks - 48" Forks	5,200 lbs.	JD 200/300 and 400/500	414 lbs.	\$1,210	5
HPF60	Heavy Duty Forks - 60" Forks	5,200 lbs.	Uni. Skid Steer	460 lbs.	\$1,285	5
EGHPF60	Heavy Duty Forks - 60" Forks	5,200 lbs.	Euro/Global	460 lbs.	\$1,285	5
JDHPF60	Heavy Duty Forks - 60" Forks	5,200 lbs.	JD 200/300 and 400/500	460 lbs.	\$1,285	5

Prices and specifications subject to change without notice. Check discounts & availability before quoting.
 Product Designs May Differ Slightly Than What Appears in the Photographs.

PALLET FORKS



HYDRAULIC PALLET FORKS

- ◇ Same Frame as our MPF48 but with welded-on 48" forks that can be moved hydraulically from side to side
- ◇ Available in 48" forks, 4,200 lbs. forks only
- ◇ Units Come Standard With Flat Faced Couplers & Hoses
- ◇ Standard Universal Skid Steer Mount
- ◇ Optional JD or Euro/Global Mounts

HYPF SERIES



WALK THRU PALLET FORKS

- WTPF Series** —
- ◇ 4,200 lbs. Lift Capacity
 - ◇ 42" & 48" Forks Available
 - ◇ Standard Universal Skid Steer Mount
- WTHPF Series** —
- ◇ 5,200 lbs. Lift Capacity
 - ◇ 48" & 60" Forks Available
 - ◇ Standard Universal Skid Steer Mount

WTPF SERIES



Model	Description	Capacity	Mount	Weight	List Price	Packed
WALK-THRU MEDIUM DUTY FORKS - 4,200 LBS.						
WTPF42	Walk-Thru Med. Duty Forks - 42"	4,200 lbs.	Uni. Skid Steer	378 lbs.	\$1,150	5
WTPF48	Walk-Thru Med. Duty Forks - 48"	4,200 lbs.	Uni. Skid Steer	396 lbs.	\$1,175	5
WALK-THRU HEAVY DUTY FORKS - 5,200 LBS.						
WTHPF48	Walk-Thru Heavy Duty Forks - 48"	5,200 lbs.	Uni. Skid Steer	416 lbs.	\$1,210	5
WTHPF60	Walk-Thru Heavy Duty Forks - 60"	5,200 lbs.	Uni. Skid Steer	462 lbs.	\$1,285	5
HYDRAULIC PALLET FORKS						
HYPF48	Hydraulic Shift Pallet Forks - 48"	4,200 lbs.	Uni. Skid Steer	436 lbs.	\$2,425	1

INDIVIDUAL TINES	Model	Size (in.)	List Price Per Tine
	COM-111802 – SCPF, JDSCPF	1 x 3 x 36	2A \$110
	COM-111803 – SCPF, JDSCPF	1 x 3 x 42	2A \$120
	COM-90222 – CPF, JDCPF	1.18 x 3 x 42	2A \$135
	COM-80489 – CPF/JD, EFP/JD, MPF/JD/EG, WTPF	1.38 x 4 x 48	2A \$215
	COM-83801 – HPF/JD/EG, WTHPF	1.5 x 4 x 48	2A \$235
	COM-87132 – HPF/JD/EG, WTHPF	1.5 x 4 x 60	2A \$305
	COM-401830 – OPTIONAL	1.5 x 4 x 72	2A \$375

BALE SPEARS



LOADER MOUNT BALE SPEARS

- EBS Series** —
 - ◇ Standard Universal Skid Steer Mount Only
 - ◇ Single Spear Configuration Only
 - ◇ 49" Spear
 - ◇ 2,800 lbs. capacity
- BS Series** —
 - ◇ Standard Universal Skid Steer Mount
 - ◇ Optional JD & Euro/Global Mounts Available
 - ◇ Hi-Back Configurations Available (HBS Series)
 - ◇ Single, Double & Triple Spear Configurations Available
 - ◇ Standard 49" Spear
 - ◇ 3,500 lbs. capacity



Model	Description	Capacity	Mount	Weight	List Price	Packed
LOADER MOUNT - SINGLE SPEAR						
EBS1	Quick-Attach Bale Spear - 49"	2,800 lbs.	Uni. Skid Steer	157 lbs.	\$645	8
BS1-HD	Lo-Back Bale Spear - <i>Single</i> 49"	3,500 lbs.	Uni. Skid Steer	189 lbs.	\$765	5
EGBS1-HD	Lo-Back Bale Spear - <i>Single</i> 49"	3,500 lbs.	Euro/Global	189 lbs.	\$880	5
JDBS1-HD	Lo-Back Bale Spear - <i>Single</i> 49"	3,500 lbs.	JD	189 lbs.	\$880	5
LOADER MOUNT - DOUBLE SPEAR						
BS2-HD	Lo-Back Bale Spear - <i>Double</i> 49"	3,500 lbs.	Uni. Skid Steer	233 lbs.	\$895	5
EGBS2-HD	Lo-Back Bale Spear - <i>Double</i> 49"	3,500 lbs.	Euro/Global	233 lbs.	\$1,010	5
JDBS2-HD	Lo-Back Bale Spear - <i>Double</i> 49"	3,500 lbs.	JD	233 lbs.	\$1,010	5
LOADER MOUNT - TRIPLE SPEAR						
BS3-HD	Lo-Back Bale Spear - <i>Triple</i> 39"	3,500 lbs.	Uni. Skid Steer	291 lbs.	\$925	5
EGBS3-HD	Lo-Back Bale Spear - <i>Triple</i> 39"	3,500 lbs.	Euro/Global	291 lbs.	\$1,040	5
JDBS3-HD	Lo-Back Bale Spear - <i>Triple</i> 39"	3,500 lbs.	JD	291 lbs.	\$1,040	5

Prices and specifications subject to change without notice. Check discounts & availability before quoting.
 Product Designs May Differ Slightly Than What Appears in the Photographs.

BALE GRABBERS & UNWINDERS



BALE GRABBERS

RBG Series - For Round Bales (opens 48" - 78")

- ◇ Available with 1 or 2 Hyd. Cylinders
- ◇ Available in Universal Skid Steer or Euro/Global Mounts
- ◇ Circular Design Ensures Strong & Gentle Grip of Bale
- ◇ Loader Mount Legs Provide Easy Hook-Up/Disconnect
- ◇ Units Come Standard With Hydraulic Hoses -No Couplers



RBG SERIES

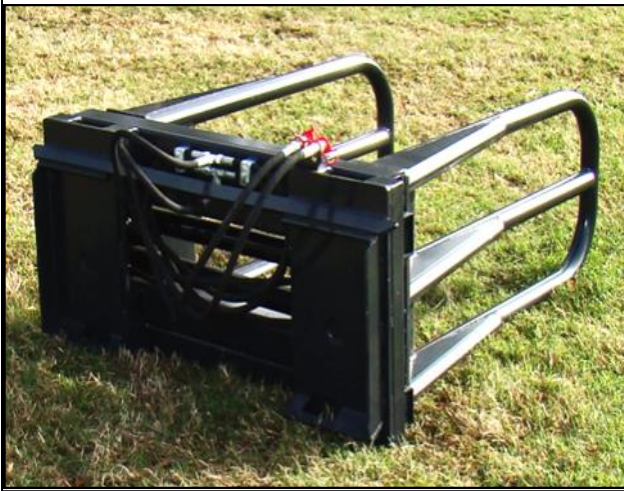

SBG Series - For Square/Round Bales (opens 26"-80")

- ◇ Comes Standard with 2 Hyd. Cylinders
- ◇ Available in Universal Skid Steer or Euro/Global Mounts
- ◇ Loader Mount Legs Provide Easy Hook-Up/Disconnect
- ◇ Units Come Standard With Hydraulic Hoses - No Couplers

SBG SERIES

Model	Description	Capacity	Mount	Weight	List Price	Packed
ROUND BALE GRABBER						
RBG-101	Round Bale Grabber - 1 Cydr.	2,200 lbs.	Uni. Skid Steer	430 lbs.	\$2,475	3
RBG-102	Round Bale Grabber - 1 Cydr.	2,200 lbs.	Euro/Global	430 lbs.	\$2,475	3
RBG-201	Round Bale Grabber - 2 Cydr.	2,200 lbs.	Uni. Skid Steer	446 lbs.	\$2,875	3
RBG-202	Round Bale Grabber - 2 Cydr.	2,200 lbs.	Euro/Global	446 lbs.	\$2,875	3
SQUARE BALE GRABBER						
SBG-201	Square Bale Grabber - 2 Cydr.	2,200 lbs.	Uni. Skid Steer	661 lbs.	\$2,475	1
SBG-202	Square Bale Grabber - 2 Cydr.	2,200 lbs.	Euro/Global	661 lbs.	\$2,475	1



RBU SERIES

- ◇ Hydraulic Bale Unwinder
- ◇ 3 Bale Spears
- ◇ 3 point and Universal Skid Steer mount

Model	Description	Mount	Weight	List Price
ROUND BALE UNWINDER				
RBU-100	Round Bale Unwinder	Round Bale Unwinder	353 lbs.	\$3,320

RBU SERIES

BUCKETS



COMPACT UTILITY BUCKET

- ◇ Great For Compact Tractors
- ◇ 19" High x 18" Deep
- ◇ 4" x 1/2" Cutting Edge
- ◇ Heavy, Durable Construction
- ◇ For units below 45 HP
- ◇ Standard Universal Skid Steer Mount
- ◇ Optional JD Mount
- ◇ Available Sizes: 48", 60" & 72"



CUB SERIES

Model	Description	Struck Capacity	Mount	Weight	List Price
COMPACT UTILITY BUCKET					
CUB48	Compact Utility Buckets - 48"	.22 ³	Universal Skid Steer	157 lbs.	\$895
CUB60	Compact Utility Buckets - 60"	.27 ³	Universal Skid Steer	201 lbs.	\$995
CUB72	Compact Utility Buckets - 72"	.32 ³	Universal Skid Steer	245 lbs.	\$1,115

BEAST SERIES LB BUCKET

- ◇ Heavy Duty Long Bottom, Low Profile Bucket
- ◇ 4" x 4" Rectangular Tubing Frame
- ◇ A-36 Steel with 3/4" x 6" cutting edge
- ◇ 1/4" Wrap & 1/2" Wall
- ◇ 1/2" Wear Bars and Side Cutters
- ◇ 21 3/4" High x 37.9" Deep
- ◇ Weld-On & Bolt-On Teeth Available
- ◇ Heavy, Durable Construction
- ◇ Standard Universal Skid Steer Mount
- ◇ Available Sizes: 78" & 84"



BB SERIES

Model	Description	Struck Capacity	Mount	Weight	List Price
BEAST SERIES					
BB78	Beast Series—78"	1.23 ³	Universal Skid Steer	815 lbs.	\$2,675
BB78T	Beast Series—78" with Teeth	1.23 ³	Universal Skid Steer	855 lbs.	\$2,880
BB84	Beast Series—84"	1.23 ³	Universal Skid Steer	875 lbs.	\$2,975
BB84T	Beast Series—84" with Teeth	1.23 ³	Universal Skid Steer	920 lbs.	\$3,215
OPTIONAL					
EG	Euro-Global Mount instead of Skid Steer Mount (factory welded)				\$115
JD	JD Mount instead of Skid Steer Mount (factory welded)				\$115
BOSS2	Optional Side Cutters—BEAST BUCKET (Set of 2)				\$165

Prices and specifications subject to change without notice. Check discounts & availability before quoting.
Product Designs May Differ Slightly Than What Appears in the Photographs.

UTILITY ROOT GRAPPLES



Specially designed for tractors and utility work. Heavy built, but still light weight to not overpower your tractor lift capabilities. All Compact Root Grapples come standard with hoses and Pioneer Couplers. All Standard Duty Root Grapples come standard with hoses and Flat-Faced Couplers. Available in JD and Euro Mounts.

	COMPACT	STANDARD DUTY
HP Rating	Under 40	Under 50
Frame	3" x 3"	3" x 3"
Tines	3/8"	3/8"
Spacing	10"	9 1/4"
Max Opening	34"	35"
Depth	29"	35 1/2"
Height Closed	16"	15 1/2"
Cylinders	2" x 8"	2" x 10"
Widths	48" - 60" - 72"	60" - 66" - 72"



**CRG
SERIES**



**SDRG200
SERIES**

Model	Description	Mount	Weight	List Price	Packed (same size)
SUB COMPACT ROOT GRAPPLE - TRACTOR LOADER USE ONLY					
SCRG48	Sub Compact Root Grapple - Single Grapple - 48"	Uni. Skid Steer	250 lbs.	\$1,760	2
COMPACT ROOT GRAPPLE - TRACTOR LOADER USE ONLY					
CRG48	Compact Root Grapple - Single Grapple - 48"	Uni. Skid Steer	420 lbs.	\$1,725	2
CRG60	Compact Root Grapple - Double Grapple - 60"	Uni. Skid Steer	438 lbs.	\$1,975	2
CRG66	Compact Root Grapple - Double Grapple - 66"	Uni. Skid Steer	465 lbs.	\$2,065	2
CRG72	Compact Root Grapple - Double Grapple - 72"	Uni. Skid Steer	487 lbs.	\$2,175	2
STANDARD DUTY ROOT GRAPPLE - TRACTOR LOADER USE ONLY					
SDRG260	Standard Duty Root Grapple—Double Grapple—60"	Uni. Skid Steer	600 lbs.	\$3,125	2
SDRG266	Standard Duty Root Grapple—Double Grapple—66"	Uni. Skid Steer	625 lbs.	\$3,225	2
SDRG272	Standard Duty Root Grapple—Double Grapple—72"	Uni. Skid Steer	650 lbs.	\$3,325	2
PREFIX	OPTIONAL				
JD	JD Mount instead of Skid Steer Mount (factory welded)				\$115
EG	Euro-Global Mount instead of Skid Steer Mount (factory welded)				\$115

COMMERCIAL ROOT GRAPPLES



Heavy designed for higher HP tractors and skid steer for intense commercial applications. Commercial Root Grapples come standard with hoses and Flat Faced Couplers. Available in JD and Euro Mounts.

	HEAVY DUTY	SERIOUS DUTY
HP Rating	Under 65	65+
Frame	4" x 4"	4" x 4"
Tines	1/2"	1/2" Inside - 5/8" Outside
Spacing	9 1/2"	9"
Max Opening	34"	37"
Depth	34 1/2"	37 1/2"
Height Closed	17"	16 1/2"
Cylinders	2" x 10"	2" x 10"
Widths	72" - 80"	72" - 80"



Model	Description	Mount	Weight	List Price
HEAVY DUTY ROOT GRAPPLE - TRACTOR LOADER OR SKID STEER USE				
HDRG272	Heavy Duty Root Grapple - Double Grapple - 72"	Universal Skid Steer	749 lbs.	\$3,650
HDRG280	Heavy Duty Root Grapple - Double Grapple - 80"	Universal Skid Steer	769 lbs.	\$3,850
SERIOUS DUTY ROOT GRAPPLE - TRACTOR LOADER OR SKID STEER USE				
XRG72	Serious Duty Root Grapple - Double Grapple - 72"	Universal Skid Steer	930 lbs.	\$4,350
XRG80	Serious Duty Root Grapple - Double Grapple - 80"	Universal Skid Steer	960 lbs.	\$4,475
XRG84	Serious Duty Root Grapple - Double Grapple - 84"	Universal Skid Steer	1,010 lbs.	\$4,725
PREFIX	OPTIONAL			
EG	Euro-Global Mount instead of Skid Steer Mount (factory welded)			\$115
JD	JD Mount instead of Skid Steer Mount (factory welded)			\$115

Prices and specifications subject to change without notice. Check discounts & availability before quoting.
Product Designs May Differ Slightly Than What Appears in the Photographs.

CLAW GRAPPLES



CLAW GRAPPLE - AR400

- ◇ Made With 3/8" AR400 Steel
- ◇ Cylinder has 2" bore & 10" stroke
- ◇ Units Come Standard With Pioneer Couplers & Hoses
- ◇ Universal Skid Steer Mount & JD Mount
- ◇ Dual Cylinders
- ◇ 55" & 66" Working Widths
- ◇ **BUILT FOR SUB-COMPACT TRACTORS ONLY**



STD DUTY CLAW GRAPPLE

- ◇ Cylinder has 2 1/2" bore & 8" stroke
- ◇ Units Come Standard With Pioneer Couplers & Hoses
- ◇ Universal Skid Steer Mount
- ◇ Dual Cylinders
- ◇ 60", 66" & 72" Working Widths

Model	Description	Width	Mount	Weight	List Price	Packed (same size)
COMPACT CLAW GRAPPLE - AR 400 STEEL - UNDER 25 HP - TRACTOR LOADER USE ONLY						
CCG55-AR	Compact Claw Grapple 55" with AR400 Steel	55"	Uni. Skid Steer	205 lbs.	\$1,925	2
JDCCG55-AR	Compact Claw Grapple 55" with AR400 Steel	55"	John Deere Mount	192 lbs.	\$1,925	2
CCG66-AR	Compact Claw Grapple 66" with AR400 Steel	66"	Uni. Skid Steer	220 lbs.	\$2,075	2
JDCCG66-AR	Compact Claw Grapple 66" with AR400 Steel	66"	John Deere Mount	210 lbs.	\$2,075	2
STANDARD DUTY CLAW GRAPPLE UP TO 50 HP - TRACTOR LOADER USE ONLY						
SDCG60	Standard Duty Claw Grapple 60"	60"	Uni. Skid Steer	367 lbs.	\$2,025	2
SDCG66	Standard Duty Claw Grapple 66"	66"	Uni. Skid Steer	387 lbs.	\$2,125	2
SDCG72	Standard Duty Claw Grapple 72"	72"	Uni. Skid Steer	407 lbs.	\$2,225	2

VIBRATING POST DRIVER



Tar River Manufacturing Post Drivers are designed to efficiently drive posts and break concrete on your skid steer or excavator by quickly attaching the adaptor that fits your machine with the assistance of only 2 pins.

The new Economy Drive uses an imported drive while the HD Drive uses a fully USA-built machine. All HD models are designed to use with the auger system and come standard with spring suspended Hydraulic hoses.

BPD-750SW offers the same features as the BPD-750, but comes with a swivel system for unlevel terrain.



Model	Description	Ft. lbs. Energy	GPM	Post Pad Size	Mount	Weight	List Price
ECONOMY POST DRIVER							
PD-68-200	Post Driver	750 lbs.	10.5-19	8"	Uni. Skid Steer	1,200 lbs.	\$5,315
PD-75-240	Post Driver	1,000 lbs.	13-24	8"	Uni. Skid Steer	1,650 lbs.	\$6,255
HD POST DRIVER							
BPD-680	Post Driver	750 lbs.	10.5-19	8"	Uni. Skid Steer	1,200 lbs.	\$8,195
BPD-750	Post Driver	1,000 lbs.	13-24	9"	Uni. Skid Steer	1,650 lbs.	\$10,350
BPD-750SW	PD w/ Swivel	1,000 lbs.	13-24	9"	Uni. Skid Steer	1,800 lbs.	\$12,230
PREFIX	OPTION - MUST BE ORDERED WITH POST DRIVER						
BPD-A10	Auger System Motor						\$4,130

Prices and specifications subject to change without notice. Check discounts & availability before quoting.
 Product Designs May Differ Slightly Than What Appears in the Photographs.

HEAVY DUTY BRUSH CUTTER



TRBC60

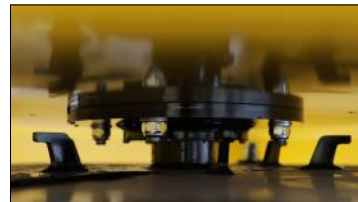

Low profile blade assembly with Anti-wrapping rotor protection gives superior strength than with traditional designs

HEAVY DUTY BRUSH CUTTER

- ◇ Low-Flow Cutter (14/23)
 - ◇ Open-Faced, Heavy Duty Deck made with 1/4" A36 Steel
 - ◇ 5" Cutting Capacity
 - ◇ Hydraulic Direct Drives & Internal Relief Valve
 - ◇ Bi-Directional Cutting
 - ◇ 3 Cutting Blades (60SiMn steel)
 - ◇ Units Come Standard With Flat Faced Couplers & Hoses
 - ◇ Standard Universal Skid Steer Mount
- RECOMMENDED: FLOW 14-20 GPM DO NOT EXCEED 23 GPM**

Model	Description	Cutting Capacity	Flow	Mount	Weight	List Price
HEAVY DUTY						
TRBC60	5 Foot Heavy Duty Brush Cutter	4"	14-20 gpm	Uni. Skid Steer	1074 lbs.	\$7,440
TRBC70	6 Foot Heavy Duty Brush Cutter	5"	14-20 gpm	Uni. Skid Steer	1530 lbs.	\$8,475

SERIOUS DUTY BRUSH CUTTER



SERIOUS DUTY BRUSH CUTTER

- ◇ Low-Flow Cutter (16/25)
- ◇ Open Faced, Heavy Duty Deck made with 1/4" A36 Steel
- ◇ 6" Cutting Capacity
- ◇ Hydraulic Direct Drives & Internal Relief Valve
- ◇ Bi-Directional Cutting
- ◇ Extreme Blade Pan That is Extra Large To Maintain Force & Momentum
- ◇ 2 Cutting Blades (AR-500)
- ◇ Units Come Standard With Flat Faced Couplers & Hoses

- ◇ Standard Universal Skid Steer Mount
- ◇ Optional JD or Euro/Global Mounts
- ◇ Available Sizes: 60" & 72"

RECOMMENDED: FLOW 16-25 GPM DO NOT EXCEED 28 GPM
CALL FOR HIGH FLOW OPTIONS

Model	Description	Mount	Weight	List Price
SERIOUS DUTY				
XBC60	Serious Duty Brush Cutter - Low-Flow - 60"	Uni. Skid Steer	1,300 lbs.	\$8,150
XBC72	Serious Duty Brush Cutter - Low-Flow - 72"	Uni. Skid Steer	1,802 lbs.	\$8,950
PREFIX	OPTIONAL			
EG	Euro-Global Mount instead of Skid Steer Mount (factory welded)			\$115
JD	JD Mount instead of Skid Steer Mount (factory welded)			\$115

SNOW REMOVAL



COMPACT SNOW BLADE

- ◇ Standard Universal Skid Steer Mount
- ◇ Reversible & Replaceable Rubber Edge
- ◇ Hydraulic Angle Left or Right
- ◇ Spring Loaded & Automatic Trip
- ◇ Available Sizes: 60", 72", 84" & 96"

ORDER BLADE AND DESIRED BLADE KIT.



Model	Description	Mount	Weight lbs.	List Price	Packed
SNOW BLADE WITHOUT EDGE					
CSP60NE	Compact Snow Blade 60"	Uni. Skid Steer Hitch	517	\$1,755	1
CSP72NE	Compact Snow Blade 72"	Uni. Skid Steer Hitch	537	\$1,865	1
CSP84NE	Compact Snow Blade 84"	Uni. Skid Steer Hitch	556	\$1,970	1
CSP96NE	Compact Snow Blade 96"	Uni. Skid Steer Hitch	587	\$2,185	1
JDCSP60NE	Compact Snow Blade 60"	JD Hitch	517	\$1,755	1
JDCSP72NE	Compact Snow Blade 72"	JD Hitch	537	\$1,865	1
JDCSP84NE	Compact Snow Blade 84"	JD Hitch	556	\$1,970	1
JDCSP96NE	Compact Snow Blade 96"	JD Hitch	587	\$2,185	1
RUBBER EDGE					
CSP60RE	60" Rubber Edge kit			\$175	
CSP72RE	72" Rubber Edge kit			\$200	
CSP84RE	84" Rubber Edge kit			\$225	
CSP96RE	96" Rubber Edge kit			\$250	
STEEL EDGE					
CSP60SE	60" Steel Edge kit			\$125	
CSP72SE	72" Steel Edge kit			\$140	
CSP84SE	84" Steel Edge kit			\$155	
CSP96SE	96" Steel Edge kit			\$170	
PREFIX	OPTIONAL EQUIPMENT				
CSP-HYD	Hydraulic angling Kit for CPS Model			\$515	

MISCELLANEOUS



BOLT-ON TOOTH BARS

- ◇ Convert a Smooth Edge Bucket into a Tooth Bucket
- ◇ Achieve Better Digging Power
- ◇ 1/2" x 4" Cutting Edge
- ◇ Large Pin-On Teeth (Side Pin)
- ◇ 2 Pieces of 3" Square 3/8" Thick, Pre-Drilled Steel Comes with Every Tooth Bar
- ◇ Various Size Available Upon Request - Priced Per Foot, Round Up to Nearest Foot



BOTB SERIES



QA SERIES

QUICK ATTACH PLATES

- ◇ Weld-On Universal Skid Steer Plates
- ◇ Available in 3 Thicknesses:
- ◇ Standard Duty - 1/4"
- ◇ Heavy Duty - 3/8"
- ◇ Serious Duty - 1/2"

ADAPTER BRACKETS

- ◇ **EG2SS** – Adapts Euro/Global loader mounts to universal Skid Steer mount
- ◇ **JD2SS** – Adapts JD loader mounts to universal Skid Steer mount
- ◇ **BA2SS** – Blank Adaptor to universal Skid Steer



Model	Description	List Price
TOOTH BARS (OTHER SIZES AVAILABLE UPON REQUEST)		
BOTB60	Bolt-On Tooth Bar - 60"	\$560
BOTB72	Bolt-On Tooth Bar - 72"	\$620
BOTB84	Bolt-On Tooth Bar - 84"	\$760
QUICK ATTACH PLATES		
SSQA14	Standard Duty Quick-Attach Plate - 1/4"	\$270
SSQA38	Heavy Duty Quick-Attach Plate - 3/8"	\$340
SSQA12	Serious Duty Quick-Attach Plate - 1/2"	\$420
ADAPTER BRACKETS		
EG2SS	Euro/Global to Universal Skid Steer	\$575
JD2SS	John Deere to Universal Skid Steer	\$575
BA2SS	Blank Plate to Universal Skid Steer	\$575

Prices and specifications subject to change without notice. Check discounts & availability before quoting.
Product Designs May Differ Slightly Than What Appears in the Photographs.

LIFT-SAFE IMPLEMENT HANDLER

Put down the chains and make moving and loading equipment a SAFE one-man job.



Belco Resources Equipment's Implement Handler was developed to make moving three point implements simple and worry free. The days of using chains and two people just to move a single rotary cutter, rear blade, landscape rake, etc. are over!



Run Forks In



Lift to Hook



Lower to Load

Specifications:

- ◇ Fits most three point implements
- ◇ Lift Capacity 2,000 lbs.
- ◇ Weight 241 lbs.

Model	Lift Capacity	Hitch	Weight	List Price
GSC-002	2,000	Cat 0, 1, 2 & 3	241	\$795

RATCHET STRAPS

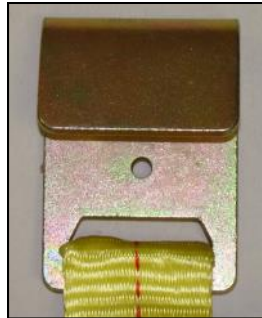

Flat Hook

Part #: 80006A-2



Wire "J" Hook

Part #: 80006A

Specifications:

- ◇ 2" x 27'
- ◇ 10,000 lbs. capacity
- ◇ Available in Flat or Wire "J" Hooks
- ◇ Sold in boxes of 10* (no mixing)



NOTES

LIMITED WARRANTY

Belco Resources Equipment warrants to the original purchaser of any new piece of machinery from Belco Resources Equipment, purchased from an authorized Belco Resources Equipment dealer, that the equipment be free from defects in material and workmanship for a period of one (1) year for non-commercial, state, and municipalities' use, ninety (90) days for commercial use from date of retail sale. The warranty for rental purposes is thirty (30) days. The obligation of Belco Resources Equipment to the purchaser under this warranty is limited to the repair or replacement of defective parts.

Replacement or repair parts installed in the equipment covered by this limited warranty are warranted for ninety (90) days from the date of purchase of such part or to the expiration of the applicable new equipment warranty period, whichever occurs later. Warranted parts shall be provided at no cost to the user at an authorized Belco Resources Equipment dealer during regular working hours. Belco Resources Equipment reserves the right to inspect any equipment or parts which are claimed to have been defective in material or workmanship.

This limited warranty does not apply to and excludes wear items such as shear pins, tires, tubes knives, blades, or other wear items. Oil or grease is not covered by this warranty.

All obligations of Belco Resources Equipment under this limited warranty shall be terminated if:

- Proper service is not performed on the machine.
- The machine is modified or altered in any way.
- The machine is being used or has been used for purposes other than those for which the machine was intended.

DISCLAIMER OF IMPLIED WARRANTIES & CONSEQUENTIAL DAMAGES

Belco Resources Equipment obligation under this limited warranty, to the extent allowed by law, is in lieu of all warranties, implied or expressed, including implied warranties of merchantability and fitness for a particular purpose and any liability for incidental and consequential damages with respect to the sale or use of the items warranted. Such incidental and consequential damages shall include but not be limited to: transportation charges other than normal freight charges; cost of installation other than cost approved by Belco Resources Equipment; duty; taxes; charges for normal service or adjustment; loss of crops or any other loss of income; rental of substitute equipment, expenses due to loss, damage, detention or delay in the delivery.

REGISTRATION

The online Warranty Registration must be completed in order to qualify for coverage on this Limited Warranty. Visit www.BR-Equipment.com, click on "Warranty Registration" and completely fill out the form to register the new piece of equipment.

EXTENDED WARRANTY

A two (2) or four (4) extended Gearbox Limited Warranty is provided for certain models at the end of the standard one (1) year warranty period. Extended Warranty does not cover labor or freight.

ITEMS NOT COVERED

1. Owner Responsibility Parts: Some items must be serviced

and/or replaced because of normal machine usage. These are defined as "**OWNER RESPONSIBILITY**" items.

- "**V** Belts – "V" belt service life varies due to application and conditions, such as:

Sandy abrasive conditions, slippage, burning due to overloading, improper adjustment, and engagement, etc. Thus, the service of a "V" belt may be measured in days to years. "V" belt replacement is normally an owner's responsibility.

- **Ground engaging and Cutter Parts** – (including tines, mower blades, wear plates, guide wheels, etc.) These parts are subject to wear, abuse, and replacement. Service life of these parts can vary from hours to years. The replacement of this category of parts is the owner's expense.
- **Tires** – Tires are matched to the normal operation of the machine. Excessive road use, abrasive field conditions, obstacles, improper inflation, etc. will drastically effect service life. Therefore, repair or replacement of tires is the owner's expense.
- **PTO's** – PTO shafts are exposed to numerous conditions that the manufacturer has no control over. **From the startup of a new machine, it is critical that they be "sized" to the specific tractor that the machine is being attached to. This must be the responsibility of the owner, with the aid and advice of the dealer.** Many dealers take this responsibility as part of the sales process; however, the owner must be aware of this issue in switching implements between tractors. Proper angle of operation is as critical as "sizing". Improper alignment will quickly damage a PTO shaft. Running a PTO during a sharp turn can cause serious damage. Machine to tractor PTO shafts are an owner's responsibility and are not a warranty item.

2. Failure due to abusive usage, lack of maintenance or accident: All repairs are the owner's expense for failures resulting from abusive usage, lack of maintenance, and/or accident.
3. Failures due to unauthorized alteration of machine or installation of unauthorized attachments: The installation of unauthorized attachments or the unauthorized alteration of a machine may overload certain components and result in unexpected repairs or overhaul. Any failure from the above is at the owner's expense.
4. Tractor Loader Attachments designated in PriceBook as "Tractor Loader Only" WILL NOT qualify for warranty if used on a SKID STEER.

BELC RESOURCES EQUIPMENT



Increasing Agricultural Productivity Since 1974!

401 Jeffreys Road
Rocky Mount, NC 27804
www.BR-Equipment.com

Tel: 252-822-7140
Fax: 252-787-5855
SALES@BR-EQUIPMENT.COM