

# U.S. Wholegoods Price List

January 4, 2024  
All prices in USD



\*HX<sup>2</sup> 13-94 shown



# Table of Contents

---

<b>16</b>	HX <sup>2</sup> Series
<b>26</b>	WRX Series
<b>34</b>	STX <sup>2</sup> Series
<b>40</b>	UTX Series
<b>42</b>	WR & W Series
<b>47</b>	Auger Tools
<b>51</b>	Utility Augers
<b>52</b>	Transfer Augers
<b>52</b>	Optional Equipment

# FARM READY

## READY TO WORK WHEN YOU ARE!

From our manufacturing floor to your farm, AGI Westfield augers with the Farm Ready package are ready to work the moment they leave our facility. Our Farm Ready package can be added to any bundle so your auger is ready to work.



### HX<sup>2</sup>10

Part #	List Price	Farm Ready	Package Net Price
01-HX21063SRCBH	\$ 34,062.00	+ 1063FR	\$ 450.00
01-HX21073SRCBH	\$ 35,505.00	+ 1073FR	\$ 500.00
01-HX21083SRCBH	\$ 38,574.00	+ 1083FR	\$ 650.00

### FREIGHT & HANDLING

Horace, ND

Boone, IA

Decatur, IL

Grand Island, NE



Only available through the stock points listed above  
Does not include any fuel surcharges that may apply

### HX<sup>2</sup>13

Part #	List Price	Farm Ready	Package Net Price
01-HX21374SRCBH	\$ 48,220.00	+ 1374FR	\$ 550.00
01-HX21384SRCBH	\$ 52,120.00	+ 1384FR	\$ 950.00
01-HX21394SRCBH	\$ 58,512.00	+ 1394FR	\$ 1,100.00
01-HX213114SRCBH	\$ 70,700.00	+ 1314FR	\$ 1,350.00

Auger can be substituted with any CB option

### FREIGHT & HANDLING

Horace, ND

Boone, IA

Decatur, IL

Grand Island, NE



Only available through the stock points listed above  
Does not include any fuel surcharges that may apply

### HX<sup>2</sup>16

Part #	List Price	Farm Ready	Package Net Price
01-HX21685SRH	\$ 92,912.00	+ 1685FR	\$ 1,550.00
01-HX216105SRH	\$ 108,896.00	+ 16105FR	\$ 2,100.00
01-HX216125SRH	\$ 121,738.00	+ 16125FR	\$ 2,450.00

### FREIGHT & HANDLING

Horace, ND

Boone, IA

Decatur, IL

Grand Island, NE



Only available through the stock points listed above  
Does not include any fuel surcharges that may apply

### FARM READY PACKAGES INCLUDE

Setup, Assembly, Farm Ready PDI check

ALL PRICES IN USD

# FARM READY

## READY TO WORK WHEN YOU ARE!

From our manufacturing floor to your farm, AGI Westfield augers with the Farm Ready package are ready to work the moment they leave our facility. Our Farm Ready package can be added to any bundle so your auger is ready to work.



### STX<sup>2</sup>

Part #	List Price		Farm Ready	Package Net Price
01-STX20836SRSPHCBH	\$ 23,387.00	+	0836FR (20 HP Kohler)	\$ 3,600.00
01-STX20841SRSPHCBH	\$ 24,474.00	+	0841FR (20 HP Kohler)	\$ 3,650.00
01-STX20846SRSPHCBH	\$ 25,490.00	+	0846FR (26.5 HP EFI Kohler)	\$ 4,300.00
01-STX20851SRSPHCBH	\$ 25,762.00	+	0851FR (26.5 HP EFI Kohler)	\$ 4,350.00
01-STX21036SRSPHCBH	\$ 25,416.00	+	1036FR (40 HP EFI Vanguard)	\$ 6,250.00
01-STX21041SRSPHCBH	\$ 26,029.00	+	1041FR (40 HP EFI Vanguard)	\$ 6,300.00
01-STX21046SRSPHCBH	\$ 28,915.00	+	1046FR (40 HP EFI Vanguard)	\$ 6,350.00
01-STX21051SRSPHCBH	\$ 30,058.00	+	1051FR (40 HP EFI Vanguard)	\$ 6,400.00

Refer to price pages for SPHCB components.

### FREIGHT & HANDLING

Horace, ND

Boone, IA

Decatur, IL

Grand Island, NE



Only available through the stock points listed above  
Does not include any fuel surcharges that may apply

### FARM READY PACKAGES INCLUDE

Setup, Assembly, Farm Ready PDI check, Motor and Battery

ALL PRICES IN USD



aggrowth.com

**AGI**  **HUTCHINSON  
MAYRATH**

 **HUTCHINSON  
MAYRATH**

# SWINGAWAY AUGERS

HX<sup>2</sup>

# GRAIN MOVING SOLUTIONS

AGI Hutchinson Mayrath is committed to providing farmers with industry leading products. The HX<sup>2</sup> Series features over 75 farm-proven performance enhancements designed to make your job easier. The HX<sup>2</sup> swingaway augers feature a heavy-duty steel frame, commercial strength trussing and updated durable boot. AGI Hutchinson Mayrath swingaway augers offer you unmatched performance and unparalleled ease of use.

## KEY UPDATES

### New open discharge spout

- More efficient flow, leading to a reduction in hp requirements and plugging

### Durable boot

- Separate abrasion resistant (AR) boot flighting with removable shafts provides a longer lifespan and makes servicing easier
- Tapered lower bearing increases lifespan (13")
- Hanger bearing to help support the boot flight reducing operation noise
- Easier inspections and servicing with dual side boot clean-out doors (13")
- Updated PTO holder for easier in-transport hook up (13")
- Updated hose holder (13")

### Responsive steerable axles

- Easy maneuvering around tight bin yards and corners
- Optional on 13" and standard on 16"

### Additional updates

- 30' tubes and flighting lessens connections and reduces noise
- Transition neck flight support (13" and 16") provides better alignment and improves lifespan
- Optional downspout
- Improved right-angle drive to increase gearbox stability (13")
- Right-angle drive compatible with speed reducer allows for 90-degree tractor positioning while reducing speeds from 1000 rpm to 540 rpm operating speed (13")



**2** YEAR WARRANTY



# HX<sup>2</sup> 10

UP TO 6,000 BPH  
53' - 83' LENGTHS



## KEY FEATURES

- New open discharge spout decreases horsepower requirements
- Aircraft cable trussing
- Stable scissor lift frame
- Strong a-frame support (53')
- Wide standing axles
- Abrasion resistant (AR) flighting at critical wear points

## OPTIONS

- Hydraulic hopper winch
- Electric and hydraulic power swing
- Reverser kit
- Corn screen
- Poly flex spout
- Right angle drive
- LED work lights





## Find the right auger

	HX <sup>2</sup> 10-53	HX <sup>2</sup> 10-63	HX <sup>2</sup> 10-73	HX <sup>2</sup> 10-83
TUBE GAUGE	12 ga			
TUBE CONNECTORS	Heavy-duty 3/16" (0.5 cm) angle flange			
MAIN FLIGHTING	9" (22.9 cm) OD x 7 ga stretched and welded with AR flighting at critical points			
AR FLIGHTING	1/4" (0.6 cm) on hopper, transition, incline tube, and boot			
FLIGHTING SHAFT	High strength 2" (5.1 cm) OD x 11 ga tubing square flight connection			
UPPER BEARING	2" (5.1 cm) taper roller bearing assembly			
LOWER BEARING	1 1/2" (3.8 cm) pillow block greaseable ball bearing			
TUBE TRUSSING	5/16" aircraft type galvanized steel cable	3/8" (1 cm) aircraft type galvanized steel cable		
HYDRAULIC LIFT	4" (10.2 cm) single acting cylinder			
UNDERCARRIAGE	3" (7.6 cm) x 11 ga A-frame	4" (10.2 cm) x 8" (20.3 cm) scissor lift		
AXLE	2 1/2" (6.4 cm) x 2 1/2" (6.4 cm) x 1/8" (0.3 cm) wall square tubing	3" (7.6 cm) x 6" (15.2 cm) tubing		
HUB	4-bolt agricultural type	6-bolt agricultural type		
TIRES	15" (38.1 cm) TRF	16" (40.6 cm) TRF		
PTO SHAFT	14E constant velocity with one shear bolt			35E constant velocity with one shear bolt
PARKING JACK	2,000 lbs (907.2 kg) side wind			
SPROCKET & CHAIN	Hardened tooth sprocket with HD #60 chain			
LOW PROFILE HOPPER DIMENSIONS	60" (152.4 cm) length x 40" (101.6 cm) width x 10" (25.4 cm) height with flat free tires			
PSI REQUIRED TO RAISE AUGER	1000 psi (68.9 bar)	1200 psi (82.7 bar)	1400 psi (96.5 bar)	1600 psi (110.3 bar)
HP REQUIRED (WITH DRY WHEAT)	45-50 hp	50-60 hp	55-65 hp	65-75 hp
WHEEL TREAD	106" (2.7 m)	132" (335.3 cm)	132" (335.3 cm)	132" - 180" (335.3 - 457.2 cm)
TRANSPORT HEIGHT (18" HITCH)	12' 6" (3.8 m)	13' (4 m)	13' (4 m)	13' (4 m)

## SPECIFICATIONS

	A	B	C	D	E	F	G	H	I	J		
<b>HX<sup>2</sup></b>	HEIGHT LOWERED	HEIGHT HALFWAY	HEIGHT RAISED	REACH LOWERED	REACH HALFWAY	REACH RAISED	HEIGHT AT LIFTARMS	HEIGHT AT WHEELS	REACH TO LIFTARMS	REACH TO WHEELS		
<b>1053</b>	10'-8" (3.3m)	24'-6" (7.5m)	36'-7" (11.2m)	27'-1" (8.3m)	25'-1" (7.6m)	22'-5" (6.8m)	14'-10" (4.5m)	16'-10" (5.1m)	21'-11" (6.7m)	24'-7" (7.5m)		
	A	B	C	D	E	F	G	H	I	J		
<b>HX<sup>2</sup></b>	HEIGHT LOWERED	HEIGHT HALFWAY	HEIGHT RAISED	HEIGHT LOWERED	HEIGHT HALFWAY	HEIGHT RAISED	REACH LOWERED	REACH HALFWAY	REACH RAISED	REACH LOWERED	REACH HALFWAY	REACH RAISED
<b>1063</b>	11'-3" (3.4 m)	28'-10" (8.8 m)	43'-8" (13.3 m)	6'-9" (2.1 m)	14'-8" (4.5 m)	22'-5" (6.8 m)	32'-9" (10 m)	31'-1" (9.5 m)	26'-4" (8 m)	32'-9" (10 m)	24'-11" (7.6 m)	30'-1" (9.2 m)
<b>1073</b>	10'-11" (3.3 m)	31'-3" (9.5 m)	48'-1" (14.7 m)	6'-9" (2.1 m)	16'-4" (5 m)	25'-4" (7.7 m)	36'-8" (11.1 m)	34'-11" (10.6 m)	30'-1" (9.2 m)	36'-8" (11.2 m)	34'-1" (10.4 m)	29'-4" (8.9 m)
<b>1083</b>	11'-1" (3.4 m)	35'-4" (10.8 m)	55'-3" (16.8 m)	6'-9" (2.1 m)	18'-1" (5.5 m)	28'-6" (8.7 m)	42'-3" (12.9 m)	40'-1" (12.2 m)	33'-11" (10.3 m)	42'-3" (12.9 m)	38'-5" (11.7 m)	31'-1" (9.5 m)

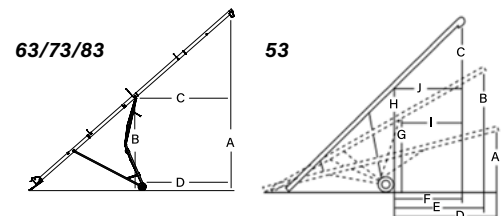

Heights measured from bottom of auger spout to ground.

# HX<sup>2</sup> 13

UP TO 11,000 BPH  
64' - 114' LENGTHS



## KEY FEATURES

- New open discharge spout decreases horsepower requirements
- Rigid steel trussing (84' and up)
- Stable scissor lift frame (74'-94')
- Strong A-frame support (64' and 114')
- Abrasion resistant (AR) flighting at critical wear points

## OPTIONS

- Steerable axles
- Hydraulic hopper winch
- Electric and hydraulic power swing
- X-Tend hopper
- X-Over hopper
- Poly flex spout
- Speed reducer-reverser
- Reverser kit
- Corn screen
- Right angle drive
- Transport lights
- LED work lights



## Find the right auger

	HX <sup>2</sup> 13-64	HX <sup>2</sup> 13-74	HX <sup>2</sup> 13-84	HX <sup>2</sup> 13-94	HX <sup>2</sup> 13-114
TUBE GAUGE	12 ga				
TUBE CONNECTORS	Heavy-duty ¼" (0.6 cm) angle flange				
MAIN FLIGHTING	11 ¾" (29.8 cm) OD x ¼" (0.6 cm) stretched and welded with AR flighting at critical points.				
AR FLIGHTING	¼" (0.6 cm) on hopper, transition, incline tube, and boot				
FLIGHTING SHAFT	High strength 3" (7.6 cm) OD x 11 ga tubing square flight connection				
UPPER BEARING	2" (5.1 cm) taper roller bearing assembly				
GREASELESS HANGER BEARING FOR BOOT (NEW)	1 ⅞" (4.9 cm) ID, triple seal				
LOWER BEARING	Custom 2" (5.1 cm) taper roller bearing assembly				
TUBE TRUSSING	¾" (1 cm) aircraft type galvanized steel cable		2 ½" (6.4 cm) steel tube		
HYDRAULIC LIFT	Two 4" (10.2 cm) single acting cylinders			Two 4 ½" (11.4 cm) single acting cylinders	Two 4 ½" (11.4 cm) cylinders with ¾" (1 cm) aircraft cable
UNDERCARRIAGE	4" (10.2 cm) x 11 ga A-frame	4" (10.2 cm) x 8" (20.3 cm) scissor lift			A-frame 4" (10.2 cm) x 8" (20.3 cm) HSS tubing
AXLE	3 ½" (8.9 cm) x 3 ½" (8.9 cm) square tube				
HUB	6-bolt agricultural type				
TIRES	16" (40.6 cm) TRF				
PTO SHAFT	35E constant velocity with ⅜" (1 cm) shear bolt		55E constant velocity with 2-bolt shear		
PARKING JACK	5000 lbs (2,268 kg) side wind				
SPROCKET & CHAIN	Hardened tooth sprocket with HD #80 chain				
LOW PROFILE HOPPER DIMENSIONS	60" (152.4 cm) length x 40" (101.6 cm) width x 10" (25.4 cm) height with flat free tires				
PSI REQUIRED TO RAISE AUGER	1600 psi (110.3 bar)	1500 psi (103.4 bar)	1950 psi (134.4 bar)	2050 psi (141.3 bar)	2100 psi (144.8 bar)
HP REQUIRED (WITH DRY WHEAT)	85-100 hp	110-125 hp	115-135 hp	125-165 hp	140-185 hp
WHEEL TREAD	124" (315 cm)		146" - 182" (370.8 cm - 462.3 cm)		
TRANSPORT HEIGHT (18" HITCH)	13' 2" (4 m)	11' 7" (3.5 m)	12' (3.7 m)	12' (3.7 m)	14' 5" (4.4 m)

## SPECIFICATIONS

HX <sup>2</sup>	A	B	C	D	E	F	G	H	I	J		
HX <sup>2</sup>	HEIGHT LOWERED	HEIGHT HALFWAY	HEIGHT RAISED	REACH LOWERED	REACH HALFWAY	REACH RAISED	HEIGHT AT LIFTARMS	HEIGHT AT WHEELS	REACH TO LIFTARMS	REACH TO WHEELS		
<b>1364</b>	10'-2" (3.1m)	26' (7.9m)	40'-3" (12.3m)	31'-1" (9.5m)	29'-11" (9.1m)	27'-8" (8.4m)	15'-10" (4.8m)	17'-8" (5.4m)	26'-7" (8.1m)	31'-11" (9.7m)		
HX <sup>2</sup>	A	B	C	D	E	F	G	H	I	J		
HX <sup>2</sup>	HEIGHT LOWERED	HEIGHT HALFWAY	HEIGHT RAISED	HEIGHT LOWERED	HEIGHT HALFWAY	HEIGHT RAISED	REACH LOWERED	REACH HALFWAY	REACH RAISED	REACH LOWERED	REACH HALFWAY	REACH RAISED
<b>1374</b>	8'-9" (2.7 m)	31'-2" (9.5 m)	49'-6" (15.1 m)	4'-6" (1.4 m)	12'-7" (3.8 m)	24'-4" (7.4 m)	39'-8" (12.1 m)	38'-3" (11.7 m)	32'-6" (9.9 m)	39'-8" (12.1 m)	36'-7" (11.2 m)	30'-6" (9.3 m)
<b>1384</b>	8'-8" (2.6 m)	34'-8" (10.6 m)	55'-8" (17 m)	4'-6" (1.4 m)	15'-9" (4.8 m)	27'-5" (8.4 m)	44'-11" (13.7 m)	43'-3" (13.2 m)	36'-9" (11.2 m)	44'-11" (13.7 m)	41'-6" (12.6 m)	34'-5" (10.5 m)
<b>1394</b>	8'-9" (2.7 m)	38'-3" (11.7 m)	60'-11" (18.6 m)	4'-6" (1.4 m)	17'-1" (5.2 m)	30' (9.1 m)	50'-2" (15.3 m)	48'-3" (14.7 m)	40'-11" (12.5 m)	50'-2" (15.3 m)	46'-4" (14.1 m)	38'-5" (11.7 m)
HX <sup>2</sup>	A	B	C	D	E	F	G	H	I	J		
HX <sup>2</sup>	HEIGHT LOWERED	HEIGHT HALFWAY	HEIGHT RAISED	REACH LOWERED	REACH HALFWAY	REACH RAISED	HEIGHT AT LIFTARMS	HEIGHT AT WHEELS	REACH TO LIFTARMS	REACH TO WHEELS		
<b>13114</b>	12' (3.7 m)	41'-2" (12.5 m)	68'-11" (21 m)	56'-1" (17.1 m)	53'-4" (16.3 m)	46'-2" (14.1 m)	27'-6" (8.4 m)	33'-11" (10.3 m)	38'-3" (11.7 m)	47'-1" (14.4 m)		

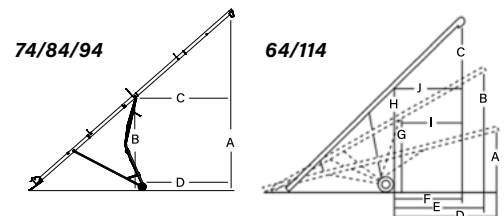

Heights measured from bottom of auger spout to ground.

# HX<sup>2</sup> 16

UP TO 23,000 BPH  
85' - 125' LENGTHS



See new  
axles  
in action

## KEY FEATURES

- New open discharge spout decreases horsepower requirements
- Durable boot updates
- Rigid steel trussing
- Stable A-frame support
- Standard steerable axles

## OPTIONS

- X-Tend hopper
- Poly flex spout



## Find the right auger

	HX <sup>2</sup> 16-85	HX <sup>2</sup> 16-105	HX <sup>2</sup> 16-125
TUBE GAUGE	10 ga		
TUBE CONNECTORS	¼" (0.6 cm) angle flange		
MAIN FLIGHTING	15" (38.1 cm) x ¼" (0.6 cm) stretched and welded		
WEAR EDGE TECHNOLOGY™ (REINFORCED FLIGHT)	¼" (0.6 cm) main flighting with Wear Edge Technology™ on critical grain transfer points		
AR FLIGHTING	¼" (0.6 cm) on boot		
FLIGHTING SHAFT	3.5" (8.9 cm) x 11 ga tubing; square flight connector		
GREASELESS HANGER BEARING FOR BOOT (NEW)	2 ⅜" (6 cm) ID, triple seal		
UPPER BEARING	2" (5.1 cm) taper roller bearing assembly		
SPEED REDUCER GEARBOX	Enclosed, cast casing, 1000 rpm reducing gearbox (540 rpm) with reversing capability		
TUBE TRUSSING	3.5" (8.9 cm) x 11 ga tubing; ½" (1.3 cm) cable stays		
HYDRAULIC LIFT	2 x 4 ½" (11.4 cm) cylinder with ⅜" (1 cm) cable	2 x 6 ½" (16.5 cm) bore cylinders; ½" (1.3 cm) aircraft cable	
UNDERCARRIAGE	4" (10.2 cm) x 8" (20.3 cm) HSS tubing		
AXLE	4" (10.2 cm) x 4" (10.2 cm) x ⅜" (0.5 cm) tubing; 4" (10.2 cm) x 4" (10.2 cm) x ¼" (0.6 cm) on extensions		
HUB	8-bolt agricultural type		
TIRES	22.5" (57.2 cm) agricultural tires		
PTO SHAFT	50E double CV with 2-bolt shear		
PARKING JACK	12,000 lbs (5443.1 kg)		
LOW PROFILE HOPPER DIMENSIONS	68" (172.7 cm) length x 46 ½" (118.1 cm) width x 11" (27.9 cm) height with flat free tires		
PSI REQUIRED TO RAISE AUGER	1800 psi (124.1 bar)	1700 psi (117.2 bar)	2000 psi (137.9 bar)
HP REQUIRED (WITH DRY WHEAT)	150 - 175 hp	170 - 200 hp	195 - 225 hp
WHEEL TREAD	148" - 182" (375.9 - 462.3 cm)		
TRANSPORT HEIGHT (18" HITCH)	15' 6" (4.7 m)	15' 6" (4.7 m)	17' 6" (5.3 m)

## SPECIFICATIONS

	A	B	C	D	E	F	G	H	I	J
<b>HX<sup>2</sup></b>	HEIGHT LOWERED	HEIGHT HALFWAY	HEIGHT RAISED	REACH LOWERED	REACH HALFWAY	REACH RAISED	HEIGHT AT LIFTARMS	HEIGHT AT WHEELS	REACH TO LIFTARMS	REACH TO WHEELS
<b>1685</b>	12'-7" (3.8 m)	33'-4" (10.1 m)	47'-3" (14.4 m)	46' (14 m)	43'-4" (13.2 m)	39'-10" (12.1 m)	23'-8" (7.2 m)	28'-7" (8.7 m)	26'-4" (8 m)	31'-9" (9.7 m)
<b>16105</b>	12' (3.7 m)	42'-11" (13.1 m)	77'-5" (23.6 m)	54'-10" (16.7 m)	51'-3" (15.6 m)	40'-7" (12.4 m)	30'-2" (9.2 m)	36'-5" (11.1 m)	32'-1" (9.8 m)	42'-8" (13 m)
<b>16125</b>	14'-3" (4.3 m)	48'-6" (14.8 m)	87'-10" (26.8 m)	68'-8" (20.9 m)	63'-8" (19.4 m)	48'-9" (14.9 m)	31'-6" (9.6 m)	37'-1" (11.3 m)	44'-4" (13.5 m)	56'-9" (17.3 m)

Heights measured from bottom of auger spout to ground.

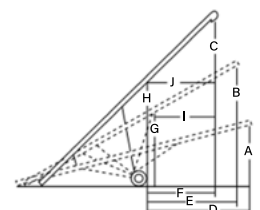

# HOPPER

## OPTIONS



See X-Over  
in action

### **X-TEND**

13" // 16"

#### KEY FEATURES

- Retracts and moves side-to-side
- Low profile hopper with dual flighting
- Hydraulic controls

### **X-OVER**

13"

#### KEY FEATURES

- Drive over belt-driven hopper
- Reinforced drive over deck and ramps
- Mechanical drive hopper (NEW)

### **POWER SWING**

10" // 13" // 16"

#### KEY FEATURES

- 12V remote electric or hydraulic drive





See X-Tend  
in action



Part numbers are set up as Hutchinson part numbers. To order Mayrath, change the last "H" of the part number to an "M".

Part Number	Description	Weight (lbs)	Price
<b>HX 8 x 51 AUGER</b>			
01-HX0851SRH	Basic Auger (Painted Silver)	1870	\$16,621.00
<b>HX 8 x 61 AUGER</b>			
01-HX0861SRH	Basic Auger (Painted Silver)	2110	\$17,953.00
<b>HX 8 x 71 AUGER</b>			
01-HX0871SRH	Basic Auger (Painted Silver)	2330	\$19,799.00
<b>HX<sup>2</sup> 10 x 36 AUGER</b>			
01-HX21036GSRH	Auger with Standard Hopper Painted Silver (A-Frame Lift)	2217	\$17,000.00
01-HX21036SRH	Auger with Low-Profile Hopper Painted Silver (A-Frame Lift)	2399	\$18,700.00
<b>HX<sup>2</sup> 10 x 53 AUGER</b>			
01-HX21053SRH	Basic Auger Painted Silver	3044	\$24,095.00
<b>HX<sup>2</sup> 10 x 63 AUGER</b>			
01-HX21063SRH	Basic Auger (Painted Silver)	4028	\$26,025.00
01-HX21063SRCBH	Complete Bundle with Electric Power Swing (Silver)	4388	\$34,062.00
01-HX21063SRCBHH	Complete Bundle with Hydraulic Power Swing (Silver)	4408	\$32,031.00
<b>Complete Bundle Includes: Low Profile Hopper, Hydraulic Hopper Winch, Work Light Kit</b>			
<b>HX<sup>2</sup> 10 x 73 AUGER</b>			
01-HX21073SRH	Basic Auger (Painted Silver)	4375	\$27,468.00
01-HX21073SRCBH	Complete Bundle with Electric Power Swing (Silver)	4738	\$35,505.00
01-HX21073SRCBHH	Complete Bundle with Hydraulic Power Swing (Silver)	4758	\$33,474.00
<b>Complete Bundle Includes: Low Profile Hopper, Hydraulic Hopper Winch, Work Light Kit</b>			
<b>HX<sup>2</sup> 10 x 83 AUGER</b>			
01-HX21083SRH	Basic Auger (Painted Silver)	4793	\$30,537.00
01-HX21083SRCBH	Complete Bundle with Electric Power Swing (Silver)	5153	\$38,574.00
01-HX21083SRCBHH	Complete Bundle with Hydraulic Power Swing (Silver)	5173	\$36,543.00
<b>Complete Bundle Includes: Low Profile Hopper, Hydraulic Hopper Winch, Work Light Kit</b>			
<b>OPTIONS</b>			
05-A148	10" Corn Screen	27	\$688.00
05-A164	Poly Bucket Flex Spout, 36" - 5 Section, Fits 8/10" Augers	14	\$238.00
05-A184	MK100/MKX130 Low-Profile Hopper Tarp	9	\$423.00
05-A271	Additional Remote Control	1	\$376.00
05-A282	No Snag Spout, 3 Section, Fits 10" Augers	8	\$310.00
05-A292	HX10 Reverser Kit	43	\$1,035.00
05-A293	HX10 Right Angle Drive	133	\$3,197.00
05-A296	HX10 Hydraulic Hopper Lift Kit	76	\$2,192.00
05-A331	Hopper Weight for Lift Cable	15	\$136.00
05-A348	1053/63 Work Light Kit	21	\$789.00
05-A350	1073 Work Light Kit	17	\$789.00
05-A352	1083 Work Light Kit	18	\$789.00
05-A362	HX10 Hydraulic Landing Gear Power Swing	310	\$3,525.00
05-A363	HX10 Remote Electric Landing Gear Power Swing	290	\$5,556.00
05-A448	HX10 Spout Head-Hose Ring Replacement	17	\$264.00
05-A515	MKX2/X2/HX2 10" Parts Kit		\$290.00

PRICES DO NOT INCLUDE SALES TAX  
 SUBJECT TO CHANGE  
 ALL PRICES IN USD \$



Part numbers are set up as Hutchinson part numbers. To order Mayrath, change the last "H" of the part number to an "M".

Part Number	Description	Weight (lbs)	Price
-------------	-------------	--------------	-------

05-A525	HX2 10" Low-Profile Hopper Assembly	389	\$3,374.00
---------	-------------------------------------	-----	------------

### 10" RETURN/CREDIT

14-X100	*Credit for 1063/73 Complete PTO Return		\$687.00
14-X103	*Credit for 1083 Complete PTO Return		\$1,206.00

### HX<sup>2</sup> 13 x 64 AUGER

01-HX21364SRH	Basic Auger (Painted Silver) - *Hydraulic hopper lift kit no longer included*	4828	\$37,404.00
---------------	---	------	-------------

### HX<sup>2</sup> 13 x 74 AUGER

01-HX21374SRH	Basic Auger (Painted Silver) - *Hydraulic hopper lift kit no longer included*	6669	\$40,186.00
01-HX21374SRLH	Auger with 15' Swing Tube (Painted Silver)	6888	\$42,025.00
01-HX21374SRCBH	Complete Bundle with Electric Power Swing (Painted Silver)	7101	\$48,220.00
01-HX21374SRCBLH	Complete Bundle with 15' Electric Power Swing Tube (Painted Silver)	7322	\$50,059.00
01-HX21374SRCBHH	Complete Bundle with Hydraulic Power Swing (Painted Silver)	7111	\$46,171.00
01-HX21374SRCBHLH	Complete Bundle with 15' Hydraulic Power Swing Tube (Painted Silver)	7332	\$48,010.00
01-HX21374SRCBRRH	Complete Bundle with Electric Power Swing and Reducer/Reverser	7367	\$54,202.00
01-HX21374SRXTENDRRH	Complete Bundle with X-Tend Hopper and Reducer/Reverser	7387	\$71,454.00
01-HX21374SRXTENDH	Auger with X-Tend Hopper (Painted Silver)	7270	\$65,472.00

**Complete Bundle Includes: Low Profile Hopper, Hydraulic Hopper Winch, and Work Light Kit**

**Reducer/Reverser Bundles Include 21 Spline CV-PTO (05-A219)**

### HX<sup>2</sup> 13 x 84 AUGER

01-HX21384SRH	Basic Auger (Painted Silver) - *Hydraulic hopper lift kit no longer included*	7442	\$44,086.00
01-HX21384SRLH	Auger with 15' Swing Tube (Painted Silver)	7677	\$45,944.00
01-HX21384SRCBH	Complete Bundle with Electric Power Swing (Painted Silver)	7877	\$52,120.00
01-HX21384SRCBLH	Complete Bundle with 15' Electric Power Swing Tube (Painted Silver)	8113	\$53,978.00
01-HX21384SRCBHH	Complete Bundle with Hydraulic Power Swing (Painted Silver)	7887	\$50,071.00
01-HX21384SRCBHLH	Complete Bundle with 15' Hydraulic Power Swing Tube (Painted Silver)	8123	\$51,929.00
01-HX21384SRCBRRH	Complete Bundle with Electric Power Swing and Reducer/Reverser	8297	\$58,197.00
01-HX21384SRXTENDRRH	Complete Bundle with X-Tend Hopper and Reducer/Reverser	8176	\$71,866.00
01-HX21384SRXTENDH	Auger with X-Tend Hopper (Painted Silver)	8076	\$65,789.00

**Complete Bundle Includes: Low Profile Hopper, Hydraulic Hopper Winch, Transport and Work Light Kit**

**Reducer/Reverser Bundles Include 21 Spline CV-PTO (05-A246)**

### HX<sup>2</sup> 13 x 94 AUGER

01-HX21394SRH	Basic Auger (Painted Silver) - *Hydraulic hopper lift kit no longer included*	7933	\$50,465.00
01-HX21394SRLH	Auger with 15' Swing Tube (Painted Silver)	8168	\$52,354.00
01-HX21394SRCBH	Complete Bundle with Electric Power Swing (Painted Silver)	8371	\$58,512.00
01-HX21394SRCBLH	Complete Bundle with 15' Electric Power Swing Tube (Painted Silver)	8606	\$60,401.00
01-HX21394SRCBHH	Complete Bundle with Hydraulic Power Swing (Painted Silver)	8381	\$56,463.00
01-HX21394SRCBHLH	Complete Bundle with 15' Hydraulic Power Swing Tube (Painted Silver)	8616	\$58,352.00
01-HX21394SRCBRRH	Complete Bundle with Electric Power Swing and Reducer/Reverser	8910	\$64,589.00
01-HX21394SRXTENDRRH	Complete Bundle with X-Tend Hopper and Reducer/Reverser	8669	\$78,698.00
01-HX21394SRXTENDH	Auger with X-Tend Hopper (Painted Silver)	8567	\$72,621.00
01-HX21394SRXOVERH	Auger with X-Over Hopper (Painted Silver)	9284	\$72,621.00

**Complete Bundle Includes: Low Profile Hopper, Hydraulic Hopper Winch, Transport and Work Light Kit**

**Reducer/Reverser Bundles Include 21 Spline CV-PTO (05-A246)**

### HX<sup>2</sup> 13 x 114 AUGER

01-HX213114SRH	Basic Auger - A-Frame Lift - Hydraulic hopper lift kit no longer included	9036	\$62,653.00
01-HX213114SRLH	Auger with 15' Swing Tube (Painted Silver)	9271	\$64,291.00

Part numbers are set up as Hutchinson part numbers. To order Mayrath, change the last "H" of the part number to an "M".

Part Number	Description	Weight (lbs)	Price
01-HX213114SRCBH	Complete Bundle with Electric Power Swing (Painted Silver)	9473	\$70,700.00
01-HX213114SRCBLH	Complete Bundle with 15' Electric Power Swing Tube (Painted Silver)	9713	\$72,338.00
01-HX213114SRCBHH	Complete Bundle with Hydraulic Power Swing (Painted Silver)	9483	\$68,651.00
01-HX213114SRCBHLH	Complete Bundle with 15' Hydraulic Power Swing Tube (Painted Silver)	9723	\$70,289.00
01-HX213114SRCBRRH	Complete Bundle with Electric Power Swing and Reducer/Reverser	9504	\$76,777.00
01-HX213114SRXTENDRRH	Complete Bundle with X-Tend Hopper and Reducer/Reverser	10013	\$91,208.00
01-HX213114SRXTENDH	Auger with X-Tend Hopper (Painted Silver)	9922	\$85,131.00
01-HX213114SRXOVERH	Auger with X-Over Hopper (Painted Silver)	10625	\$85,131.00

**Complete Bundle Includes: Low Profile Hopper, Hydraulic Hopper Winch, Transport and Work Light Kit**

**Reducer/Reverser Bundles Include 21 Spline CV-PTO (05-A246)**

## OPTIONS

05-A175	Poly Bucket Spout, 49" - 5 Section, Fits 13" Augers	21	\$426.00
05-A184	MK100/MKX130 Low-Profile Hopper Tarp	9	\$423.00
05-A185	13" Corn Screen	33	\$1,007.00
05-A219	CV-PTO 1/2 Shaft For HX1374 Models (21 Spline)	30	\$1,193.00
05-A220	CV-PTO 1/2 Shaft For HX1374 Models (20 Spline)	30	\$1,325.00
05-A246	CV-PTO 1/2 Shaft For HX13-84/94/114 Models (21 Spline) 55E	30	\$1,383.00
05-A247	CV-PTO 1/2 Shaft For HX13-84/94/114 Models (20 Spline) 55E	33	\$1,477.00
05-A262	HX13 1000 RPM Reducer/Reverser	311	\$5,549.00
05-A263	HX13 Reverser Kit	49	\$1,426.00
05-A266	HX13 Hydraulic Hopper Lift Kit	75	\$2,192.00
05-A271	Additional Remote Control	1	\$376.00
05-A283	No Snag Spout, 3 Section, Fits 13" Augers	19	\$498.00
05-A331	Hopper Weight for Lift Cable	15	\$136.00
05-A333	HX13 Hydraulic Landing Gear Power Swing	320	\$3,539.00
05-A334	HX13 Remote Electric Landing Gear Power Swing	310	\$5,588.00
05-A341	X1374 Transport and Work Lights Bundle	64	\$1,254.00
05-A349	1364 Work Light Kit		\$789.00
05-A353	1384 Transport and Work Lights Bundle	61	\$1,254.00
05-A355	1394 Transport and Work Lights Bundle	62	\$1,267.00
05-A357	13114 Transport and Work Lights Bundle	35	\$1,267.00
05-A383	X-Tend Swing Assembly	1740	\$29,991.00
05-A449	HX13 Spout Head-Hose Ring Replacement	22	\$356.00
05-A510RD	HX2/MKX2 13-114 Auger Steer Kit *NEW*	431	\$4,099.00
05-A512RD	HX2 13-94 Auger Steer Kit *NEW*	437	\$4,099.00
05-A513RD	HX2/MKX2 13" Right Angle Drive 540RPM *NEW*		\$6,093.00
05-A514RD	HX2/MKX2 13" Right Angle Drive works with Speed Reducer *NEW*		\$6,203.00
05-A516	MKX2/X2/HX2 13" Parts Kit		\$371.00
05-A526	HX2 13" Low-Profile Hopper Assembly	472	\$3,571.00

## 13" RETURN/CREDIT

14-X101	*Credit for 1364/74 Complete PTO Return		\$1,526.00
14-X104	*Credit for 1364/74 Tractor Half PTO Return		\$760.00
14-X108	*Credit for 1384/94/114 Complete PTO Return		\$2,834.00
14-X109	*Credit for 1384/94/114 Tractor Half PTO Return		\$890.00
14-X123	*Credit for 13" X-Tend Conversion		\$5,199.00

## HX<sup>2</sup> 16 x 85 AUGER

01-HX21685SRH	Complete Auger (Painted Silver)	12579	\$92,912.00
01-HX21685SRXTENDH	Complete Auger with HX-Tend Hopper	12832	\$112,467.00

**All 16" augers come as a complete bundles and include: AUGER STEER, power swing, speed reducing gearbox with 20 spline PTO shaft, hydraulic hopper winch, transport and work light bundle**

Part numbers are set up as Hutchinson part numbers. To order Mayrath, change the last "H" of the part number to an "M".

Part Number	Description	Weight (lbs)	Price
<b>HX<sup>2</sup> 16 x 105 AUGER</b>			
01-HX216105SRH	Complete Auger (Painted Silver)	15588	\$108,896.00
01-HX216105SRXTENDH	Complete Auger with HX-Tend Hopper	15841	\$128,400.00

*All 16" augers come as a complete bundles and include: AUGER STEER, power swing, speed reducing gearbox with 20 spline PTO shaft, hydraulic hopper winch, transport and work light bundle*

<b>HX<sup>2</sup> 16 x 125 AUGER</b>			
01-HX216125SRH	Complete Auger (Painted Silver)	17098	\$121,738.00
01-HX216125SRXTENDH	Complete Auger with HX-Tend Hopper	17352	\$140,820.00

*All 16" augers come as a complete bundles and include: AUGER STEER, power swing, speed reducing gearbox with 20 spline PTO shaft, hydraulic hopper winch, transport and work light bundle*

<b>OPTIONS</b>			
05-A280	16" Poly Bucket Spout	34	\$611.00
05-A281	HX160 21 Spline Tractor Half PTO	51	\$2,135.00
05-A284	No Snag Spout, 3 Section, Fits 16" Augers	26	\$641.00
05-A305	HX160 Low Profile Hopper Tarp		\$456.00
05-A354	1685 Transport and Work Lights Bundle	30	\$1,248.00
05-A356	16105 Transport and Work Lights Bundle	64	\$1,267.00
05-A358	16125 Transport and Work Lights Bundle	30	\$1,308.00
05-A450	HX16 Spout Head-Hose Ring Replacement	47	\$408.00
05-A517	MKX2/X2/HX2 16" Parts Kit		\$215.00
05-A518	HX2 16" Right Angle Drive *NEW*		*call for price

<b>16" RETURN/CREDIT</b>			
14-X120	*Credit for 20 Spline Tractor Half PTO Return		\$1,754.00

WRX  
TRUCK AUGER



## DRIVE OPTIONS



### MD

#### Motor Drive

The engine mounts crosswise for easy starting from the side of the auger. The motor mount is self-leveling at all auger positions keeping the motor at the correct working angle. The double belt drive with adjustable tension provides better traction and can be easily replaced.

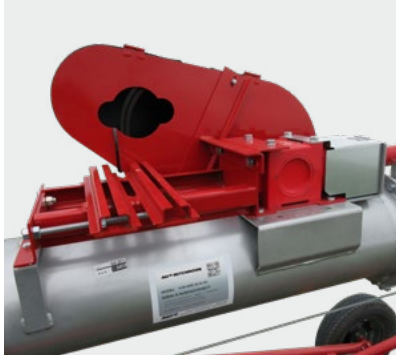

### EMD

#### Electric Motor Drive

The motor mounts firmly to the gearbox and auger tube, keeping it in place and preventing damage. To provide the best possible traction, our models up to 41' have been retrofitted with a double belt drive, while our models of 46' or greater feature a triple belt drive.



### PTO-SD

#### PTO Shaft Drive

The gearbox is connected directly to the driveshaft and offers the convenience and flexibility of using it for left or right hand drive. The PTO-SD comes with a non-separable 60" PTO driveline that extends to 80" and includes a driveline transport saddle to make moving the unit easier.



### Hydraulic Drive

#### Hydraulic Drive

The hydraulic drive auger option uses the tractor's hydraulics to run and has clips to hold hydraulic hoses during use and transport. This drive option provides a smooth, trouble-free operation.



### PTO-BD

#### PTO Belt Drive

The belt drive runs from the gearbox to the jackshaft near the auger wheels - keeping the auger intake away from the tractor, allowing for more working room and longer bin reach. The drive can be positioned to left or right-hand drive and the non-separable 48" PTO can be extended to 68" and is guided by an anti-belt-whip. A driveline saddle holds the drive in place while in transport.

## FEATURES



### Winch

Complete with an automatic brake, the hand winch is sized and geared to match each specific auger - giving you the power to raise and lower your auger manually.

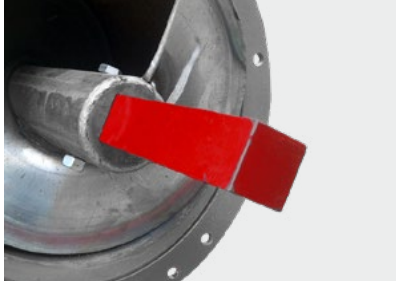

### Flighting

The WRX Series uses one-bolt flight connections to ensure the flighting maintains proper alignment for smooth operation. The 8" models feature a round flighting connection and the 10" models use a square connection.



### Solid Tube Drive Guard

This completely enclosed driveline offers a cleaner look and better protection from the elements. This helps keep your driveline intact for longer, preventing costly repairs. Wood Bearings can still be replaced with split bearings.

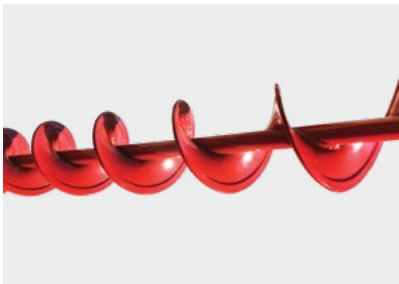

### Wear Edge Technology™

Wear Edge Technology™ extends the life of your flighting, providing an extra layer of steel welded to critical wear points. As a result, flighting lasts longer and needs to be replaced less often - saving you time and money.



### Gearbox

Our gearboxes have forged steel gears with tapered roller bearings running in oil for years of dependable service.



### Undercarriage

Undercarriages of heavy steel tubing are designed for each specific auger length for better balance and stability. Upper lift arms sit back from the axle and quickly tuck away for excellent bin eave clearance. Wide axles provide added stability. High-speed wheels with cast iron hubs and tapered roller bearings come standard.

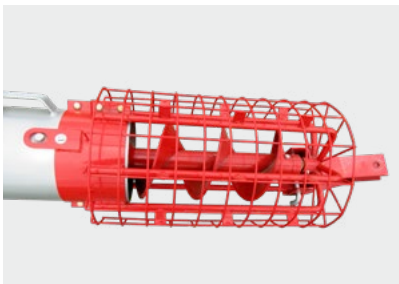

### Intake

The shielded auger intake has a long, one-pin, quick-remove clevis that is easily replaced. Intake flighting has welded Wear Edge Technology™ for long life with special low pitch for proven added capacity. Greaseable bushing centers flight reducing vibration and wear.

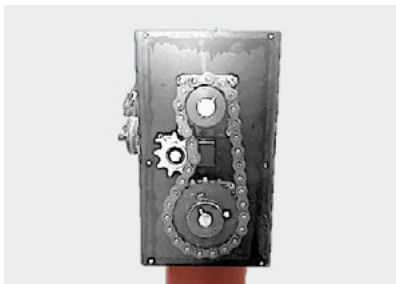

### Lubricated Upper Drive

Heavy-duty hardened steel sprockets and high-speed roller chain are sized to match auger length and diameter. Lubricated upper drive extends the life of sprockets and drive chain.

**OPTIONS**

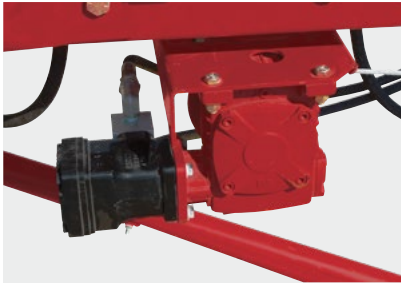

**Hydraulic Winch**

This high capacity hydraulic winch comes complete with an automatic brake and allows you to raise and lower the auger with ease.

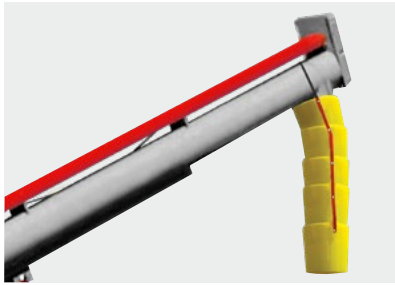

**Flex Spout**

With five bucket sections, the flex spout directs grain flow and reduces spillage, so nothing is wasted. Available in polyethylene.



**Poly Hoppers**

Corrosion resistant and lightweight poly hoppers allow for easy grain transfer with minimal spillage, providing a durable and flexible option.



Bin Hopper Dimensions: 36" Long x 36" Wide

**Steel Intake Hoppers**

The self-leveling steel intake hopper has a tapered transition neck to direct grain from the hopper into the auger, removable access plate for easy clean-out, a tow hitch and stabilizer bar. Optional wheel kit available.



**Wheel Kit**

The Wheel Kit helps move the auger into position easily and works best when using a steel intake hopper.



**Enclosed Collapsible Hopper**

The new enclosed collapsible hopper is a cost effective option that delivers ease of use and maximized efficiency. The hopper mounts over your existing intake cage and releases with the removal of two hitch pins. A removable access door makes for easy clean-out. Comes complete with tow hitch.

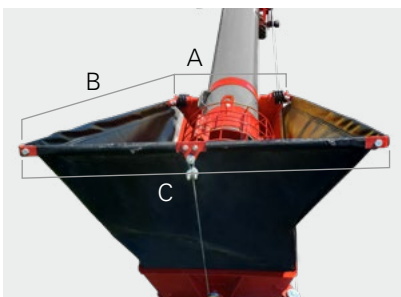

**Enclosed Collapsible Hopper Specifications**

	8"	10"
<b>A</b>	16"	18.5"
<b>B</b>	36.5"	36.5"
<b>C</b>	33"	35.5"

	8"	10"
<b>COLLAPSED HEIGHT</b>	8"	9.5"
<b>TOTAL HEIGHT</b>	26.5"	27.5"

**HEIGHT | REACH | WHEEL | SPECIFICATIONS**

	A	B	C	D	E	F	G	H	I	
	HEIGHT LOWERED	HEIGHT HALFWAY	HEIGHT RAISED	REACH LOWERED	REACH HALFWAY	REACH RAISED	HEIGHT AT LIFTARMS	HEIGHT AT WHEELS	REACH TO LIFTARMS	WHEEL TREAD
31'	8' 1"	14' 9"	20' 9"	12' 7"	11' 4"	9' 4"	8' 9"	12' 5"	9' 7"	70"
31' MD	8' 1"	11' 10"	15' 6"	12' 7"	12' 0"	11' 5"	7' 8"	9' 3"	9' 3"	70"
36'	9' 8"	17' 9"	24' 7"	15' 9"	13' 2"	10' 1"	10' 8"	15' 6"	9' 7"	88"
36' MD	9' 8"	15' 1"	18' 2"	15' 9"	14' 2"	13' 0"	9' 9"	9' 9"	10' 8"	88"
36' BD	10' 11"	17' 8"	24' 6"	14' 8"	13' 1"	10' 9"	11' 1"	15' 3"	10' 5"	88"
41'	10' 4"	20' 3"	29' 1"	17' 9"	15' 11"	12' 9"	11' 6"	16' 4"	12' 9"	88"
41' MD	10' 4"	15' 0"	20' 3"	17' 9"	17' 2"	15' 11"	9' 9"	11' 9"	13' 1"	88"
41' BD	11' 7"	20' 6"	28' 5"	17' 0"	15' 5"	12' 7"	11' 9"	16' 5"	12' 7"	88"
46'	10' 5"	20' 10"	31' 3"	19' 5"	16' 0"	11' 1"	13' 9"	19' 0"	9' 3"	106"
46' BD	11' 5"	22' 6"	31' 5"	17' 9"	15' 10"	12' 8"	14' 5"	19' 9"	11' 8"	106"
51'	10' 5"	24' 8"	35' 0"	22' 1"	19' 7"	16' 5"	14' 3"	19' 0"	18' 0"	106"
51' BD	11' 11"	24' 8"	35' 6"	21' 7"	19' 7"	15' 10"	14' 6"	20' 4"	15' 0"	106"
56'	11' 5"	25' 1"	37' 5"	26' 5"	22' 7"	17' 2"	15' 6"	22' 2"	13' 8"	112"
61'	11' 0"	27' 9"	40' 1"	26' 6"	22' 6"	18' 7"	16' 7"	22' 8"	20' 10"	112"
71'	12' 4"	30' 10"	46' 5"	31' 3"	28' 2"	22' 9"	19' 1"	26' 10"	24' 6"	118"
76'	10' 10"	29' 1"	45' 5"	33' 9"	31' 7"	27' 10"	18' 3"	24' 9"	26' 2"	118"

**HORSEPOWER REQUIREMENTS**

	8"				10"			
	GAS HP	PTO HP	EMD HP	HYD	GAS HP	PTO HP	EMD HP	HYD
31	16	15	5	22 GPM @ 2200 PSI	18 - 20	30	7.5 - 10	22 GPM @ 2200 PSI
36	16 - 18	15	5 - 7.5	22 GPM @ 2200 PSI	22 - 25	35	10 - 15	22 GPM @ 2200 PSI
41	18 - 20	20	5 - 7.5	22 GPM @ 2200 PSI	22 - 25	40	10 - 15	22 GPM @ 2200 PSI
46	—	25	7.5	—	—	—	—	—
51	—	25	10 - 15	—	—	45	15 - 20	—
56	—	30	15	—	—	—	—	—
61	—	35	15 - 20	—	—	55	20	—
71	—	45	20	—	—	60	20 - 25	—
76	—	50	20 - 25	—	—	—	—	—

**Recommended Pulley Sizes:**

- Gas Motor Drives: 4.2" Double Groove Pulley
- Electric Motor Drives: 7.75"
- < 46' Double Groove, > 46' Triple Groove Pulley

**Recommended Engines (MD Only):**

**Gas Engines:**

Honda GX390  
 Honda GX630, GX660, GX690 (Side Muffler Mount Only\*)  
 Vanguard BigBlock V-Twin (25 - 31 HP)

**Electric Motors:**

Baldor/WEG 7.5 & 10 HP, 1800 RPM, 213T or 215T Frame  
 Baldor/WEG 15 & 20 HP, 1800 RPM, 254T or 256T Frame  
 US Motors 10 HP, 1800 RPM, 215T Frame

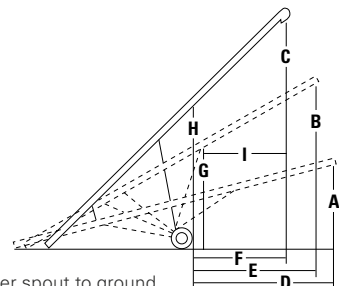

Heights measured from bottom of auger spout to ground.



## WRX8

	WRX8-31	WRX8-36	WRX8-41	WRX8-46	WRX8-51	WRX8-56	WRX8-61	WRX8-71	WRX8-76
TUBING GAUGE	14 GA								
TUBE CONNECTORS	Heavy-duty $\frac{3}{16}$ " Angle Flange								
MAIN FLIGHTING	7" OD x 10 GA Stretched + Welded								
INTAKE FLIGHTING	10 GA Welded with Wear Edge Technology™ Lower Pitch for High Capacity								
FLIGHTING SHAFT	High Strength 1.66" OD x 11 GA Tubing								
DRIVESHAFT	1- $\frac{1}{4}$ " OD x 11 GA Tubing								
DRIVESHAFT BEARINGS	1- $\frac{1}{4}$ " Oil Impregnated Hardwood Bearings								
TUBE TRUSSING	N/A			$\frac{5}{16}$ " Aircraft Cable					
TRACK	High Yield 11 GA Roll Formed								
TRACKSHOE	Single 2- $\frac{3}{4}$ " Steel Roller								
TRANSPORT/UNDERCARRIAGE	2- $\frac{1}{2}$ " x 14 GA A-Frame			3" OD x 11 GA A-Frame					
AXLE	2" x 11 GA Tubing			2- $\frac{1}{2}$ " x $\frac{1}{8}$ " Wall Sq. Tubing					
HUBS & WHEELS	4 Bolt Agricultural Type Hubs, 15" Wheel								
TIRES	15" Agricultural Tires								
LIFT CABLE	$\frac{1}{4}$ " Aircraft Type Galvanized Steel Cable								
TOP DRIVE	#80 Roller Chain & Hardened Steel Sprockets								
TOP DRIVE BEARINGS	1- $\frac{1}{4}$ " Pillow Block								
WINCH	Reduction Geared with Automatic brake								
GEARBOX	Formed Steel Gears with Tapered Roller Bearings								
CAPACITY - DRY WHEAT OR CORN, AUGER $\frac{1}{2}$ RAISED	Up to 3,000 BPH								

## WRX10

	WRX10-31	WRX10-36	WRX10-41	WRX10-51	WRX10-61	WRX10-71
TUBING GAUGE	12 GA					
TUBE CONNECTORS	Heavy-duty $\frac{3}{16}$ " Angle Flange					
MAIN FLIGHTING	9" OD x 7 GA Stretched + Welded					
INTAKE FLIGHTING	10 GA Welded with Wear Edge Technology™ Lower Pitch for High Capacity					
FLIGHTING SHAFT	High Strength 2" OD x 11 GA Tubing					
DRIVESHAFT	1- $\frac{1}{4}$ " OD x 11 GA Tubing					
DRIVESHAFT BEARINGS	1- $\frac{1}{4}$ " Oil Impregnated Hardwood Bearings					
TUBE TRUSSING	N/A			$\frac{5}{16}$ " Aircraft Cable		
TRACK	High Yield 11 GA Roll Formed					
TRACKSHOE	Single 2- $\frac{3}{4}$ " Steel Roller					
TRANSPORT/UNDERCARRIAGE	2- $\frac{1}{2}$ " x 14 GA A-Frame			3" OD x 11 GA A-Frame		
AXLE	2" x 11 GA Tubing			2- $\frac{1}{2}$ " x $\frac{1}{8}$ " Wall Sq. Tubing		
HUBS & WHEELS	4 Bolt Agricultural Type Hubs, 15" Wheel					
TIRES	15" Agricultural Tires					
LIFT CABLE	$\frac{1}{4}$ " Aircraft Type Galvanized Steel Cable					
TOP DRIVE	#80 Roller Chain & Hardened Steel Sprockets					
TOP DRIVE BEARINGS	1- $\frac{1}{4}$ " Pillow Block					
WINCH	Reduction Geared with Automatic brake					
GEARBOX	Formed Steel Gears with Tapered Roller Bearings					
CAPACITY - DRY WHEAT OR CORN, AUGER $\frac{1}{2}$ RAISED	Up to 4,800 BPH					

DISCLAIMER: The WRX series auger was proudly designed to handle dry, free-flowing grains up to a maximum density of 65 lb/bu (52 lb/cf). Any usage of this auger outside of this is not authorized by AGI Hutchinson

Part numbers are set up as Hutchinson part numbers. To order Mayrath, change the last "H" of the part number to an "M".

Part Number	Description	Weight (lbs)	Price
-------------	-------------	--------------	-------

### WRX BASIC AUGERS

*Shipped complete with undercarriage, enclosed driveline, intake with safety sheild, outlet spout, tow hitch, safety shields, winch, and tires with rims. NOTE: Must order a drive kit to complete auger.*

01-WRX0831SRH	8" X 31' Basic Auger (Painted Silver)	873	\$5,484.00
01-WRX0836SRH	8" X 36' Basic Auger (Painted Silver)	948	\$6,076.00
01-WRX0841SRH	8" X 41' Basic Auger (Painted Silver)	1047	\$6,696.00
01-WRX0846SRH	8" X 46' Basic Auger (Painted Silver)	1312	\$7,480.00
01-WRX0851SRH	8" X 51' Basic Auger (Painted Silver)	1392	\$8,284.00
01-WRX0851SRHS	8" X 51' Basic Auger with Corn Screen (Painted Silver)	1392	\$8,906.00
01-WRX0856SRH	8" X 56' Basic Auger (Painted Silver)	1599	\$10,132.00
01-WRX0856SRHS	8" X 56' Basic Auger with Corn Screen (Painted Silver)	1599	\$10,754.00
01-WRX0861SRH	8" X 61' Basic Auger (Painted Silver)	1654	\$11,776.00
01-WRX0861SRHS	8" X 61' Basic Auger with Corn Screen (Painted Silver)	1654	\$12,398.00
01-WRX0871SRH	8" X 71' Basic Auger (Painted Silver)	1868	\$12,886.00
01-WRX0871SRHS	8" X 71' Basic Auger with Corn Screen (Painted Silver)	1868	\$13,508.00
01-WRX0876SRH	8" X 76' Basic Auger (Painted Silver)	1918	\$13,579.00
01-WRX0876SRHS	8" X 76' Basic Auger with Corn Screen (Painted Silver)	1918	\$14,201.00
01-WRX1031SRH	10" X 31' Basic Auger (Painted Silver)	1146	\$7,637.00
01-WRX1036SRH	10" X 36' Basic Auger (Painted Silver)	1270	\$8,795.00
01-WRX1041SRH	10" X 41' Basic Auger (Painted Silver)	1406	\$10,029.00
01-WRX1051SRH	10" X 51' Basic Auger (Painted Silver)	1805	\$12,517.00
01-WRX1051SRHS	10" X 51' Basic Auger with Corn Screen (Painted Silver)	1805	\$13,205.00
01-WRX1061SRH	10" X 61' Basic Auger (Painted Silver)	2130	\$14,738.00
01-WRX1061SRHS	10" X 61' Basic Auger with Corn Screen (Painted Silver)	2130	\$15,426.00
01-WRX1071SRH	10" X 71' Basic Auger (Painted Silver)	2425	\$16,663.00
01-WRX1071SRHS	10" X 71' Basic Auger with Corn Screen (Painted Silver)	2425	\$17,351.00

### ELECTRIC MOTOR DRIVE KITS

*Shipped complete with tube mounted motor mount, belts, and pulley. LESS electric motor, switches, and motor pulley. Recommended pulley size: 7.75" for 1750 RPM motors.*

05-A418	WRX8/10-31/36/41 Electric Motor Drive Kit	100	\$1,671.00
05-A423	WRX8/10-46/51/56/61/71/76 Electric Motor Drive Kit	104	\$1,671.00

### HYDRAULIC DRIVE KITS

*Shipped complete with hydraulic motor mount and hydraulic hoses. Requires a minimum of 20 GPM at 2200 PSI.*

05-A428	WRX80-31/36/41 Hydraulic Drive Kit	100	\$3,064.00
05-A422	WRX10-31/36/41 Hydraulic Drive Kit	100	\$3,064.00

### PTO/SHAFT DRIVE KITS

*Shipped complete with shielded non-separable 60" PTO driveline and transport saddle.*

05-A429RD	WRX80-31 SD - PTO/Shaft Drive	151	\$2,052.00
05-A430RD	WRX80-36 SD - PTO/Shaft Drive	150	\$2,052.00
05-A431RD	WRX80-41 SD - PTO/Shaft Drive	151	\$2,052.00
05-A432RD	WRX80-46 SD - PTO/Shaft Drive	150	\$2,052.00
05-A433RD	WRX80-51 SD - PTO/Shaft Drive	152	\$2,052.00
05-A434RD	WRX80-56 SD - PTO/Shaft Drive	150	\$2,052.00
05-A435RD	WRX80-61 SD - PTO/Shaft Drive	172	\$2,052.00
05-A436RD	WRX80-71 SD - PTO/Shaft Drive	172	\$2,052.00
05-A444RD	WRX80-76 SD - PTO/Shaft Drive	189	\$2,052.00
05-A419RD	WRX10-31 SD - PTO/Shaft Drive	154	\$2,052.00
05-A420RD	WRX10-36 SD - PTO/Shaft Drive	152	\$2,052.00
05-A421RD	WRX10-41 SD - PTO/Shaft Drive	155	\$2,052.00
05-A424RD	WRX10-51 SD - PTO/Shaft Drive	155	\$2,052.00
05-A425RD	WRX10-61 SD - PTO/Shaft Drive	173	\$2,052.00
05-A426RD	WRX10-71 SD - PTO/Shaft Drive	176	\$2,052.00

Part numbers are set up as Hutchinson part numbers. To order Mayrath, change the last "H" of the part number to an "M".

Part Number	Description	Weight (lbs)	Price
<b>PTO/BELT DRIVE KITS</b>			
05-A472RD	WRX80-31 BD - PTO/Belt Drive	319	\$2,929.00
05-A460RD	WRX80-36 BD - PTO/Belt Drive	322	\$2,929.00
05-A461RD	WRX80-41 BD - PTO/Belt Drive	316	\$2,943.00
05-A462RD	WRX80-46 BD - PTO/Belt Drive	334	\$2,943.00
05-A463RD	WRX80/10-51 BD - PTO/Belt Drive	332	\$2,943.00
05-A473RD	WRX10-31 BD - PTO/Belt Drive	319	\$2,929.00
05-A464RD	WRX10-36 BD - PTO/Belt Drive	324	\$2,943.00
05-A465RD	WRX10-41 BD - PTO/Belt Drive	322	\$2,943.00
05-A463RD	WRX80/10-51 BD - PTO/Belt Drive	332	\$2,943.00

### PLAIN MOTOR DRIVE KITS

Shipped complete with motor mount, gearbox, belts, and pulleys. Recommended pulley size: 4.2" for gas engines, 7.75" for 1750 RPM electric motors.

05-A466	WRX8/10-31/41 Plain Motor Drive Kit	320	\$2,507.00
05-A467	WRX8/10-36 Plain Motor Drive Kit	321	\$2,507.00

### COMPLETE MOTOR DRIVE KITS

Shipped complete with motor mount, battery mount, gas tank mount, gas tank, gearbox, belts, and pulleys. Does not come with battery cables. Recommended pulley size: 4.2" for gas engines, 7.75" for 1750 RPM electric motors.

05-A470U	WRX8/10-31/41 Complete Motor Drive Kit	351	\$2,868.00
05-A471U	WRX8/10-36 Complete Motor Drive Kit	355	\$2,868.00

### 8" OPTIONS

05-A103	Standard Hopper	17	\$221.00
05-A114	WRX Swivel Arc Kit	72	\$629.00
05-A147	8" Corn Screen	20	\$622.00
05-A164	Poly Bucket Flex Spout, 36" - 5 Section, Fits 8/10" Augers	14	\$238.00
05-A250	8" Wheel Kit	69	\$855.00
05-A260	8" Bin Hopper	319	\$1,558.00
05-A285	WRX/STX <sup>2</sup> 8/10 Intake Hopper Tarp	6	\$296.00
05-A443	Speed Reducer Kit	156	\$1,352.00
05-A456	WRX Steel Caster Wheel Kit	53	\$1,195.00
05-A468	WRX8/10 Motor Drive Battery Kit	13	\$76.00
05-A469	WRX8/10 Motor Drive Fuel Tank Kit	30	\$293.00
05-A481	8" Enclosed Collapsible Hopper	261	\$1,508.00
05-A488	8"/10" Reduction Gearbox (2:1)		\$802.00
05-A489	8"/10" Reduction Gearbox (3:1)		\$802.00

More WRX options under "Optional Equipment"

### 10" OPTIONS

05-A104	Big Daddy Hopper	31	\$417.00
05-A114	WRX Swivel Arc Kit	72	\$629.00
05-A148	10" Corn Screen	27	\$688.00
05-A164	Poly Bucket Flex Spout, 36" - 5 Section, Fits 8/10" Augers	14	\$238.00
05-A197	Hydraulic Winch (Up to 10" x 71')	60	\$2,295.00
05-A249	10" Bin Hopper	334	\$1,655.00
05-A251	10" Wheel Kit	72	\$879.00
05-A282	No Snag Spout, 3 Section, Fits 10" Augers	8	\$310.00
05-A285	WRX/STX <sup>2</sup> 8/10 Intake Hopper Tarp	6	\$296.00
05-A442SR	WRX 10" X 3' Extension, Square Shaft	83	\$456.00
05-A443	Speed Reducer Kit	156	\$1,352.00
05-A456	WRX Steel Caster Wheel Kit	53	\$1,195.00
05-A468	WRX8/10 Motor Drive Battery Kit	13	\$76.00
05-A469	WRX8/10 Motor Drive Fuel Tank Kit	30	\$293.00

Part numbers are set up as Hutchinson part numbers. To order Mayrath, change the last "H" of the part number to an "M".

Part Number	Description	Weight (lbs)	Price
05-A482	10" Enclosed Collapsible Hopper	274	\$1,602.00
05-A488	8"/10" Reduction Gearbox (2:1)		\$802.00
05-A489	8"/10" Reduction Gearbox (3:1)		\$802.00

*More WRX options under "Optional Equipment"*

# STX<sup>2</sup> SERIES

TRUCK AUGERS



# Built for Durability, Longevity & Capacity

**STX<sup>2</sup> 8** 31' - 51' | up to 3,500 BPH

**STX<sup>2</sup> 10** 31' - 51' | up to 5,500 BPH

AGI Hutchinson's redesigned truck auger has been engineered to withstand the demands of farming today. The STX<sup>2</sup> was built for durability, longevity and capacity. With the STX<sup>2</sup>, you'll get the job done fast.

## Built for Durability

The STX<sup>2</sup> features 12-gauge tubing on 10" models, a heavy-duty motor mount designed to handle high horsepower, heavy auger engines, giving you the flexibility to use the engine you want.

Like all AGI Hutchinson augers, the flighting includes Wear Edge Technology™, which provides an extra layer of steel welded to the edge at critical wear points to extend the life of your flighting.

AGI Hutchinson's STX<sup>2</sup> Auger features a completely enclosed driveline guard providing a cleaner, sleeker look while protecting your auger from the elements. To protect the auger's appearance and repel rust, AGI Hutchinson also uses powder coat paint for a long lasting durable finish.

Heavy-duty hardened steel sprockets and high-speed roller chain are sized to match auger length and diameter, to help your auger perform at its best. A lubricated upper drive extends the life of sprockets and drive chain.

The 10" models use square, one-bolt flight connections to ensure the flighting maintains proper alignment for smooth operation.

## Designed for High Capacity

The STX<sup>2</sup> uses double banded belts that are molded together as one to transfer maximum power from the engine to the gearboxes to maintain consistent speed when the auger is running. To ensure optimal performance is achieved with longer units, the 10" in 46' and 51' lengths use triple banded belts.

## Developed for Ease-of-Use

AGI Hutchinson's STX<sup>2</sup> is designed with end users in mind. The self-leveling motor maintains proper tension at all heights, so there is no need to reset the belt tension once the auger is raised into position to provide better traction. Less slippage means you can get the job done faster. The electric clutch with remote allows you to start and stop the auger without shutting down the gas engine drives.

AGI Hutchinson has redesigned their mover kit to make set up as easy as possible. A breeze to move around the yard thanks to it's joystick steering, the Self-Propelled (SP) kit also automatically adjusts the intake height when auger discharge is raised or lowered.

## Low Maintenance

The drive shaft bearings are constructed of durable, oil impregnated hardwood for long, quiet operation and can be easily replaced if needed without disassembling the drive shaft. The bearing brackets are factory jig welded to ensure precise alignment. The chain tensioner on the top drive can be easily adjusted and provides consistent chain drive tension, helping to prolong the life of the chain.

## Convenient – Easy to Transport

The STX<sup>2</sup> features a quick detach tow hitch that can be stored on the auger so it's ready to go when you need it. Moving around the yard is even easier with the optional Self-Propelled mover kit, or standard mover kit.

## Warranty

AGI Hutchinson is committed to providing quality products. To ensure your STX<sup>2</sup> is ready when you need it, AGI Hutchinson offers a two year limited warranty.



Geometry

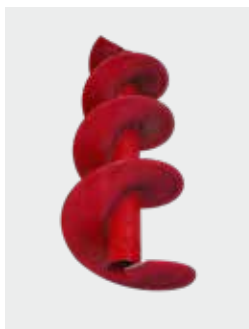

Wear Edge Technology™



Square One-Bolt Connection



Banded Belts



Steel Sprockets

## OPTIONS & ACCESSORIES



### Self-Propelled Heavy-Duty Mover

This Self-Propelled (SP) heavy-duty mover kit features all-wheel drive, hydraulic steering, and rugged all-terrain tires capable of handling tough terrain and yards. This narrow, more compact design allows better access to larger diameter hopper bins and offers drive controls situated closer to the motor to further increase reach under large hoppers. This new mover kit allows for a much sharper turning radius for quicker and easier repositioning. Hydraulic steering comes standard.



### Electric Clutch with Remote Control

The electric clutch with remote control starts and stops the auger without shutting down the gas engine drives and is easy to install.



### Reversing Gearbox

The reversing gearbox allows the auger to be reversed at all angles and includes the linkage and lockout for easy clean-out.

### Steel Hydraulic Lines

Steel hydraulic lines with ORB fittings on the cylinder create a cleaner look and reduces risk of leakage.



### Poly Hoppers

Poly hoppers are durable and flexible providing easy grain handling with minimum spillage. Two sizes available: regular poly hopper for 8" augers and a larger "V" hoppers for 10" augers.

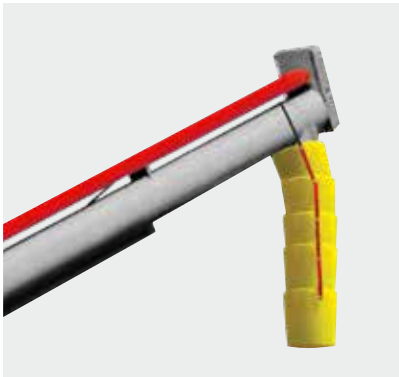

### Poly Flex Spout

The durable poly flex spout features a five-section flex bucket designed to withstand the elements. Poly spouts help direct grain and prevent spillage so nothing is wasted.

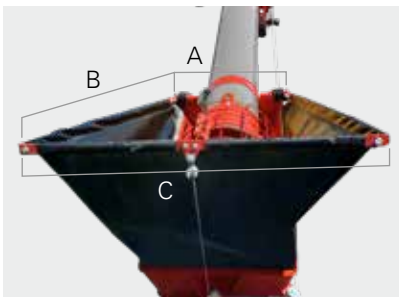

Bin Hopper Dimensions: 36" Long x 36" Wide

### Steel Intake Hopper

The steel intake hopper is self-leveling and has a tapered transition that works with the flighting to direct the flow of grain from the hopper into the auger. The steel intake hopper has a removable access plate for easy cleanout and the flighting features Wear Edge Technology™. The steel intake hopper comes complete with a tow hitch. An optional wheel kit is available and allows the height to be adjusted for positioning.



### LED Working Lights

LED working lights are mounted to the auger to provide extra lighting in low-light situations, allowing you to work longer when needed.



### Enclosed Collapsible Hopper

The new enclosed collapsible hopper is a cost effective option that delivers ease of use and maximized efficiency. The hopper mounts over your existing intake cage and releases with the removal of two hitch pins. A removable access door makes for easy cleanout. Comes complete with tow hitch.

### Enclosed Collapsible Hopper Specifications

	8"	10"
<b>A</b>	16"	18.5"
<b>B</b>	36.5"	36.5"
<b>C</b>	33"	35.5"

	8"	10"
<b>COLLAPSED HEIGHT</b>	8"	9.5"
<b>TOTAL HEIGHT</b>	26.5"	27.5"



**STX<sup>2</sup>**

	8-31	8-36	8-41	8-46	8-51	10-31	10-36	10-41	10-46	10-51
TUBING GAUGE	14 GA					12 GA				
TUBE CONNECTORS	Heavy-duty 3/16" Angle Flange									
MAIN FLIGHTING	7" OD x 10 GA Stretched + Welded					9" OD x 7 GA Stretched + Welded				
INTAKE FLIGHTING	10 GA Welded with Wear Edge Technology™ Lower Pitch for High Capacity									
FLIGHTING SHAFT	High Strength 1.66" OD x 11 GA Tubing					High Strength 2" OD x 11 GA Tubing				
DRIVE SHAFT	1 1/4" OD x 11 GA Tubing									
DRIVE SHAFT BEARINGS	1 1/4" Oil Impregnated Hardwood Bearings									
TUBE TRUSSING	N/A	N/A	N/A	5/16" Aircraft Cable	5/16" Aircraft Galv. Steel Cable	N/A	N/A	N/A	N/A	5/16" Aircraft Cable
TRACK	High Yield 11 GA Roll Formed									
TRACKSHOE	2 3/4" Steel Roller									
UNDERCARRIAGE	2 1/2" Square Tubing (Upper), 3" Square Tubing (Lower)			3" Square Tubing		2 1/2" Square Tubing (Upper), 3" Square Tubing (Lower)			3" Square Tubing	
AXLE	2 1/2" Square Tubing									
HUBS & WHEELS	4 Bolt Agricultural Type Hubs, 15" Wheel									
TIRES	15" Agricultural Tires									
LIFT CABLE	1/4" Aircraft Type Galvanized Steel Cable									
TOP DRIVE	#80 Roller Chain & Hardened Steel Sprockets									
TOP DRIVE BEARINGS	1 1/4" Cast Flange									
WINCH	Reduction Geared with Automotive Brake									
GEARBOX	Formed Steel Gears with Tapered Roller Bearings									
WHEEL TREAD	96"									
GAS HORSEPOWER	16	16 - 18	18 - 20	22 - 25	25 - 30	25	25 - 30	30 - 35	35 - 38	35 - 38
ELECTRIC HORSEPOWER	5	5 - 7 1/2	5 - 7 1/2	7 1/2	10 - 15	10 - 15	15	15	15	15

**DISCLAIMER:** The STX2 series auger was proudly designed to handle dry, free-flowing grains up to a maximum density of 65 lb/bu (52 lb/cf). Any usage of this auger outside of this is not authorized by AGI

**HEIGHT | REACH | WHEEL | SPECIFICATIONS**

	A	B	C	D	E	F	G
<b>8-31</b>	8' 6"	13' 6"	18' 10"	12' 6"	12' 2"	11' 7"	8' 5"
<b>8-36</b>	9'	15' 8"	22' 1"	14' 6"	14' 1"	13' 2"	10'
<b>8-41</b>	8' 4"	16' 4"	24' 6"	16' 9"	16' 5"	15' 9"	12' 1"
<b>8-46</b>	10'	17'	26' 1"	18' 6"	18' 4"	17' 3"	14' 10"
<b>8-51</b>	10' 6"	19' 9"	29'	19' 3"	18' 7"	17' 7"	16' 1"
<b>10-31</b>	8' 6"	13' 6"	18' 10"	12' 6"	12' 2"	11' 7"	8' 7"
<b>10-36</b>	9'	15' 8"	22' 1"	14' 6"	14' 1"	13' 2"	10' 2"
<b>10-41</b>	8' 4"	16' 4"	24' 6"	16' 9"	16' 5"	15' 9"	12' 3"
<b>10-46</b>	10'	17'	26' 1"	18' 6"	18' 4"	17' 3"	14' 11"
<b>10-51</b>	10' 6"	19' 9"	29'	19' 3"	18' 7"	17' 7"	16' 3"

Heights measured from bottom of auger spout to ground.

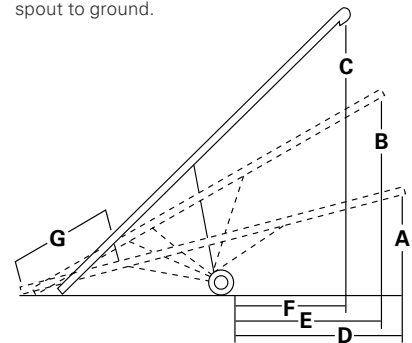

Part numbers are set up as Hutchinson part numbers. To order Mayrath, change the last "H" of the part number to an "M".

Part Number	Description	Weight (lbs)	Price
<b>STX<sup>2</sup> 8-31 AUGER</b>			
01-STX20831SRH	Basic Auger (Painted Silver)	1475	\$8,315.00
01-STX20831SRSPH	Auger with Self Propelled Kit Only (Painted Silver)	1878	\$14,447.00
01-STX20831SRSPCBH	Complete Bundle with Self Propelled Kit	2021	\$17,981.00
<b>A complete bundle includes: 1-1/8" Clutch Kit, Battery Mount, Gas Tank, Reversing Gearbox, Light Kit and Battery Cables</b>			

<b>STX<sup>2</sup> 8-36 AUGER</b>			
01-STX20836SRH	Basic Auger (Painted Silver)	1612	\$8,894.00
01-STX20836SRSPH	Auger with Self Propelled Kit Only (Painted Silver)	2030	\$15,174.00
01-STX20836SRSPHH	Auger with Heavy Duty Self Propelled Kit Only	2401	\$19,851.00
01-STX20836SRSPCBH	Complete Bundle with Self Propelled Kit	2158	\$18,706.00
01-STX20836SRSPHCBH	Complete Bundle with Heavy Duty Self Propelled Kit	2527	\$23,387.00
<b>A complete bundle includes: 1-1/8" Clutch Kit, Battery Mount, Gas Tank, Reversing Gearbox, Light Kit and Battery Cables</b>			

<b>STX<sup>2</sup> 8-41 AUGER</b>			
01-STX20841SRH	Basic Auger (Painted Silver)	1716	\$9,435.00
01-STX20841SRSPH	Auger with Self Propelled Kit Only (Painted Silver)	2148	\$16,133.00
01-STX20841SRSPHH	Auger with Heavy Duty Self Propelled Kit Only	2518	\$20,939.00
01-STX20841SRSPCBH	Complete Bundle with Self Propelled Kit	2276	\$19,668.00
01-STX20841SRSPHCBH	Complete Bundle with Heavy Duty Self Propelled Kit	2644	\$24,474.00
<b>A complete bundle includes: 1-1/8" Clutch Kit, Battery Mount, Gas Tank, Reversing Gearbox, Light Kit and Battery Cables</b>			

<b>STX<sup>2</sup> 8-46 AUGER</b>			
01-STX20846SRH	Basic Auger (Painted Silver)	1889	\$10,196.00
01-STX20846SRSPH	Auger with Self Propelled Kit Only (Painted Silver)	2272	\$17,035.00
01-STX20846SRSPHH	Auger with Heavy Duty Self Propelled Kit Only	2635	\$21,954.00
01-STX20846SRSPCBH	Complete Bundle with Self Propelled Kit	2489	\$20,564.00
01-STX20846SRSPHCBH	Complete Bundle with Heavy Duty Self Propelled Kit	2761	\$25,490.00
<b>A complete bundle includes: 1-1/8" Clutch Kit, Battery Mount, Gas Tank, Reversing Gearbox, Light Kit and Battery Cables</b>			

<b>STX<sup>2</sup> 8-51 AUGER</b>			
01-STX20851SRH	Basic Auger (Painted Silver)	2025	\$10,972.00
01-STX20851SRSPH	Auger with Self Propelled Kit Only (Painted Silver)	2486	\$17,275.00
01-STX20851SRSPHH	Auger with Heavy Duty Self Propelled Kit Only	2765	\$22,226.00
01-STX20851SRSPCBH	Complete Bundle with Self Propelled Kit	2633	\$20,807.00
01-STX20851SRSPHCBH	Complete Bundle with Heavy Duty Self Propelled Kit	2896	\$25,762.00
<b>A complete bundle includes: 1-1/8" Clutch Kit, Battery Mount, Gas Tank, Reversing Gearbox, Light Kit and Battery Cables</b>			

<b>OPTIONS</b>			
10-28109	Battery Cables (Set of Two)	2	\$104.00
05-A103	Standard Hopper	17	\$221.00
05-A147	8" Corn Screen	20	\$622.00
05-A164	Poly Bucket Flex Spout, 36" - 5 Section, Fits 8/10" Augers	14	\$238.00
05-A224	Electric Clutch Kit 1-1/8" Shaft Size	19	\$1,900.00
05-A225	Electric Clutch Kit 1" Shaft Size	19	\$1,900.00
05-A250	8" Wheel Kit	69	\$855.00
05-A260	8" Bin Hopper	319	\$1,558.00
05-A285	WRX/STX <sup>2</sup> 8/10 Intake Hopper Tarp	6	\$296.00
05-A391	STX <sup>2</sup> 36/41/46/51 Reversible Gearbox Kit	63	\$1,345.00
05-A414	Electric Clutch Kit 1-1/8" Triple Grove (2019)	35	\$3,895.00

Part numbers are set up as Hutchinson part numbers. To order Mayrath, change the last "H" of the part number to an "M".

Part Number	Description	Weight (lbs)	Price
05-A415	STX <sup>2</sup> Gas Tank Package, 42L with Hose (2019)	42	\$286.00
05-A437	STX <sup>2</sup> 8/1036 Enclosed Belt Guard Kit	19	\$150.00
05-A438	STX <sup>2</sup> 8/1041 Enclosed Belt Guard Kit	23	\$165.00
05-A439	STX <sup>2</sup> 8/1046 Enclosed Belt Guard Kit	26	\$188.00
05-A440	STX <sup>2</sup> 8/1051 Enclosed Belt Guard Kit	27	\$223.00
05-A481	8" Enclosed Collapsible Hopper	261	\$1,508.00
05-A519	STX46/51 LED Light Kit	6	\$735.00
05-A521	STX36/41 LED Light Kit	6	\$735.00

### STX<sup>2</sup> 10-31 AUGER

01-STX21031SRH	Basic Auger (Painted Silver)	1714	\$10,417.00
01-STX21031SRSPH	Auger with Self Propelled Kit Only (Painted Silver)	2126	\$16,369.00
01-STX21031SRSPCBH	Complete Bundle with Self Propelled Kit	2249	\$19,899.00

**A complete bundle includes: 1-1/8" Clutch Kit, Battery Mount, Gas Tank, Reversing Gearbox, Light Kit and Battery Cables**

### STX<sup>2</sup> 10-36 AUGER

01-STX21036SRH	Basic Auger (Painted Silver)	1867	\$11,547.00
01-STX21036SRSPH	Auger with Self Propelled Kit Only (Painted Silver)	2258	\$16,965.00
01-STX21036SRSPHH	Auger with Heavy Duty Self Propelled Kit Only	2650	\$21,884.00
01-STX21036SRSPCBH	Complete Bundle with Self Propelled Kit	2416	\$20,501.00
01-STX21036SRSPHCBH	Complete Bundle with Heavy Duty Self Propelled Kit	2780	\$25,416.00

**A complete bundle includes: 1-1/8" Clutch Kit, Battery Mount, Gas Tank, Reversing Gearbox, Light Kit and Battery Cables**

### STX<sup>2</sup> 10-41 AUGER

01-STX21041SRH	Basic Auger (Painted Silver)	2004	\$12,659.00
01-STX21041SRSPH	Auger with Self Propelled Kit Only (Painted Silver)	2440	\$17,507.00
01-STX21041SRSPHH	Auger with Heavy Duty Self Propelled Kit Only	2799	\$22,495.00
01-STX21041SRSPCBH	Complete Bundle with Self Propelled Kit	2568	\$21,039.00
01-STX21041SRSPHCBH	Complete Bundle with Heavy Duty Self Propelled Kit	2929	\$26,029.00

**A complete bundle includes: 1-1/8" Clutch Kit, Battery Mount, Gas Tank, Reversing Gearbox, Light Kit and Battery Cables**

### STX<sup>2</sup> 10-46 AUGER

01-STX21046SRH	Basic Auger (Painted Silver)	2195	\$14,400.00
01-STX21046SRSPH	Auger with Self Propelled Kit Only (Painted Silver)	2569	\$18,468.00
01-STX21046SRSPHH	Auger with Heavy Duty Self Propelled Kit Only	2926	\$23,668.00
01-STX21046SRSPCBH	Complete Bundle with Self Propelled Kit	2804	\$23,716.00
01-STX21046SRSPHCBH	Complete Bundle with Heavy Duty Self Propelled Kit	3055	\$28,915.00

**A complete bundle includes: 1-1/8" Clutch Kit, Battery Mount, Gas Tank, Reversing Gearbox, Light Kit and Battery Cables**

### STX<sup>2</sup> 10-51 AUGER

01-STX21051SRH	Basic Auger (Painted Silver)	2408	\$15,180.00
01-STX21051SRSPH	Auger with Self Propelled Kit Only (Painted Silver)	2779	\$19,554.00
01-STX21051SRSPHH	Auger with Heavy Duty Self Propelled Kit Only	3132	\$24,813.00
01-STX21051SRSPCBH	Complete Bundle with Self Propelled Kit	3028	\$24,801.00
01-STX21051SRSPHCBH	Complete Bundle with Heavy Duty Self Propelled Kit	3261	\$30,058.00

**A complete bundle includes: 1-1/8" Clutch Kit, Battery Mount, Gas Tank, Reversing Gearbox, Light Kit and Battery Cables**

### OPTIONS

10-28109	Battery Cables (Set of Two)	2	\$104.00
05-A104	Big Daddy Hopper	31	\$417.00

Part numbers are set up as Hutchinson part numbers. To order Mayrath, change the last "H" of the part number to an "M".

Part Number	Description	Weight (lbs)	Price
05-A147	8" Corn Screen	20	\$622.00
05-A164	Poly Bucket Flex Spout, 36" - 5 Section, Fits 8/10" Augers	14	\$238.00
05-A224	Electric Clutch Kit 1-1/8" Shaft Size	19	\$1,900.00
05-A225	Electric Clutch Kit 1" Shaft Size	19	\$1,900.00
05-A249	10" Bin Hopper	334	\$1,655.00
05-A251	10" Wheel Kit	72	\$879.00
05-A282	No Snag Spout, 3 Section, Fits 10" Augers	8	\$310.00
05-A285	WRX/STX <sup>2</sup> 8/10 Intake Hopper Tarp	6	\$296.00
05-A391	STX <sup>2</sup> 36/41/46/51 Reversible Gearbox Kit	63	\$1,345.00
05-A414	Electric Clutch Kit 1-1/8" Triple Grove (2019)	35	\$3,895.00
05-A415	STX <sup>2</sup> Gas Tank Package, 42L with Hose (2019)	42	\$286.00
05-A437	STX <sup>2</sup> 8/1036 Enclosed Belt Guard Kit	19	\$150.00
05-A438	STX <sup>2</sup> 8/1041 Enclosed Belt Guard Kit	23	\$165.00
05-A439	STX <sup>2</sup> 8/1046 Enclosed Belt Guard Kit	26	\$188.00
05-A440	STX <sup>2</sup> 8/1051 Enclosed Belt Guard Kit	27	\$223.00
05-A482	10" Enclosed Collapsible Hopper	274	\$1,602.00
05-A519	STX46/51 LED Light Kit	6	\$735.00
05-A520RD	Throttle Controls Kit	12	\$523.00
05-A521	STX36/41 LED Light Kit	6	\$735.00

# UTX

U-TROUGH AUGER



# High Powered, High Capacity

AGI Hutchinson is dedicated to bringing the highest level of manufacturing quality and expertise to the agriculture industry. Through this commitment to innovation, AGI Hutchinson introduces the UTX U-Trough Auger.

The UTX Auger brings together innovations like Wear Edge Technology™ to extend the life of the flighting and powder coat paint to protect against and repel rust. AGI Hutchinson's UTX Auger features a completely enclosed driveline guard providing a cleaner, sleeker look while protecting your auger from the elements. Steel hydraulic lines with ORB fittings have been added to the new Self-Propelled Mover Kit to create a cleaner look while reducing the chance of leakage. We know farmers are looking for labor-saving, cost-effective upgrades to help make their work easier. AGI Hutchinson recognizes these needs and has added features like a removable tow bar to make connecting and detaching from the hitch easier than ever and a hydraulic winch to raise and lower the auger with ease and precision. AGI Hutchinson has also added an easily adjustable chain tensioner to help maintain the consistent chain drive tension. The top drive comes sealed with a durable cover and inside you'll find grease-lubricated, forged steel sprockets and a heavy-duty chain, designed to match your auger's capacity. For long, quiet operation, the driveshaft and bearings are constructed of durable oil impregnated hardwood and can be easily replaced without disassembling the driveshaft.

To further improve performance, AGI Hutchinson uses square one-bolt flight connections providing positive torque transfer. All UTX models come standard with triple banded belts to better maintain speed by providing improved tension with less slippage. AGI Hutchinson's UTX Truck Auger is a high performance, high capacity auger that's ready to help make your job easier and faster.



## Reversing Gearbox

Comes with shifting linkage and lockout, allowing the operator to safely reverse the auger at all angles.



## Self-Propelled Heavy-Duty Mover

Complete with all-wheel drive, standard hydraulic steering, and rugged all-terrain tires capable of handling tough terrain, this compact mover kit gives better access to large diameter hopper bins and a sharper turning radius.

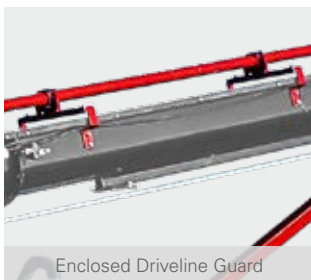

Enclosed Driveline Guard

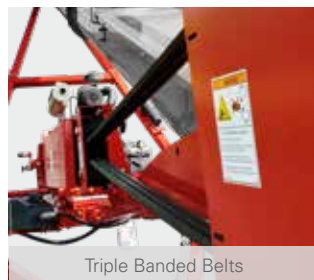

Triple Banded Belts



Adjustable Chain Tensioner



Steel Hydraulic Lines



### Collapsing Spring Loaded Hopper Extension

Quickly and easily fit under your lowest and hardest to reach bin unloads and hopper bins with this hopper extension.



### Gas Motor

Choose either a Vanguard or Kohler gas motor, with a large 44-liter gas tank that lets you work as long as you need to.

Heights measured from bottom of auger spout to ground.

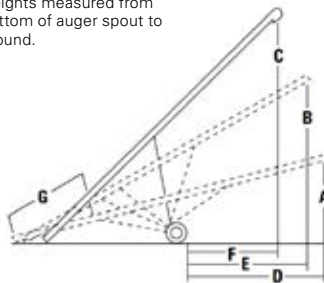

A	9' 2"
B	13' 9"
C	18' 4"
D	14' 10"
E	15'
F	14' 7"
G	11'



### Work Lights

LED work lights provide enhanced lighting conditions when the sun has gone down.



### Triple-Groove Electric Clutch

Start and stop the auger without shutting down the gas engine drives.

### SPECIFICATIONS

TROUGH GAUGE	12 GA
TROUGH CONNECTORS	¼" Flange
MAIN FLIGHTING	10" OD x 7 GA stretched + welded
INTAKE FLIGHTING	10" OD x 7 GA welded with Wear Edge Technology™
FLIGHTING SHAFT	2" OD x 0.120" Wall tubing
DRIVESHAFT	1 ½" OD x 10 GA tubing
DRIVESHAFT BEARINGS	1 ½" Oil impregnated hardwood bearings
TRACK	High yield 11 GA roll formed
TRACK SHOE	2 ¾" Steel roller
UNDERCARRIAGE	3" Square tubing
AXLES	2 ½" Square tubing
HUB & WHEELS	4 Bolt agricultural type hubs, 15" wheel
LIFT CABLE	¼" Aircraft type galvanized steel cable
TIRES	15" Agricultural tires
BELT SIZE	3B270
TOP DRIVE	#80 Roller chain & hardened steel sprockets
TOP DRIVE BEARINGS	1 ¼" Pillow block
WINCH	Reduction gear with automotive brake
GEARBOX	Formed steel gears with tapered roller bearings
WHEEL TREAD	96"
GAS HORSEPOWER	37 - 38
CAPACITY	7,000 - 9,000 BPH

**DISCLAIMER:** The UTX series auger was proudly designed to handle dry, free-flowing grains up to a maximum density of 65 lb/bu (52 lb/cf). Any usage of this auger outside of this is not authorized by AGI

	DISCHARGE CLEARANCE DIMENSIONS	TRANSPORT DIMENSIONS
MIN	9' 6"	LENGTH 45' 6"
MAX	18' 1"	WIDTH 8'
HEIGHT	10' 6"	HEIGHT 10' 6"

WEIGHT		HOPPER DIMENSIONS	
HITCH WEIGHT (W/ ENGINE)	472 LBS	A - HOPPER LENGTH	37 ½"
TOTAL WEIGHT (W/ ENGINE)	3,058 LBS	B - HOPPER WIDTH	29 ¾"
HEIGHT	10' 6"	C - CANVAS OPENING LENGTH	34 ⅛"
		D - CANVAS OPENING WIDTH	37 ¾"
		E - COLLAPSED HEIGHT	15 ⅝"

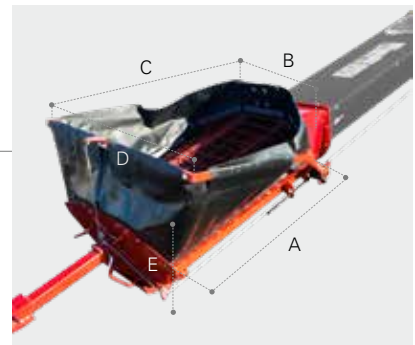

Part numbers are set up as Hutchinson part numbers. To order Mayrath, change the last "H" of the part number to an "M".

Part Number	Description	Weight (lbs)	Price
<b>UTX 44 AUGER</b>			
01-UTX44SPHCBVH	U-Trough Auger with Vanguard 40 HP EFI Motor	3572	\$45,035.00



# WR+W

## HEIGHT | REACH | WHEEL | SPECIFICATIONS

WR	A HEIGHT LOWERED	B HEIGHT HALFWAY	C HEIGHT RAISED	D REACH LOWERED	E REACH HALFWAY	F REACH RAISED	G HEIGHT AT LIFTARMS	H HEIGHT AT WHEELS	I REACH TO LIFTARMS	WHEEL TREAD
26'	6' 5"	12' 8"	17' 11"	10' 9"	9' 5"	7' 3"	7' 9"	11' 4"	6' 10"	68"
31'	7' 8"	15' 1"	21' 6"	13' 9"	12' 0"	9' 3"	8' 10"	12' 10"	7' 8"	70"
36'	9' 0"	17' 4"	24' 10"	16' 3"	14' 3"	11' 2"	10' 0"	14' 4"	8' 11"	82"
41'	9' 7"	20' 2"	28' 7"	18' 8"	16' 4"	12' 8"	11' 6"	16' 4"	10' 2"	88"
51'	11' 11"	25' 0"	35' 0"	23' 1"	20' 2"	15' 10"	14' 2"	19' 11"	12' 10"	94"
61'	11' 8"	28' 4"	41' 0"	27' 4"	24' 4"	19' 0"	17' 2"	24' 3"	16' 2"	112"
W										
31'	7' 7"	13' 9"	19' 3"	13'	11' 9"	9' 8"	9'	12' 5"	8'	106"
36'	7' 10"	15' 4"	22' 1"	15'	14' 2"	12' 11"	9' 6"	12' 10"	11' 1"	106"
41'	10' 0"	19' 9"	28' 3"	16' 5"	14' 5"	11' 3"	—	—	—	94"
51'	10' 9"	21' 10"	35' 5"	22' 4"	20' 2"	15' 3"	—	—	—	112"
61'	11' 7"	25' 8"	41' 1"	27' 5"	24' 10"	20' 0"	—	—	—	118"
71'	12' 11"	30' 10"	47' 0"	32' 3"	29' 5"	23' 1"	—	—	—	124"

### Recommended Pulley Sizes:

- Gas Motor Drives: 4.2" Double Groove Pulley
- Electric Motor Drives: 7.75" (WR 6), 4" - 4.3" (W 13)  
 < 41' Double Groove, > 41' Triple Groove Pulley

## HORSEPOWER REQUIREMENTS

	6"			13"	
	GAS HP	PTO HP	ELEC. HP	PTO HP	ELEC. HP
26'	10	—	3	—	—
31'	10	—	3	40	20
36'	12	—	3	40 - 50	20 - 25
41'	12	—	3	50	25
51'	—	20	5	70	—
61'	—	25	7.5	80	—
71'	—	—	—	90	—

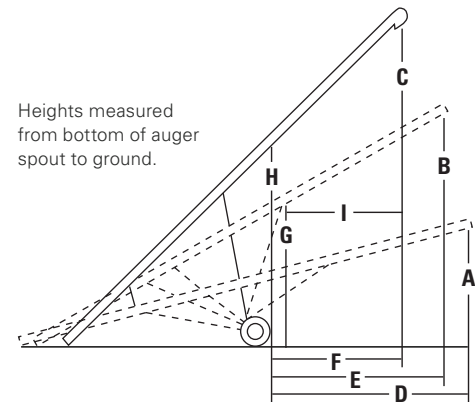

**Disclaimer:** The WR+W series auger was proudly designed to handle dry, free-flowing grains up to a maximum density of 65 lb/bu (52 lb/cf). Any usage of this auger outside of this is not authorized by AGI Westfield

Part numbers are set up as Hutchinson part numbers. To order Mayrath, change the last "H" of the part number to an "M".

Part Number	Description	Weight (lbs)	Price
<b>WR 6 x 26 AUGER</b>			
01-0626SRMDH	WR60 - 26 Motor Drive	605	\$4,995.00
01-0626SREMDH	WR60 - 26 Electric Motor Drive	545	\$5,367.00

<b>WR 6 x 31 AUGER</b>			
01-0631SRMDH	WR60 - 31 Motor Drive	660	\$5,514.00
01-0631SREMDH	WR60 - 31 Electric Motor Drive	660	\$5,891.00
01-0631SRSDH	WR60 - 31 Shaft Drive	660	\$6,811.00

<b>WR 6 x 36 AUGER</b>			
01-0636SRMDH	WR60 - 36 Motor Drive	735	\$6,103.00
01-0636SREMDH	WR60 - 36 Electric Motor Drive	735	\$6,522.00
01-0636SRBDH	WR60 - 36 Belt Drive	825	\$7,609.00
01-0636SRSDH	WR60 - 36 Shaft Drive	735	\$7,206.00

<b>WR 6 x 41 AUGER</b>			
01-0641SRMDH	WR60 - 41 Motor Drive	820	\$6,550.00
01-0641SREMDH	WR60 - 41 Electric Motor Drive	815	\$6,896.00
01-0641SRBDH	WR60 - 41 Belt Drive	905	\$8,057.00
01-0641SRSDH	WR60 - 41 Shaft Drive	765	\$7,690.00

<b>WR 6 x 51 AUGER</b>			
01-0651SREMDH	WR60 - 51 Electric Motor Drive	1000	\$8,745.00
01-0651SRSDH	WR60 - 51 Shaft Drive	1015	\$9,608.00

<b>WR 6 x 61 AUGER</b>			
01-0661SREMDH	WR60 - 61 Electric Motor Drive	1400	\$11,406.00
01-0661SRSDH	WR60 - 61 Shaft Drive	1410	\$11,865.00

<b>OPTIONS</b>			
05-A103	Standard Hopper	17	\$221.00
05-A161	Shielded PTO Driveline, 48" Closed	28	\$698.00
05-A162	Shielded PTO Driveline, 60" Closed	32	\$741.00
05-A163	Poly Bucket Flex Spout, 36" - 5 section, Fits 6/7" Augers	10	\$221.00

<b>W 13 x 31 AUGER</b>			
01-1331SREMDH	W130 - 31 Electric Motor Drive	1787	\$15,874.00
01-1331SRSDH	W130 - 31 PTO Shaft Drive	1796	\$16,260.00

<b>W 13 x 36 AUGER</b>			
01-1336SREMDH	W130 - 36 Electric Motor Drive	1920	\$16,797.00
01-1336SRSDH	W130 - 36 PTO Shaft Drive	1951	\$17,181.00

<b>W 13 x 41 AUGER</b>			
01-1341SREMDH	W130 - 41 Electric Motor Drive	2210	\$17,721.00
01-1341SRSDH	W130 - 41 PTO Shaft Drive	2160	\$18,108.00

<b>W 13 x 51 AUGER</b>			
01-1351SRSDH	W130 - 51 PTO Shaft Drive	2975	\$29,257.00

<b>W 13 x 61 AUGER</b>			
01-1361SRSDH	W130 - 61 PTO Shaft Drive	3440	\$32,565.00

Part numbers are set up as Hutchinson part numbers. To order Mayrath, change the last "H" of the part number to an "M".

Part Number	Description	Weight (lbs)	Price
<b>W 13 x 71 AUGER</b>			
01-1371SRSDH	W130 - 71 PTO Shaft Drive	3935	\$36,328.00

**OPTIONS**

05-A185	13" Corn Screen	33	\$1,007.00
05-A254	13" Bin Hopper	488	\$1,925.00
05-A255	13" Wheel Kit	78	\$921.00
05-A286	WRX13 Intake Hopper Tarp	7	\$329.00
05-A483	13" Enclosed Collapsible Hopper	293	\$1,865.00

# AUGER TOOLS



# Auger Tools

AGI offers a range of tools for your operation to assist with the maintenance of your auger. Contact us today to place an order!

## Reducer/Reverser Lifter Kits

B001 - 16"

B002 - 13"

This tool will help you quickly lift our 13" or 16" reducer/reverser gearboxes. Hooks onto the cooling fins on the gearbox and provides a simple loop at the top for hoisting.

(1 pcs)

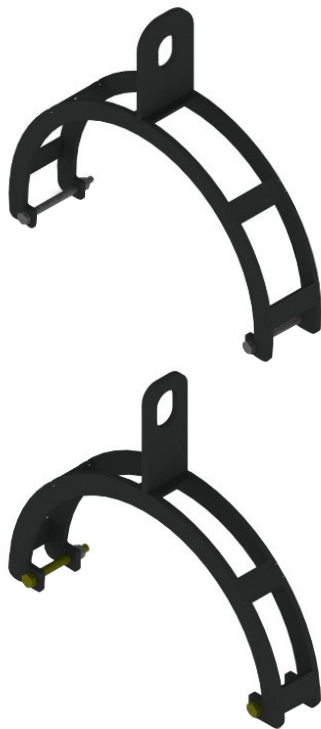

## Gooseneck Hitch Kit

B003

Make towing large augers easier. Simply replace the short tow bar on any 13" or 16" auger and you can tow the auger with better weight distribution on your truck. (1 pcs)



## 5<sup>th</sup> Wheel Hitch Kit

B004

Tow your auger with your 5th wheel truck with ease. Simply replace the short tow bar on any 13" or 16" auger and you can tow the auger with your 5th wheel truck. Allows for better weight distribution on your truck. (1 pcs)



## Boot Lifter Kit

B005

This boot lifter works on your 13" or 16" boots. The adjustable winch bracket makes it easy to balance the boot for easy placement. (1 pcs)



## Reducer/Reverser Puller Kit

B006

This puller fits perfectly over your 13" or 16" gearbox making it easy to remove from the auger. This kit comes with an extra puller rod.



## Sawhorse Kit

B007

A trick to easy assembling. The scratch-free kit is a perfect combination with the tube cradle kits. The tube cradle kits sit nicely on these sawhorses providing a sturdy foundation.

(1 pcs)



## Tube Cradle Kit

B008

Available in all auger tube sizes, the tube cradle kit perfectly cradles your auger. Its rubber padded interior keeps your auger tube scratch free. Includes 4 of each 6", 8", 10", 13", and 16" size cradles.



## Thrust Adjust Wrench Kit

B009

This wrench has been perfectly fitted to easily tighten your thrust adjuster.

(1 pcs)



## Truck Plug Extension Harness

B010

This tool adapts the agricultural 7-pin connector to your automotive 7-pin connector for your auger lights.



## Merchandise Rack

B011

This rack is highly versatile and displays parts ranging from small to large. Well-fitted with parts kit # A485. Built durable and powder coat finished to prevent rust. Comes with parts rack and red bins.

\*Parts sold separately

\*Available in yellow, silver, or red



## Tube Repair Kit

B012

This tool makes it easy to fix any dents on an auger tube. This kit is equipped to fix tube sizes of 6", 7", 8", 10", and 13". With the extension arms, you can reach the dent wherever it is on the tube.

\*Only available in yellow



## Hydraulic Pressure Gauge

B013

Use this gauge to test the pressure your tractor is putting through the hydraulic system.



## Dust Cap Driver Tool

B014

This tool is perfectly made to install the dust cap on all open discharge spouts. Applicable for all MKX<sup>2</sup>/X<sup>2</sup>/HX<sup>2</sup> augers.



## Thrust Adjust Socket

B015

This socket is the perfect size to tighten the thrust adjust nut. Applicable for all MKX<sup>2</sup>/X<sup>2</sup>/HX<sup>2</sup> augers.



Part Number	Description	Weight (lbs)	Price
<b>AUGER TOOLS</b>			
05-B001	16" Reducer/Reverser Lifter Kit	20	\$99.00
05-B002	13" Reducer/Reverser Lifter Kit	15	\$78.00
05-B003	Gooseneck Hitch Kit	252	\$683.00
05-B004	5th Wheel Hitch Kit	317	\$748.00
05-B005	Boot Lifter Kit	40	\$259.00
05-B006	Reducer/Reverser Puller Kit	43	\$431.00
05-B007	Sawhorse Kit	75	\$290.00
05-B008	Tube Cradle Kit	70	\$681.00
05-B009	Thrust Adjust Wrench Kit	10	\$60.00
05-B010	Truck Plug Extension Harness	2	\$183.00
05-B011SR	Merchandise Rack, Silver	340	\$1,204.00
05-B011YL	Merchandise Rack, Yellow	340	\$1,204.00
05-B011RD	Merchandise Rack, Red	340	\$1,204.00
05-B012	Tube Repair Kit	171	\$1,012.00
05-B013	Hydraulic Pressure Gauge	3	\$292.00
05-B014	Dust Cap Driver Tool	6	\$87.00
05-B015	Thrust Adjust Socket	3	\$64.00
05-B016	HX2 13" Clevis	12	\$187.00

# UTILITY AUGERS

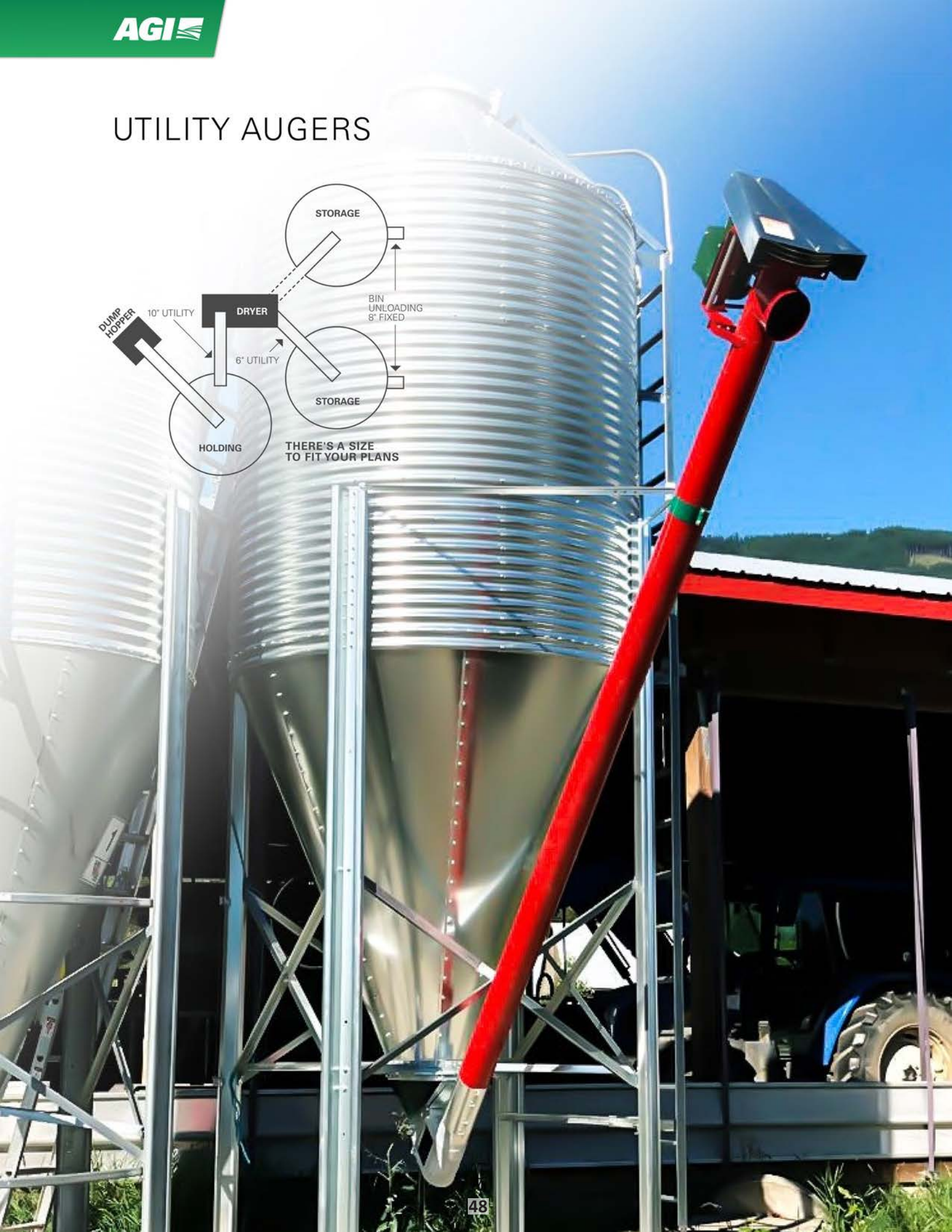
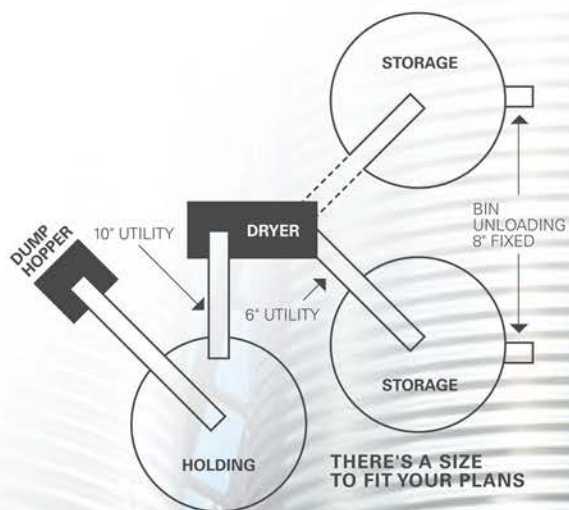



# AGI Utility Augers

- For permanent or semi-permanent auger installations
- Utility augers in 4", 6", 8", 10" and 13" diameters in various lengths
- Can be used at grain bins or bulk tanks
- Electric motor, pulley, and switches not supplied

## 4"

**11' BASIC AUGER  
5' & 10' EXTENSION**



Portable 4" auger, adjustable motor mount, shielded single "A" belt and pulley, and pre-lubricated top end bearing.

## 6" | 8" | 10"

**16' BASIC AUGER  
5', 10' or 15' EXTENSION**



Upper drive has heavy-duty flange ball bearing and adjustable motor mount with double "B" belts and pulley (triple belts on 13" models).

## 13"

**21' BASIC AUGER  
5', 10' or 15' EXTENSION**



Optional bolt-on tube clamps for attaching support bracing.



Handy swivel mount bracket for quick mounting to truck box, wagon or feed bin.



Optional bolt-on flight support bushing with grease fitting (standard on 13" models).



Optional handy steel hopper with flight support bearing. Also available with hinged lid for 6" to 10" models.



Shielded intake assembly bolts to basic drive section or extension, shown with optional adjustable feed control.

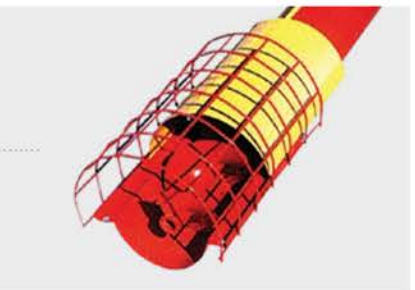

**OTHER OPTIONS** Flex Spout | Poly Hopper | Triple Groove Pulley (comes with 3-belts for long 10" augers)

## SPECIFICATIONS

	4"	6"	8"	10"	13"
RECOMMENDED PULLEY SIZE FOR 1,750 RPM MOTORS	1A 2' – 2 ¼"	2B 3½" – 4"	2B 3¼" – 3½"	2B 3¼" – 3½"	3B 3¼" – 3½"
FLIGHT SPEED	440" – 490"	480" – 550"	445" – 480"	380" – 410"	355" – 380"
AUGER PULLEY SUPPLIED	1A 8"	2B 12.7"	2B 12.7"	2B 15"	3B 16"
BELT(S) SUPPLIED	1 – A33	2 – B48	2 – B 51	2 – B 62	3 – B 67
EXTENSIONS AVAILABLE	5', 10'	5', 10', 15'	5', 10', 15'	5', 10', 15'	5', 10', 20'
TUBE GAUGE	16 GA	16 GA	14 GA	12 GA	12 GA
FLIGHT GAUGE	13 GA	12 GA	10 GA	7 GA	¼"

Note: For intermittent feed, a slightly smaller pulley will allow easier startup under load.

## HORSEPOWER REQUIREMENTS

	4"	6"	8"	10"	13"
11'	¾	—	—	—	—
16' – 21'	¾ – 1	1½ – 2	3	3 – 5	10
26' – 31'	1 – 1½	3	5	5 – 7½	15
36' – 41'	1½ – 2	3 – 5	5 – 7½	7½ – 10	20
46' – 51'	2 – 3	5	7½ – 10	10 – 15	—
56' – 61'	—	7½	10	15 – 20	—

\*Requirements above are for dry grain. High moisture grain will require additional horsepower.

**DISCLAIMER:** These augers were proudly designed to handle dry, free-flowing grains up to a maximum density of 65 lb/bu (52 lb/cf). Any usage of this auger outside of this is not authorized by AGI

Part numbers are set up as Hutchinson part numbers. To order Mayrath, change the last "H" of the part number to an "M".

Part Number	Description	Weight (lbs)	Price
<b>4" UTILITY AUGER</b>			
02-UB0411H	4" X 11' Upper Basic Section	66	\$618.00
02-UX0405	4" X 5' Extension Tube and Flighting	24	\$251.00
02-UX0410	4" X 10' Extension Tube and Flighting	46	\$387.00
05-A145	Adjustable Feed Control	4	\$79.00
05-A146	Swivel Mount Bracket	2	\$75.00
05-A152	4" Metal Intake Hopper	10	\$176.00
05-A210	4" Poly Hopper	8	\$144.00

<b>6" - 8" - 10" HEAVY-DUTY UTILITY AUGER</b>			
02-UB0616H	6" X 16' Upper Basic Section	164	\$1,262.00
02-UX0605	6" X 5' Extension Tube and Flighting	43	\$368.00
02-UX0610	6" X 10' Extension Tube and Flighting	74	\$575.00
02-UX0615	6" X 15' Extension Tube and Flighting	109	\$775.00
02-UB0816H	8" X 16' Upper Basic Section	228	\$1,560.00
02-UB0816TH	8" X 16' Upper Basic Section with Triple Grooved Pulley	228	\$1,657.00
02-UX0805	8" X 5' Extension Tube and Flighting	67	\$482.00
02-UX0810	8" X 10' Extension Tube and Flighting	116	\$767.00
02-UX0815	8" X 15' Extension Tube and Flighting	172	\$1,030.00
02-UB1016H	10" X 16' Upper Basic Section	304	\$2,215.00
02-UB1016TH	10" X 16' Upper Basic Section with Triple Grooved Pulley	304	\$2,304.00
02-UX1005	10" X 5' Extension Tube and Flighting	106	\$664.00
02-UX1010	10" X 10' Extension Tube and Flighting	194	\$1,070.00
02-UX1015	10" X 15' Extension Tube and Flighting	281	\$1,466.00

<b>13" HEAVY-DUTY UTILITY AUGER</b>			
02-UB1321H	13" X 21' Upper Basic Section	649	\$4,953.00
02-UX1305	13" X 5' Extension Tube and Flighting	160	\$1,185.00
02-UX1310	13" X 10' Extension Tube and Flighting	285	\$1,963.00
02-UX1320	13" X 20' Extension Tube and Flighting	539	\$3,357.00
05-A188	13" Hopper Kit, Bolts to Shielded Intake	41	\$408.00
05-A198	13" Tube Clamp	17	\$222.00

<b>UTILITY AUGER OPTIONS</b>			
05-A124	6" Intake Flight Support Kit	2	\$110.00
05-A126	8" Intake Flight Support Kit	4	\$128.00
05-A127	10" Intake Flight Support Kit	5	\$137.00
05-A128	6" Intake Hopper	17	\$212.00
05-A130	8" Intake Hopper	21	\$258.00
05-A131	10" Intake Hopper	33	\$295.00
05-A132	6" Truss Kit	49	\$360.00
05-A134	8" Truss Kit	56	\$382.00
05-A135	10" Truss Kit	66	\$437.00
05-A136	30' Cable Kit, 4 Lengths, 5/16" Diameter	20	\$285.00
05-A137	40' Cable Kit, 4 Lengths, 5/16" Diameter	27	\$371.00
05-A138	6" Tube Clamp	5	\$113.00
05-A140	8" Tube Clamp	8	\$124.00
05-A141	10" Tube Clamp	10	\$131.00
05-A153	6" Feed Control Kit	10	\$110.00
05-A155	8" Feed Control Kit	11	\$128.00
05-A156	10" Feed Control Kit	15	\$139.00
05-A257	6" bolt on hopper Lid Kit	6	\$54.00
05-A258	8" bolt on hopper Lid Kit	8	\$62.00
05-A259	10" bolt on hopper Lid Kit	11	\$63.00

Part Number	Description	Weight (lbs)	Price
<b>OPTIONAL EQUIPMENT</b>			
05-A103	Standard Hopper	17	\$221.00
05-A104	Big Daddy Hopper	31	\$417.00
05-A114	WRX Swivel Arc Kit	72	\$629.00
05-A119	Replacement Straps for Standard Hopper	1	\$18.00
05-A120	Replacement Straps for Big Daddy Hopper	1	\$23.00
05-A147	8" Corn Screen	20	\$622.00
05-A148	10" Corn Screen	27	\$688.00
05-A164	Poly Bucket Flex Spout, 36" - 5 Section, Fits 8/10" Augers	14	\$238.00
05-A175	Poly Bucket Spout, 49" - 5 Section, Fits 13" Augers	21	\$426.00
05-A185	13" Corn Screen	33	\$1,007.00
05-A192	Reflector Kit , 26-51"		\$76.00
05-A193	Reflector Kit, 61-81"		\$76.00
05-A194	Reflector Kit, 91-114	1	\$76.00
05-A210	4" Poly Hopper	8	\$144.00
05-A223	10" Poly V-Hopper	31	\$405.00
05-A280	16" Poly Bucket Spout	34	\$611.00
05-A282	No Snag Spout, 3 Section, Fits 10" Augers	8	\$310.00
05-A283	No Snag Spout, 3 Section, Fits 13" Augers	19	\$498.00
05-A284	No Snag Spout, 3 Section, Fits 16" Augers	26	\$641.00
05-A497	SP Motor Bracket Replacement Kit	4	\$89.00

### HYDRAULIC TRANSFER AUGERS

**Comes with variable speed control valve, 3' x 4' x 10-3/4" high hopper, wheel kit, and drive kit. 10" double drive transfer auger features 2 orbit hydraulic motors providing smoother, faster operation. Double drive eliminates the u-joint.**

05-HTA08H	8" Hydraulic Single Drive Transfer Auger	237	\$4,228.00
05-HTA10H	10" Hydraulic Double Drive Transfer Auger	325	\$5,225.00

### GAS/ELECTRIC TRANSFER AUGERS

**Gas Drive - Gearbox (1.5:1 Reduction with 13" Gearbox Pulley). Motor and Motor Pulley NOT INCLUDED.**

05-HTA08G	8" Gas Drive Transfer Auger	300	\$4,830.00
05-HTA10G	10" Gas Drive Transfer Auger	355	\$5,831.00
05-HTA08E	8" Electric Drive Transfer Auger	275	\$3,623.00
05-HTA10E	10" Electric Drive Transfer Auger	335	\$4,026.00

### TRANSFER HOPPERS (DRIVES & OPTIONS)

**INCLINED HOPPER (6 FOOT TUBE SECTION):** Shipped with pivot wheels, rubber hopper extension, and safety shields. LESS drive, LESS wheel kit. Use with HYDRAULIC or ELECTRIC drive, with optional WHEEL KIT for use independent of auger.

05-S08-6	8" Inclined Hopper - 6 Foot Section	232	\$2,210.00
05-S10-6	10" Inclined Hopper - 6 Foot Section	279	\$2,534.00

**INCLINED HOPPER (9 FOOT TUBE SECTION):** Shipped with pivot wheels, rubber hopper extension, and safety shields. LESS drive, LESS wheel kit. Use with HYDRAULIC or ELECTRIC drive, with optional WHEEL KIT for use independent of auger.

05-S08-9	8" Inclined Hopper - 9 Foot Section	264	\$2,354.00
05-S10-9	10" Inclined Hopper - 9 Foot Section	333	\$2,785.00
05-S13-10	13" Inclined Hopper - 10 Foot Section	495	\$4,534.00

**LOW-PROFILE TRANSFER HOPPER:** Shipped with four wheels, rubber hopper extension, and safety shields. LESS drive, LESS wheel kit. Use with HYDRAULIC or ELECTRIC drive (10" only).

05-S10-6LP	10" Low-Profile Transfer Hopper - 6 Foot Section	475	\$4,001.00
05-S10-9LP	10" Low-Profile Transfer Hopper - 9 Foot Section	529	\$4,268.00
05-S13-10LP	13" Low-Profile Transfer Hopper - 10 Foot Section	639	\$5,711.00

**HYDRAULIC DRIVE (FITS 8" AND 10" HOPPERS):** Shipped with hydraulic motor, mounting bracket, and drive connector. LESS hose and hose connectors.

05-H08-2	8" Hydraulic Drive	42	\$2,425.00
05-H10-2	10" Hydraulic Drive	47	\$2,460.00

Part Number	Description	Weight (lbs)	Price
<b>ELECTRIC DRIVE (FITS ALL STYLE HOPPERS):</b> Shipped with adjustable motor mount, large double pulley (8" and 10") or triple pulley (13"), belts, and shields. LESS motor and motor pulley.			
05-H08-3	8" Electric Drive	37	\$450.00
05-H10-3	10" Electric Drive	43	\$518.00
05-H13-3	13" Electric Drive	70	\$940.00
<b>WHEEL KIT (FITS ALL STYLE HOPPERS):</b> Shipped with 4.00 x 8 wheels/tires and adjustable carriage. Allows use of hoppers independent of auger when equipped with HYDRAULIC OR ELECTRIC drive.			
05-H08-4	8" Wheel Kit	48	\$626.00
05-H10-4	10" Wheel Kit	50	\$632.00
05-H13-4	13" Wheel Kit	72	\$926.00
<b>HOPPER TARPS (SHIPPED WITH HARDWARE INCLUDED)</b>			
05-A160	S08/S10 & MK80/100 Standard Hopper Tarp	6	\$338.00
05-A167	S13 & MK130 Standard Hopper Tarp	7	\$408.00
05-A184	MK100/MKX130 Low-Profile Hopper Tarp	9	\$423.00
05-A285	WRX/STX <sup>2</sup> 8/10 Intake Hopper Tarp	6	\$296.00
05-A286	WRX13 Intake Hopper Tarp	7	\$329.00
<b>DRILL FILL</b>			
03-DF614	6" x 15 1/2' Drill Fill	215	\$3,500.00
03-DF614B	6" x 15 1/2' Drill Fill with Bristle Flighting	220	\$4,229.00
05-A142	2 Section Spout	14	\$382.00
05-A143	3 Section Spout	17	\$523.00